

4

3

2

1

THIS DRAWING IS UNPUBLISHED. RELEASED FOR PUBLICATION, 19 .  
 © COPYRIGHT 19 BY AMP INCORPORATED. ALL RIGHTS RESERVED.

| LOC | DIST | REVISIONS   |                          |           |       |
|-----|------|-------------|--------------------------|-----------|-------|
| P   | LTR  | DESCRIPTION | DATE                     | DWN       | APVD  |
| CM  | 53   | 0           | RELEASED PER PR CM 99-53 | 26-AUG-99 | KW JS |

1. HOUSING HAS A UL ELECTRICAL TEMPERATURE INDEX OF 150° C.
2. TO BE USED WITH APPROPRIATE .140 MATE-N-LOK PINS.

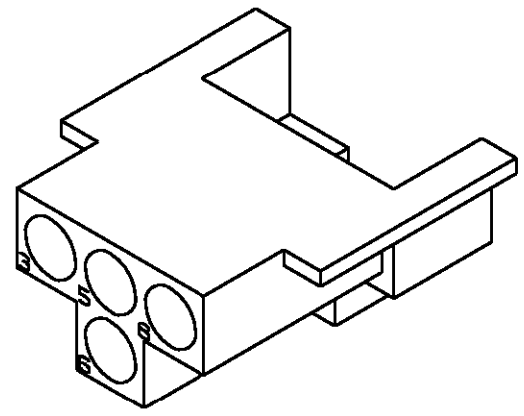
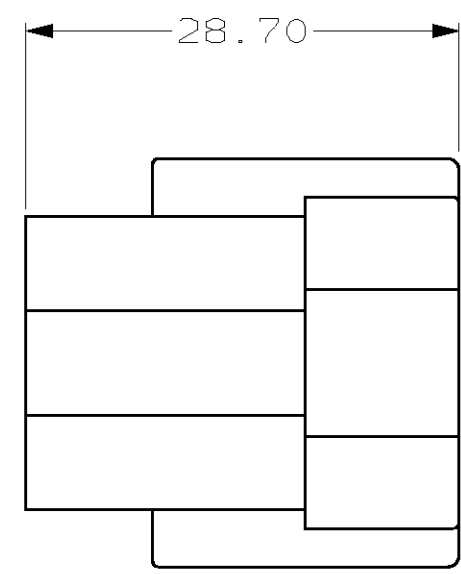
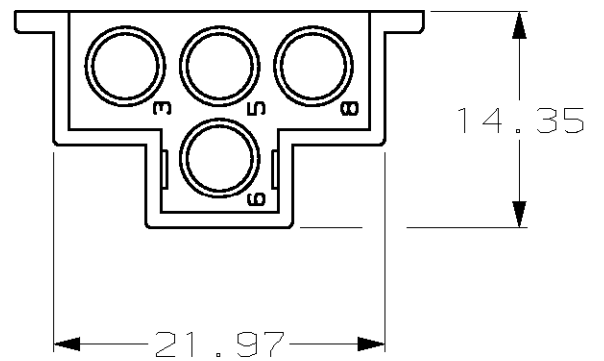
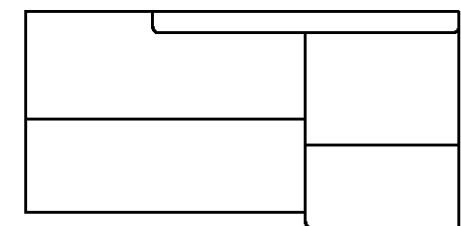
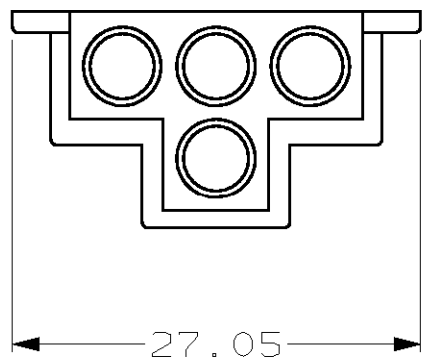

3-DIMENSIONAL MODEL  
NTS

794700-1  
PART NUMBER

|                  |       |
|------------------|-------|
| 28.70            | 1.130 |
| 27.05            | 1.065 |
| 21.97            | .865  |
| 14.35            | .565  |
| 3.56             | .140  |
| 0.13             | .005  |
| MM               | IN    |
| CONVERSION TABLE |       |

**METRIC**

|   |        |                                   |  |       |    |       |       |       |    |       |    |        |        |                   |            |
|---|--------|-----------------------------------|--|-------|----|-------|-------|-------|----|-------|----|--------|--------|-------------------|------------|
| THIS DRAWING IS A CONTROLLED DOCUMENT.  |        | DWN<br>K. WHITAKER<br>26-AUG-1999 | <b>AMP</b> AMP Incorporated<br>Harrisburg, PA 17105-3608 |       |    |       |       |       |    |       |    |        |        |                   |            |
| DIMENSIONS:<br>mm   |        | CHK<br>J. SCHLUNZ<br>26-AUG-1999  |  |       |    |       |       |       |    |       |    |        |        |                   |            |
| TOLERANCES UNLESS OTHERWISE SPECIFIED:  |        | APVD<br>J. SCHLUNZ<br>26-AUG-1999 | NAME<br>CAP, 4 CIRCUIT,<br>.140 MATE-N-LOK™              |       |    |       |       |       |    |       |    |        |        |                   |            |
| <table border="0"> <tr><td>0 PLC</td><td>±-</td></tr> <tr><td>1 PLC</td><td>±-</td></tr> <tr><td>2 PLC</td><td>±0.13</td></tr> <tr><td>3 PLC</td><td>±-</td></tr> <tr><td>4 PLC</td><td>±-</td></tr> <tr><td>ANGLES</td><td>±0°30'</td></tr> </table> |        | 0 PLC                             | ±-   | 1 PLC | ±- | 2 PLC | ±0.13 | 3 PLC | ±- | 4 PLC | ±- | ANGLES | ±0°30' | PRODUCT SPEC<br>- | SIZE<br>A3 |
| 0 PLC   | ±-     |                                   |  |       |    |       |       |       |    |       |    |        |        |                   |            |
| 1 PLC   | ±-     |                                   |  |       |    |       |       |       |    |       |    |        |        |                   |            |
| 2 PLC   | ±0.13  |                                   |  |       |    |       |       |       |    |       |    |        |        |                   |            |
| 3 PLC   | ±-     |                                   |  |       |    |       |       |       |    |       |    |        |        |                   |            |
| 4 PLC   | ±-     |                                   |  |       |    |       |       |       |    |       |    |        |        |                   |            |
| ANGLES  | ±0°30' |                                   |  |       |    |       |       |       |    |       |    |        |        |                   |            |
| MATERIAL<br>NYLON,<br>UL 94V-2, BLACK   |        | APPLICATION SPEC<br>-             | CAGE CODE<br>00779                                       |       |    |       |       |       |    |       |    |        |        |                   |            |
| FINISH<br>-   |        | WEIGHT<br>-                       | DRAWING NO<br>C- 794700                                  |       |    |       |       |       |    |       |    |        |        |                   |            |
| CUSTOMER DRAWING  |        |                                   | RESTRICTED TO<br>-                                       |       |    |       |       |       |    |       |    |        |        |                   |            |
| SCALE<br>2:1  |        |                                   | SHEET<br>1 OF 1  |       |    |       |       |       |    |       |    |        |        |                   |            |
| REV<br>0  |        |                                   |  |       |    |       |       |       |    |       |    |        |        |                   |            |