

4

3

2

1

THIS DRAWING IS UNPUBLISHED. RELEASED FOR PUBLICATION  
© COPYRIGHT ALL RIGHTS RESERVED.

LOC	DIST	REVISIONS			
P	LTR	DESCRIPTION	DATE	DWN	APVD
	A1	ECR-15-004848	27MAR2015	GK	HMR

# REPLACED BY OCEAN STYLE APPLICATOR PART NUMBER 2150524-2

FOR REPLACEMENT PARTS FOR APPLICATOR 1855180 REFER TO ADDITIONAL PAGE(S). SPARE PARTS KIT (IF LISTED) WILL REMAIN AVAILABLE.

THE REPLACEMENT OCEAN STYLE APPLICATOR HAS THE SAME TERMINATOR/PRESS INTERFACE AS APPLICATOR 1855180

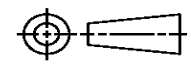
THIS DRAWING IS A CONTROLLED DOCUMENT.		DWN	GOPALAKRISHNA HV		
DIMENSIONS:		CHK	RAGHAVENDRA		
		APVD	RAGHAVENDRA		
TOLERANCES UNLESS OTHERWISE SPECIFIED:		PRODUCT SPEC	NAME		
0 PLC	±	APPLICATION SPEC	END FEED HDM APPLICATOR		
1 PLC	±		SIZE	CAGE CODE	DRAWING NO
2 PLC	±		A3		©- 1855180
3 PLC	±				RESTRICTED TO
4 PLC	±				
ANGLES	±	WEIGHT			
MATERIAL	FINISH	CUSTOMER DRAWING	SCALE	SHEET 1 OF 2	REV A1



PART NUMBER	REV	FIRST USED	POWER UNIT	FEED TYPE
1855180-1	A	122500-1	LEADMAKER & BENCH MODEL G	AIR FEED
1855180-2	A	565435-5	BENCH MODEL K	AIR FEED
7-1855180-7	A	-	SPARE PARTS	-

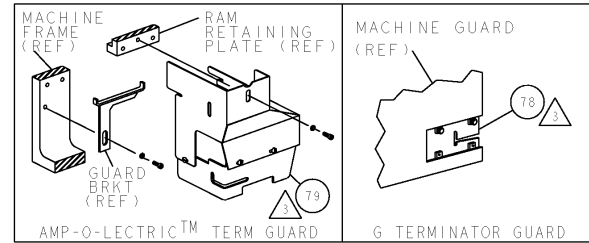

TERMINAL NAME: RING TONGUE			
42946	-	AMP TERMINAL - AMP CRIMP SPECS	
42947	-		
61288	-	CRIMP HEIGHT	WIRE SIZE REF SETTING*
61289	-	.159±.002[4.04±0.05mm]	8 AWG 4 5
61290	-	.139±.002[3.53±0.05mm]	10 AWG B 3 6
640012	-	.127±.002[3.23±0.05mm]	12 AWG D 8 6
640014	-		
		CRIMP	SIZE TYPE RANGE
		WIRE	.210 [5.33mm] F 12-8 AWG 4
		INSUL	.300 [7.62mm] O .191 - .220
WIRE STRIP LENGTH SEE APPL SPEC	TERM APPL SPEC 114-2084	FEED 1.370	APPL INSTRUCTIONS 408-8039 SET UP GAUGE 458638-1

LOC	QTY	REV	DESCRIPTION	DATE	BY	APPV
A	66		SEE ECO-07-005361	07MAR2007	LJL	MC

- △ RECOMMENDED SPARE PARTS
- △ GREASE LIGHTLY
- △ GUARD MUST BE IN PLACE WHEN OPERATING APPLICATOR IN A BENCH MACHINE.
- △ 8 AWG WIRE SUBJECT TO ENGINEERING APPROVAL.
- △ ITEMS 38 & 39 REQUIRED TO CRIMP 8 AWG WIRE.
- △ ITEMS 178 & 179 REQUIRED TO CRIMP 10 & 12 AWG WIRE.

**\*WARNING:**

ON INSTALLATION, SET WIRE DISC TO LARGEST WIRE SIZE SETTING. USE OF SETTINGS BELOW MIN REQUIRED CRIMP HEIGHT SETTING WILL CAUSE DAMAGE TO CRIMP TOOLING.

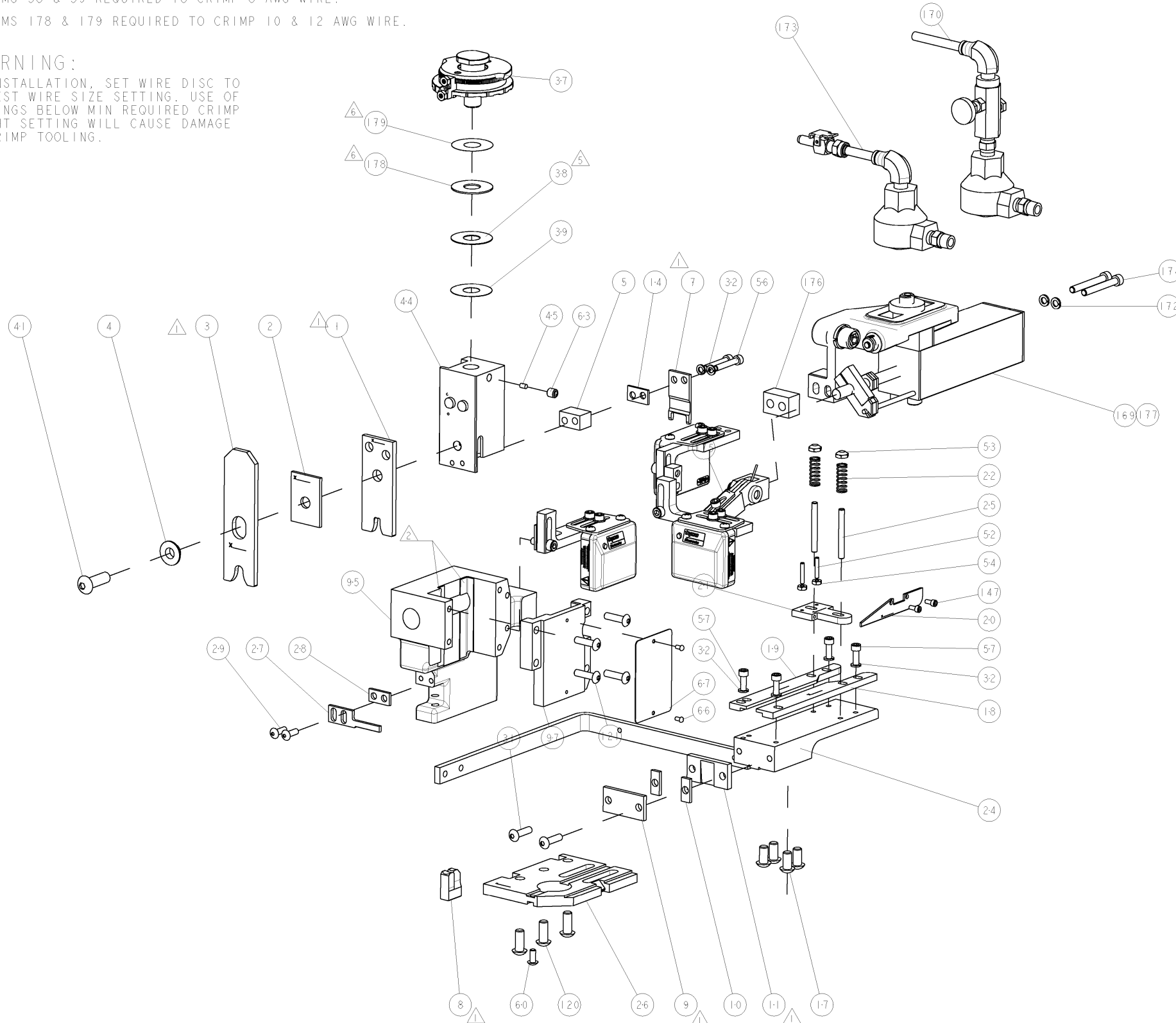

△	-	1	1	-	469367-3	SHIM	179
△	-	1	1	-	469367-7	SHIM	178
△	-	1	-	-	1-460277-5	AIR FEED ASSY	177
-	-	1	1	-	461690-2	SPACER, AIR FEED	176
-	-	1	1	-	460680-1	FEED FINGER ASSEMBLY	175
-	-	2	2	-	4-21000-1	SCR, SKT HD CAP 10-32 X 1.500	174
-	-	-	1	-	692655-7	AIR FEED VALVE ASSEMBLY	173
-	-	2	2	-	21024-5	WASHER, SPRG LOCK, REG NO 10	172
-	-	1	-	-	692655-5	AIR FEED VALVE ASSEMBLY	170
-	-	-	1	-	1-460277-9	AIR FEED ASSY	169
-	-	2	2	-	1-21000-3	SCR, SKT HD CAP 4-40 X .250	147
-	-	4	4	-	2-21002-9	SCR, BTN SKT HD CAP 10-32 X .750	121
-	-	3	3	-	2-22733-8	SCR, BHSC, SELF-LOCKING, 1/4-20 X .625	120
-	-	1	1	-	454220-1	CAP, RAM	97
-	-	1	1	-	453736-1	HOUSING, APPLICATOR	95
△	-	REF	-	-	455745-1	GUARD WINDOW	79
△	-	REF	-	-	679532-1	INSERT, GUARD	78
-	-	1	1	-	217238-1	GENERAL INSTRUCTION PKG	72
-	-	1	1	-	4088039	EF APPL INST 408-8039	71
-	-	1	1	-	461264-5	PLATE, IDENTIFICATION	67
-	-	2	2	-	21017-2	SCREW, DRIVE	66
-	-	1	1	-	21009-2	SCR, SET, SELF LOCKING 1/4-20 X .250	63
-	-	1	1	-	22733-8	SCR, BHSC, SELF-LOCKING, 8-32 X .375	60
-	-	4	4	-	2-21000-7	SCR, SKT HD CAP 8-32 X .500	57
-	-	2	2	-	3-21000-1	SCR, SKT HD CAP 8-32 X 1.000	56
-	-	2	2	-	21018-4	NUT, HEX, REG 4-40	54
-	-	2	2	-	21022-2	NUT, LOCK, HEX, TORQUE, 8-32	53
-	-	2	2	-	2-21006-6	SCR, SET, CUP POINT 4-40 X .625	52
-	-	1	1	-	690191-1	PLUG, NYLON	45
-	-	1	1	-	1-455674-3	RAM	44
-	-	1	1	-	7-21002-9	SCR, BTN SKT HD CAP 5/16-24 X 1.00	41
-	-	1	1	-	690125-1	SHIM SUB-ASSY	39
△	-	1	1	-	469367-9	SHIM	38
-	-	1	1	-	879103-2	FINE ADJUST HEAD SUBASSY	37
-	-	6	6	-	21024-4	WASHER, SPRG LOCK, REG NO 8	32
-	-	2	2	-	2-21002-9	SCR, BTN SKT HD CAP 10-32 X .750	31
-	-	2	2	-	2-21002-2	SCR, BTN SKT HD CAP 8-32 X .500	29
-	-	1	1	-	1-690451-1	SPACER, STRIPPER	28
-	-	1	1	-	690455-8	STRIPPER, FRONT CASTING	27
-	-	1	1	-	455676-2	PLATE, BASE	26
-	-	2	2	-	22354-8	STUD, THREADED	25
-	-	1	1	-	455678-1	PLATE, STRIP GUIDE	24
-	-	2	2	-	2-22281-6	SPRING, COMPRESSION	22
-	-	1	1	-	464451-1	ARM, STOCK DRAG	21
-	-	1	1	-	464452-6	DRAG, STOCK	20
-	-	1	1	-	4-458030-6	STRIP GUIDE, REAR	19
-	-	1	1	-	4-458031-6	STRIP GUIDE, FRONT	18
-	-	4	4	-	3-21002-3	SCR, BTN SKT HD CAP 1/4-20 X .500	17
-	-	1	1	-	6-240641-4	SPACER	14
△	-	1	1	-	240644-1	PLATE, REAR SHEAR	11
△	-	2	2	-	1-240645-1	SPACER, SHEAR PLATE	10
△	-	1	1	-	240642-2	PLATE, FRONT SHEAR	9
△	1	1	1	-	8-683452-7	ANVIL, COMBINATION	8
△	-	1	1	-	8-240651-2	BLADE, SLUG	7
△	-	1	1	-	7-240641-3	SPACER	5
-	-	1	1	-	238009-3	BLOCK, FL CRIMPER SPACER	4
△	1	1	1	-	8-683454-0	CRIMPER, INSULATION O	3
△	-	1	1	-	2-455888-1	SPACER, CRIMPER	2
△	1	1	1	-	1-456430-0	CRIMPER, WIRE	1

INCHES	TOLERANCES UNLESS OTHERWISE SPECIFIED:	APPROVED	DATE	DESCRIPTION	ITEM NO
0 PLC ±.01	1 PLC ±.01	APPROVED	12FEB2007	END FEED HDM APPLICATOR	
1 PLC ±.01	2 PLC ±.01	APPROVED	12FEB2007		
2 PLC ±.01	3 PLC ±.01	APPROVED			
3 PLC ±.01	4 PLC ±.01	APPROVED			
4 PLC ±.01	ANGLES ±.001	APPROVED			