

( [47.45] )  
1.868  
COMPLETELY COLSED  
"B"

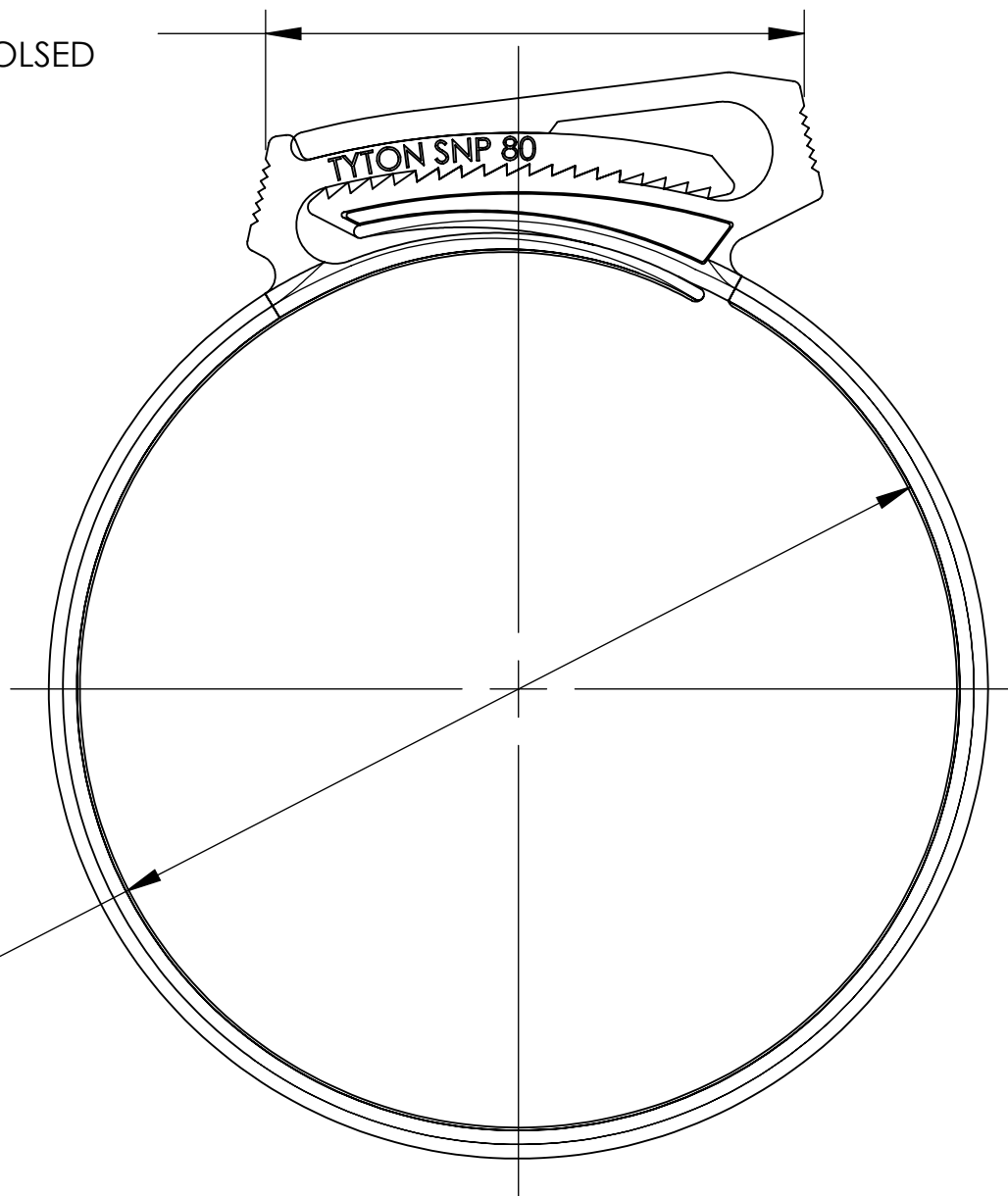

[79.40±0.51]  
Ø3.126±.020  
SEE NOTE 1  
"D"

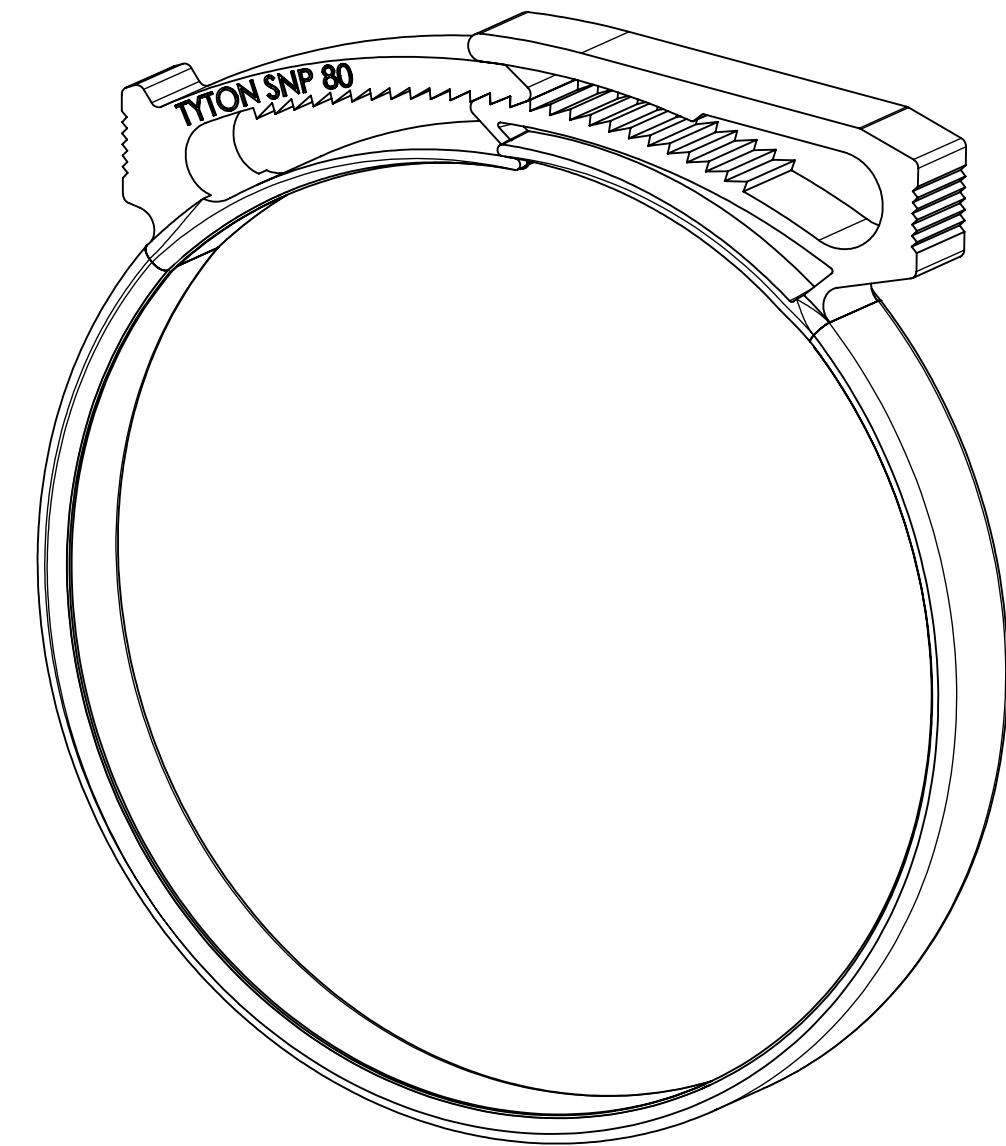
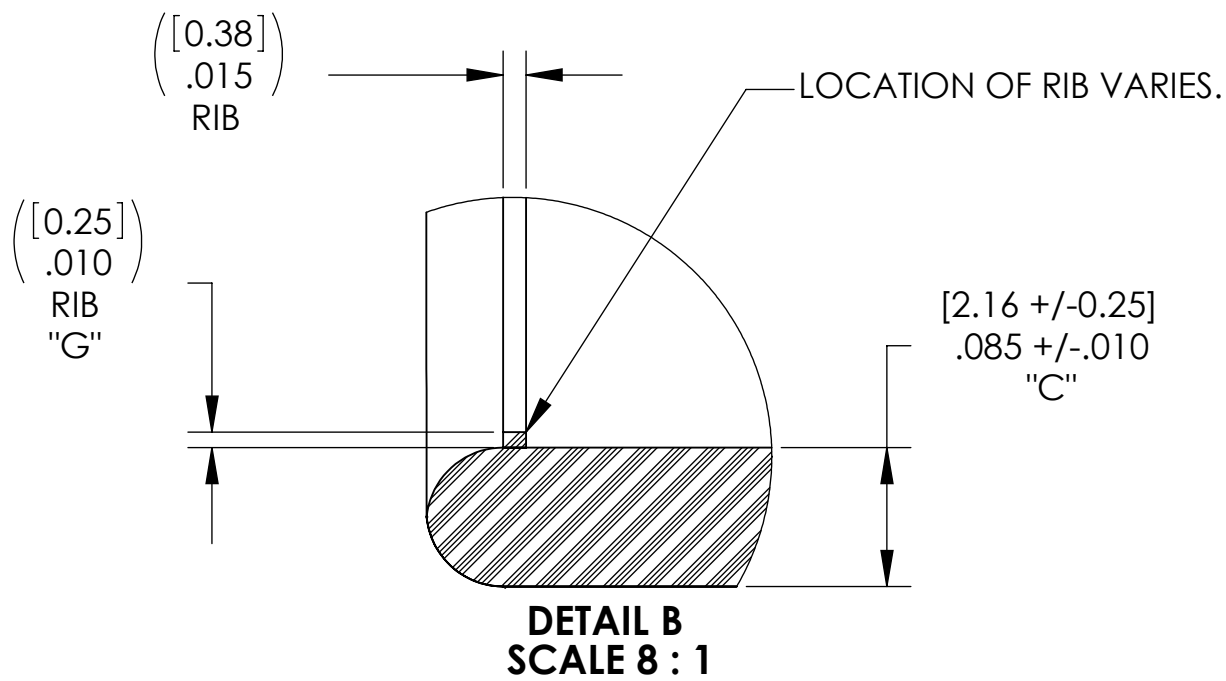

( [78.66] )  
3.097  
MAXIMUM 2 TEETH  
ENGAGED  
"A"

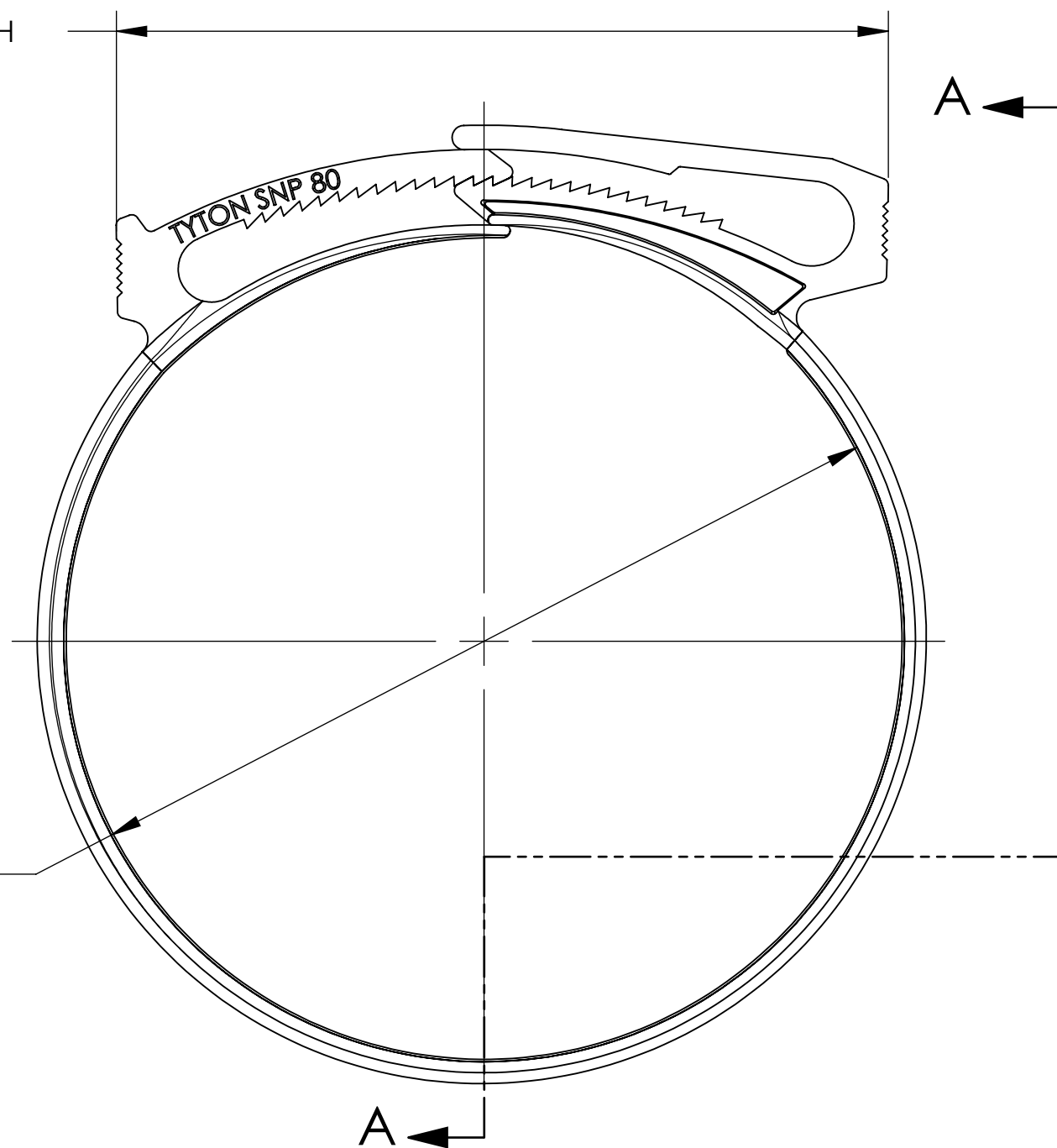

[88.32±0.51]  
Ø3.477±.020  
SEE NOTE 1  
"E"

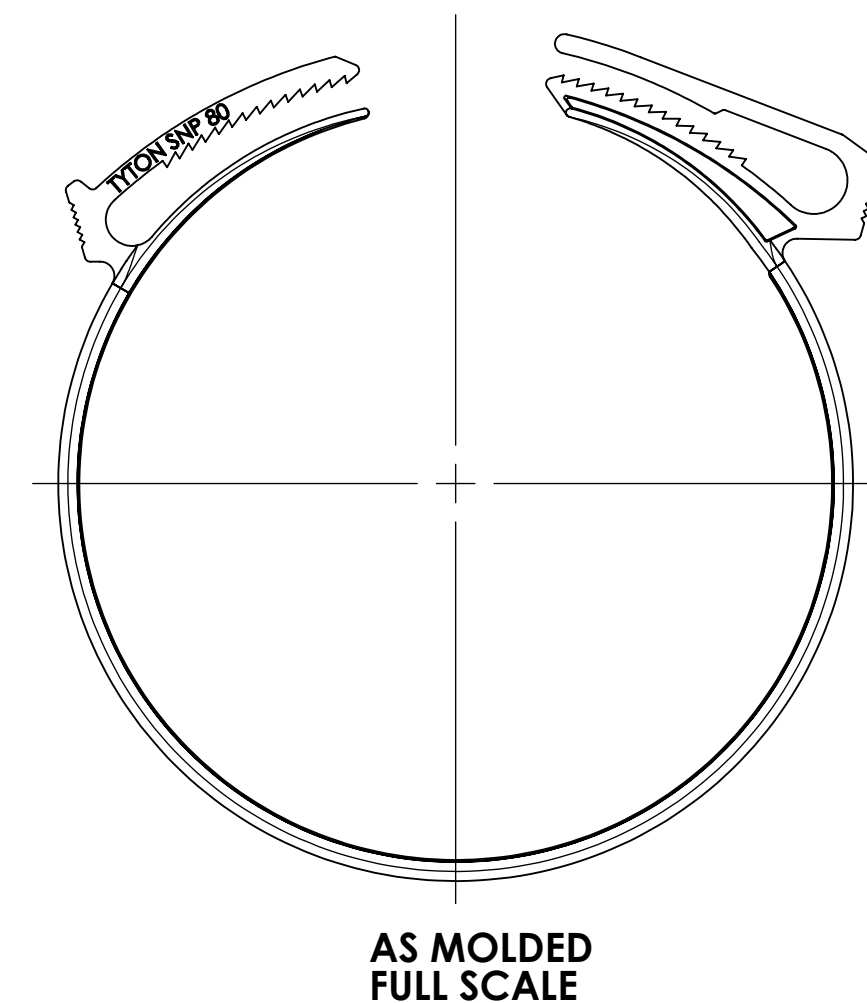
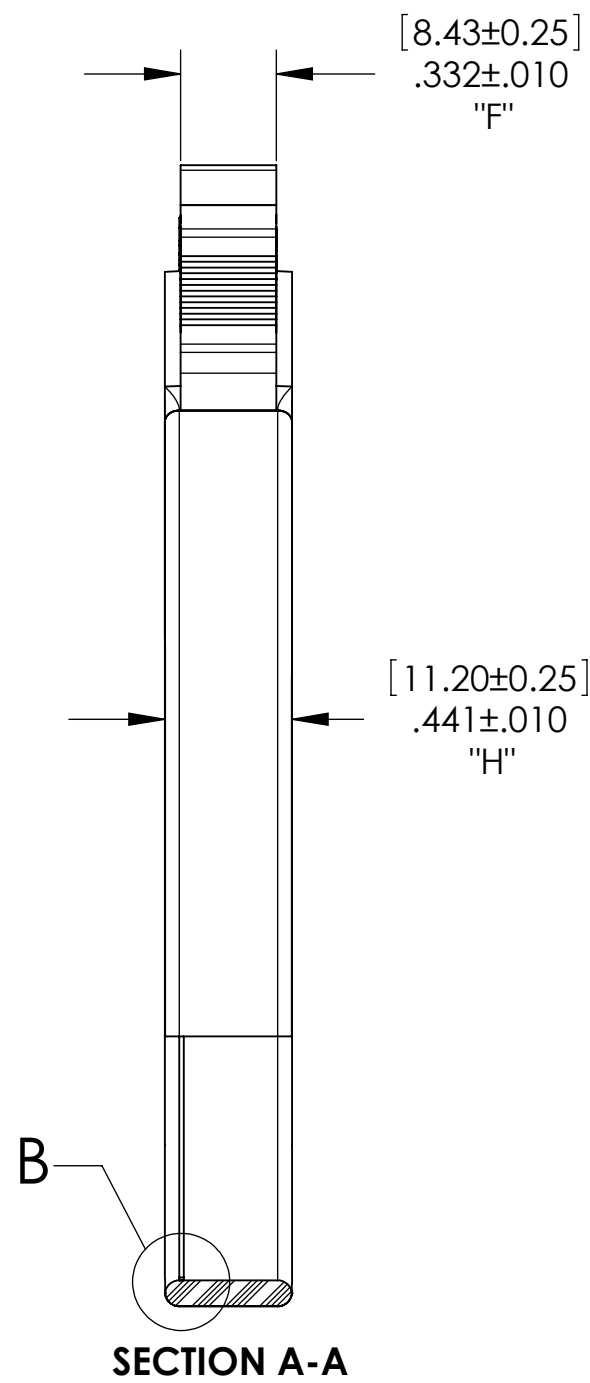

INVENTORS

**HellermannTyton.**

ALL PROPRIETARY RIGHTS IN THE SUBJECT MATTER SHOWN ON THIS DRAWING ARE EXCLUSIVE PROPERTY OF HELLERMANN TYTON

name date city, state

NOTES

- 1) INSIDE DIAMETERS ARE MEASURED IN THREE PLACES SPACED 120 DEGREES APART EXCLUDING RIB.
- 2) 28 TOTAL TEETH, 18 TEETH POSITIONS.

REVISIONS

level	01
by	K.A.C.
date	10/29/2003
ECN #	004150
part level	-

DIMENSIONS

.XXXX = [±.013]/±.0005  
.XXX = [±.13]/±.005  
.XX = [±.3]/±.01  
.X = [±.8]/±.03  
∠ = ±0.5°  
unless otherwise specified  
units [mm]/inches

PART

number	SNP80_	phase	Production
name	SNP80 HOSE CLAMP		
material	ACETAL		

DRAWING

format	C	SW 2004	scale	1.5:1
version N	CAD			
computer file name	CP2080002CST_01	previous drawing number		
drawn	K.A.C.	checked	K.A.C.	approved
date	10/29/2003	checked	10/31/03	approved
type	Customer	sheet	1 of 1	
number	CP2080002CST			