



## Operating the THERMOFOX thermal transfer printer

User manual



# User manual

## Operating the THERMOFOX thermal transfer printer

2016-11-23

---

Designation: UM EN THERMOFOX

Revision: 02

Order No.: -

This user manual is valid for:

Designation	Version	Order No.
THERMOFOX		0803984
THERMOFOX SET		0803986

## Please observe the following notes

### Explanation of symbols used and signal words



This is the safety alert symbol. It is used to alert you to potential personal injury hazards. Obey all safety measures that follow this symbol to avoid possible injury or death.

There are three different categories of personal injury that are indicated with a signal word.

**DANGER** This indicates a hazardous situation which, if not avoided, will result in death or serious injury.

**WARNING** This indicates a hazardous situation which, if not avoided, could result in death or serious injury.

**CAUTION** This indicates a hazardous situation which, if not avoided, could result in minor or moderate injury.



This symbol together with the signal word **NOTE** and the accompanying text alert the reader to a situation which may cause damage or malfunction to the device, hardware/software, or surrounding property.



This symbol and the accompanying text provide the reader with additional information or refer to detailed sources of information.

### How to contact us

#### Internet

Up-to-date information on Phoenix Contact products and our General Terms and Conditions can be found on the Internet at:

[phoenixcontact.com](http://phoenixcontact.com)

Make sure you always use the latest documentation. It can be downloaded at:

[phoenixcontact.net/products](http://phoenixcontact.net/products)

#### Subsidiaries

If there are any problems that cannot be solved using the documentation, please contact your Phoenix Contact subsidiary. Subsidiary contact information is available at:

[phoenixcontact.com](http://phoenixcontact.com)

---

**Published by**

PHOENIX CONTACT GmbH & Co. KG  
Flachsmarktstraße 8  
32825 Blomberg  
GERMANY

Should you have any suggestions or recommendations for improvement of the contents and layout of our user manual, please send your comments to:

[tecdoc@phoenixcontact.com](mailto:tecdoc@phoenixcontact.com)

**General Terms and Conditions of Use for technical documentation**

Phoenix Contact reserves the right to alter, correct, and/or improve the technical documentation and the products described in the technical documentation at its own discretion and without giving prior notice, insofar as this is reasonable for the user. The same applies to any changes that serve the purpose of technical progress.

The receipt of technical documentation (in particular user documentation) does not constitute any further duty on the part of Phoenix Contact to furnish information on modifications to products and/or technical documentation. You are responsible for verifying the suitability and intended use of the products in your specific application, in particular with regard to observing the applicable standards and regulations. All information made available in the technical data is supplied without any accompanying guarantee, whether expressly mentioned, implied or tacitly assumed.

In general, the provisions of the current General Terms and Conditions of Phoenix Contact apply exclusively, in particular as concerns any warranty liability.

This user manual, including all illustrations contained herein, is copyright protected. Any changes to the contents or the publication of extracts of this document is prohibited.

Phoenix Contact reserves the right to register its own intellectual property rights for the product identifications of Phoenix Contact products that are used here. Registration of such intellectual property rights by third parties is prohibited.

Other product identifications may be afforded legal protection, even where they may not be indicated as such.

## Table of contents

1	For your safety .....	7
	1.1 Field of application.....	7
	1.2 Safety notes.....	7
2	Starting up the printer .....	8
	2.1 Checking the scope of supply .....	8
	2.2 Overview of the device .....	9
	2.3 Connecting the power supply .....	10
	2.4 Inserting the material cartridge .....	11
	2.5 Switching on the device .....	11
3	Operating elements .....	12
	3.1 Display.....	14
	3.2 Menu .....	15
4	Creating the marking .....	23
	4.1 Creating the marking on the display.....	23
	4.2 Creating the marking on the PC.....	32
	4.3 Printing .....	33
5	Maintenance and troubleshooting .....	34
	5.1 Cleaning .....	34
	5.2 Troubleshooting.....	36
	5.3 Repairs .....	40
	5.4 Firmware update.....	40
	5.5 Disposal.....	40
6	Appendix .....	41
	6.1 Technical data .....	41
	6.2 Ordering data for accessories.....	42
	6.3 Overview of the symbols.....	43
	6.4 Approvals .....	46

# 1 For your safety

## 1.1 Field of application

The THERMOFOX is a portable thermal transfer printer for industrial use. The thermal transfer printer prints self-adhesive and non-adhesive labels and heat-shrinkable tubes for marking electrical components. The THERMOFOX uses special material cartridges that contain the material as well as the corresponding ink ribbon. Only use material cartridges that are provided for the THERMOFOX by Phoenix Contact.

## 1.2 Safety notes

### **Risk to operational reliability**

Incorrect operation or modifications to the device can endanger your safety or damage the printer. Do not repair the product yourself. If the device is defective, please contact Phoenix Contact.

### **Explosion hazard, fire hazard, and health hazard if batteries are used incorrectly**

- Only use dry batteries in a proper condition.
- Never damage the batteries (e.g., by throwing, pressing on the battery or using sharp objects). Never expose the batteries to high levels of heat (e.g., caused by fire or sunlight). Never let the batteries come in contact with moisture or salt water.
- Pay attention to the correct polarity when inserting the batteries.
- Only charge the battery in the THERMOFOX or in the designated charger (THERMOFOX/CHARGER, 0805012). Do not use any other chargers, e.g., cigarette lighter socket in the car.
- Temperature range when charging the battery: 0°C ... 45°C
- Store the battery separately in a dry and cool place.

### Damage to the device

- Do not operate the printer near high-voltage lines.
- Only operate the printer in a dry location protected from spray.
- Protect the printer and printing materials from humidity, moisture, and dirt.
- Only connect the printer to systems that have a protective extra low voltage.
- To operate the printer with connection to a mains power supply, only use the provided wide range power supply unit (THERMOFOX/ADAPTER, 0805010).

## 2 Starting up the printer

### 2.1 Checking the scope of supply

#### THERMOFOX

- Printer
- Brief instructions

#### THERMOFOX SET

- Printer
- Battery (THERMOFOX/ACCU, 0805009)
- Wide range power supply unit with four adapters for different sockets (THERMOFOX/ADAPTER, 0805010)
- USB cable
- Two material cartridges
  - Vinyl polymer, 18 mm, white (MM-EMLF (EX18)R C1 WH/BK, 0803939)
  - Polyamide, 18 mm, white (MM-EMLC (EX18)R C1 WH/BK, 0803936)
- DVD with driver and CLIP PROJECT Marking software. The DVD also contains this user manual in several languages.
- User manual

#### Unpacking

- Check the printer for transport damage.



## 2.2 Overview of the device

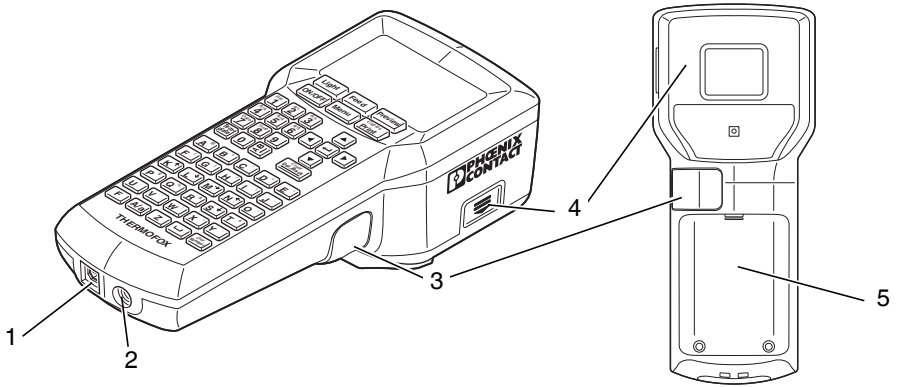

Figure 2-1 Overview

- 1 Socket for USB connection
- 2 Socket for power supply unit
- 3 Cutter for continuous media
- 4 Compartment for material cartridge
- 5 Battery compartment

## 2.3 Connecting the power supply

The THERMOFOX can be supplied with power in different ways.

- Batteries (6x AA alkaline)
- AC wide range power supply unit (THERMOFOX/ADAPTER, 0805010)
- Battery (THERMOFOX/ACCU, 0805009)

If the THERMOFOX is connected to the power supply via the power supply unit, the battery in the THERMOFOX is automatically charged. The battery can also be charged using an external charger (THERMOFOX/CHARGER, 0805012).

### Connecting the power supply unit

The THERMOFOX is designed for power grids from 100 to 240 V AC. Only connect the THERMOFOX to sockets with a ground conductor contact.

**Only use the provided wide range power supply unit (THERMOFOX/ADAPTER, 0805010).**

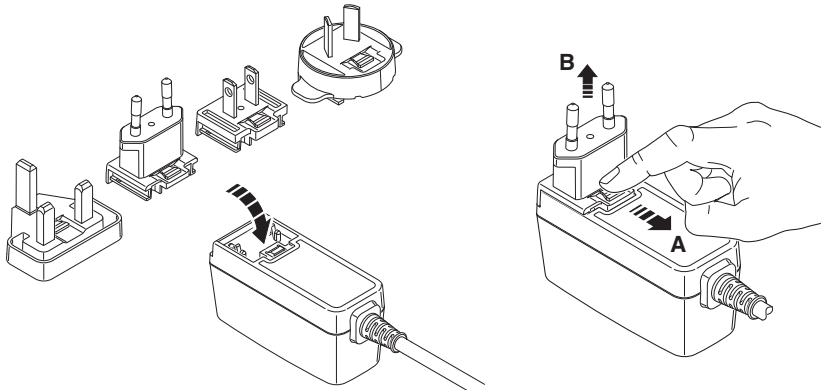

Figure 2-2 Mains connection

- Slightly tilt the relevant adapter and place it onto the front side of the power supply unit and press the adapter down. To remove the adapter, pull the slider on the base element in the direction of the cable.
- Insert the connecting cable of the power supply unit in the socket of the printer.
- Connect the power supply unit to a grounded socket with a ground conductor contact.

## 2.4 Inserting the material cartridge

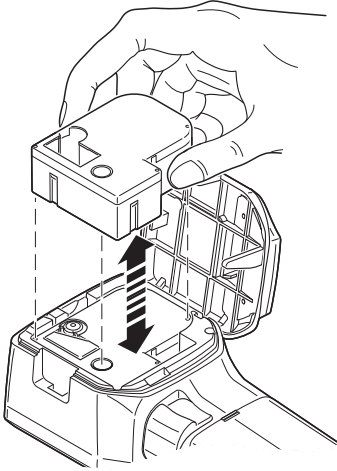

Figure 2-3 Replacing the material cartridge



- Keeping the material cartridge straight, insert it into the compartment from above so that it engages with a click.  
Make sure that the material end is in the output tray.
- To remove the material cartridge, pull it upward while keeping it straight.



**NOTE: Damage to the printer and material cartridge**

If the printer is not going to be used for a prolonged period of time, remove the material cartridge from the printer.

## 2.5 Switching on the device

- Switch on the printer using the green  key.
- Press the green  key until the display lights up.

### 3 Operating elements

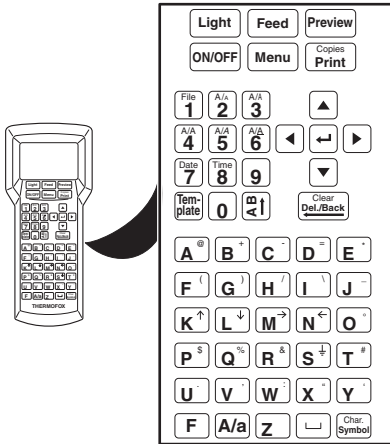









Figure 3-1 Operating elements

Operating elements		
<b>Green keys</b>		
	On/off switch	
	Function key; uses the assignment labeled green when pressing a key (e.g., @ instead of A)	
<b>Black keys</b>		
	Display lighting	–
	Material advance	–
	Preview of the print result	–
	Call menu In a values selection, the value is accepted and you are returned to the input screen	–
	Start printing	Multiple copy

## Operating elements

Operating elements		
Turquoise keys		Function key pressed
	Selection of templates	–
	Changes the text alignment (horizontal/vertical)	–
	Confirm entry, new line (up to six lines are possible)	–
	In the menu: back to the previous level On the input screen: delete previous character	On the input screen: delete entire contents
	Switches between upper case and lower case letters	–
	Space	–
	Selection of symbols	Selection of special characters, e.g., à, È, ì, Ç
Gray keys		Function key pressed
<b>Numbers</b>	Entering numbers 0 – 9	1 = file 2 = font size 3 = narrow 4 = bold 5 = italic 6 = underline 7 = date 8 = time
<b>Letters</b>	Letters A - Z	Selects the assignment labeled green
<b>Arrow keys</b>	Line change, navigating in the menu	

### 3.1 Display

The first line in the display shows the settings selected.

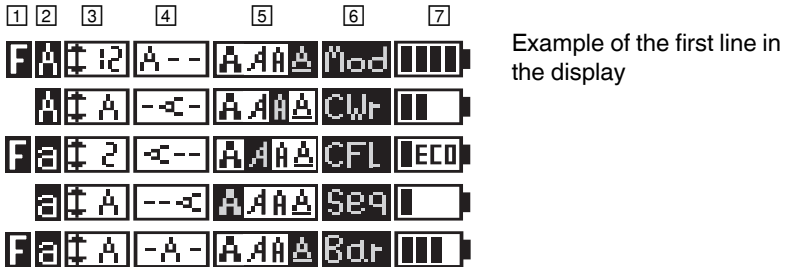

- 1 “F” indicates that the green **F** function key has been pressed. The function key is used to switch to the assignment labeled green when pressing a key (e.g., @ instead of A).
- 2 Indicates whether upper case or lower case letters are used. Can be switched using the turquoise **A/a** key.
- 3 Indicates the selected line height in mm. The “A” stands for “auto”. The line height is adjusted according to the space available.  
Can be switched using number key “2” if the function key has been activated simultaneously. To set the desired height in mm, press number key “2” several times (Auto Size, 2 mm ... 22 mm).
- 4 Text alignment  
The turquoise **A** button can be used to switch between text alignments. The text alignment switches in the following order:
 

1. horizontal – centered	4. vertical – right-aligned
2. vertical – centered	5. horizontal – left-aligned
3. horizontal – right-aligned	6. vertical – left-aligned
- 5 Text format (bold, italic, narrow, underline). Can be switched using the number keys if the function key has been activated simultaneously.  
3 = narrow, 4 = bold, 5 = italic, 6 = underline
- 6 Print layouts for specific requirements
  - Rows of labels with a fixed width (“Mod”, see Section 4.1.5)
  - Cable marking (“CW<sub>r</sub>”, see Section 4.1.6)
  - Cable flags (“CFL”, see Section 4.1.7)
  - Insert Barcode (“Bar”, see Section 4.1.3)
  - Insert Sequence (“Seq”, see Section 4.1.4)
- 7 State of power supply

## 3.2 Menu

Use the arrow keys to navigate through the menu. Press the  $\downarrow$  key to select an entry and  $\left[ \begin{smallmatrix} \text{Clear} \\ \text{Del./Back} \end{smallmatrix} \right]$  to go back.

### Changing the language

The menu is set to English by default. To change the language, proceed as follows:

- Press the black  $\left[ \text{Menu} \right]$  key.
- Select “A. Setup”. Press the  $\left[ \leftarrow \right]$  key.
- Select “1. Language”. Press the  $\left[ \leftarrow \right]$  key.
- Select a language.
- Press the  $\left[ \leftarrow \right]$  key to select an entry. Go back with  $\left[ \begin{smallmatrix} \text{Clear} \\ \text{Del./Back} \end{smallmatrix} \right]$  or  $\left[ \text{Menu} \right]$  key.

Table 3-1 Menu

Level 1	Level 2	Level 3	Level 4	Description	
<b>1. File</b>	<b>1. Save</b>			Save marking	
	<b>2. Load</b>			Load stored marking (1 to 20 files)	
	<b>3. Print</b>			Print stored marking	
	<b>4. Delete</b>			Delete stored marking	
<b>2. Font</b>	<b>1. Size</b>	<b>Auto Size</b>		Font is adjusted according to space available	
		<b>2 mm ... 22 mm</b>		Font size in mm      ABC	
	<b>2. Style</b>	<b>1. Bold</b>		Bold	<b>ABC</b>
		<b>2. Italic</b>		Italic	<i>ABC</i>
		<b>3. Narrow</b>		Narrow	ABC
		<b>4. Underline</b>		Underline	<u>ABC</u>
		<b>5. Mirror</b>		Mirrored	ƆBA

Table 3-1 Menu [...]

Level 1	Level 2	Level 3	Level 4	Description
<b>3. Symbol</b>	<b>Punctuation</b>			Punctuation marks ! " #
	<b>General symbols</b>			General symbols § © ®
	<b>Units</b>			Units \$ £ ¢
	<b>Electr. General</b>			Electrical symbols ⚡ ⚡ ⚡
	<b>Electr. Comp.</b>			Electrical components ☐
	<b>Home Electrics</b>			Home electrics ☀ 🔔
	<b>Safety Signs</b>			Safety symbols ⚠ ⚠
	<b>Superscript</b>			Superscript characters ± - +
	<b>Subscript</b>			Subscript characters ± - +
	<b>Arrows</b>			Arrows ← ↑ →
	<b>Greek Upper Case</b>			Greek upper case letters ΑΒΓΔ
	<b>Greek Lower Case</b>			Greek lower case letters αβγδ
	<b>Mathematical</b>			Mathematical symbols ± ≥ ≠
<b>4. Orientation</b>	<b>1. Horizontal</b>			Horizontal text alignment ABC
	<b>2. Vertical</b>			Vertical text alignment ABC
<b>5. Alignment</b>	<b>1. Left</b>			Left-aligned text ABC
	<b>2. Center</b>			Centered text ABC
	<b>3. Right</b>			Right-aligned text ABC



## Operating elements

Table 3-1 Menu [...]





Level 1	Level 2	Level 3	Level 4	Description
<b>6. Frame</b>	<b>1. No Frame</b>			No frame
	<b>2. Dotted</b>			Frame, dashed line 
	<b>3. Thin</b>			Frame, thin line 
	<b>4. Medium</b>			Frame, standard line 
	<b>5. Thick</b>			Frame, thick line 
<b>7. Margin</b>	<b>1. Least</b>			1 mm
	<b>2. Small</b>			2 mm
	<b>3. Medium</b>			5 mm
	<b>4. Large</b>			10 mm
	<b>5. Text-equal</b>			All margins are adjusted evenly according to the text size
	<b>6. User Set</b>			Set fixed width from right and left margin (1 mm ... 400 mm)
<b>8. Length</b>	<b>1. Auto Length</b>			The length of the printed text depends on the marking and the margin set
	<b>2. User Set</b>			Set fixed length (4 mm ... 400 mm)

Table 3-1 Menu [...]

Level 1	Level 2	Level 3	Level 4	Description	
9. Template	1. Normal			Empty template	
	2. Barcode	Barcode Type	Code 39, Code 128, Interleaved 2/5, Codabar, EAN-8, EAN-13, EAN-128, UPC-A		You can implement Micro-QR-Code, DataMatrix and PDF417 via CLIP PROJECT
		Width	Small, Medium, Large		Barcode width
		Display Text	No, Yes		The text encrypted in the barcode is displayed below the barcode.
		Check Code	No, Yes		A check digit is added, if required
	3. Sequence	Auto Length	StaVal		Start value of a sequence of numbers (2 = 2, 3 ...)
			IncVal		Increment of a sequence of numbers (2 = 2, 4, 6...)
			EndVal		Final value of a sequence of numbers (5 = ... 3, 4, 5)
			SepLine		Separator line
			Orient.		Text alignment of the module: horizontal or vertical
			Prefix		Prefix of a sequence of numbers (-X = -X1, -X2...)
			Suffix		Suffix of a sequence of numbers (-X = 1-X, 2-X...)
		Copies		Repetitions (2 = 1, 1, 2, 2...)	

Table 3-1 Menu [...]

Level 1	Level 2	Level 3	Level 4	Description	
9. Template	3. Sequence	Pitch	StaVal	Start value of a sequence of numbers (2 = 2, 3 ...)	
			IncVal	Increment of a sequence of numbers (2 = 2, 4, 6...)	
			EndVal	Final value of a sequence of numbers (5 = ... 3, 4, 5)	
			Pitch	Factor for the width	
			SepLine	Separator line	
			Orient.	Text alignment of the module: horizontal or vertical	
			Prefix	Prefix of a sequence of numbers (-X = -X1, -X2...)	
			Suffix	Suffix of a sequence of numbers (-X = 1-X, 2-X...)	
	Copies	Repetitions (2 = 1, 1, 2, 2...)			
	4. Module	Total			Number of modules, [1 ... 64] one line, [1 ... 32] two lines
			Pitch		Width for each module, pitch
			Factor		Factor for the width
			SepLine	Dotted, Thin, Medium, Thick, Off	Separator line
			Orient.	Hor., Ver.	Text alignment of the module: horizontal or vertical
	5. Cable Wrap	Horizontal	Auto Length	Length of the cable marking is adjusted according to space available	
			User Set	User-defined length of the cable marking (4 mm ... 400 mm)	
		Vertical	Diameter	Diameter of the cable (4 mm ... 100 mm)	
			Cross section	Cross section of the cable (0.25 mm <sup>2</sup> /AWG 22 ... 50 mm <sup>2</sup> /AWG 0)	

Table 3-1 Menu [...]

Level 1	Level 2	Level 3	Level 4	Description
<b>9. Template</b>	<b>6. Cable Flag</b>	<b>Orient.</b>	<b>Hor., Ver.</b>	Text alignment of the cable flag
		<b>Wrap Length</b>	<b>Diameter</b>	Diameter of the cable (4 mm ... 100 mm)
			<b>Cross section</b>	Cross section of the cable (0.25 mm <sup>2</sup> /AWG 22 ... 50 mm <sup>2</sup> /AWG 0)
		<b>Flag Length</b>	<b>Auto Length, User Set</b>	Length of the cable flag: automatic or user-defined 4 mm ... 400 mm
		<b>Center Line</b>	<b>Off, Dotted, Thin, Medium, Thick</b>	Center line as folding guide
<b>A. Setup</b>	<b>1. Language</b>	English German French Spanish Italian Czech Dutch Hungarian Polish Portuguese Turkish Korean Japanese	Languages for the menu	

## Operating elements

Table 3-1 Menu [...]

Level 1	Level 2	Level 3	Level 4	Description
<b>A. Setup</b>	<b>2. Unit</b>	<b>mm, inch</b>		Units in millimeters or inches
	<b>3. Feed Length</b>	<b>Cur.</b>		Feed length. Default: 10 mm
		<b>Max.</b>		Maximum 400 mm
		<b>Min.</b>		Minimum 4 mm
	<b>4. Display Light</b>	<b>Always On</b>		The display lighting will remain switched on
		<b>Set Time</b>	<b>Cur.</b>	The display lighting is switched off after a specific time. Default: 15 s
			<b>Max.</b>	Maximum 600 s
			<b>Min.</b>	Minimum 15 s
	<b>5. Auto Off</b>	<b>Always On</b>		The device will remain switched on
		<b>Set Time</b>	<b>Cur.</b>	The device is switched off after a specific time. Default: 1 min
			<b>Max.</b>	Maximum 60 min
			<b>Min.</b>	Minimum 1 min
	<b>6. Information</b>	<b>Model</b>		Device type
		<b>Firmware</b>		Firmware version
		<b>Serial Number</b>		Serial number
		<b>Cartridge Type</b>		Type of the inserted material cartridge
<b>Remain Length</b>		The remaining material length (estimated)		
<b>Battery Status</b>		Charging status of the battery		

Table 3-1 Menu [...]

Level 1	Level 2	Level 3	Level 4	Description	
<b>0. Setup</b>	<b>7. Date</b>	<b>Year</b>		Specify the current date	
		<b>Month</b>			
		<b>Day</b>			
		<b>Date Format</b>		Format: day (dd), month (mm), and year (yyyy) Example: dd/mm/yyyy → 23/06/1977 yyyy-mm-dd → 1977-06-23	
	<b>8. Time</b>	<b>Hour</b>		Specify the current time.	
		<b>Minute</b>			
		<b>Second</b>			
		<b>Time Format</b>		24 hour format: hh:mm:ss → 13:24:59  12 hour format: hh:mm:ss am/pm → 01:24:59 pm	
	<b>9. Reset All</b>				Reset to default values

## 4 Creating the marking

### 4.1 Creating the marking on the display

#### 4.1.1 Entering and formatting text

##### Example 1

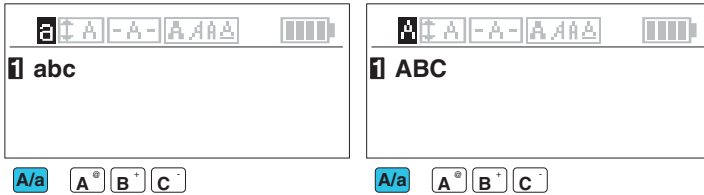

Figure 4-1 Switching between upper case and lower case letters

##### Example 2

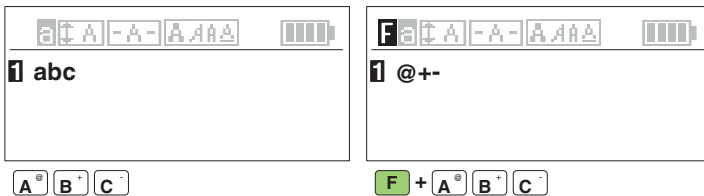

Figure 4-2 Using the alternative key assignment

##### Example 3

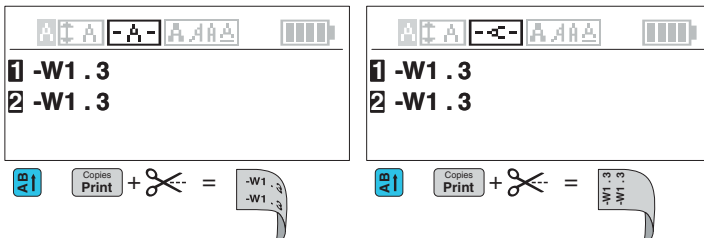

Figure 4-3 Changing the text alignment

**Example 4**

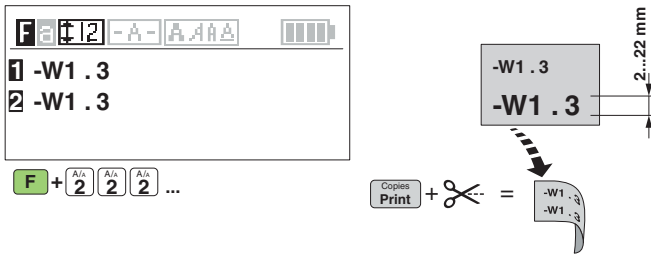

Figure 4-4 Changing font size

**Example 5**

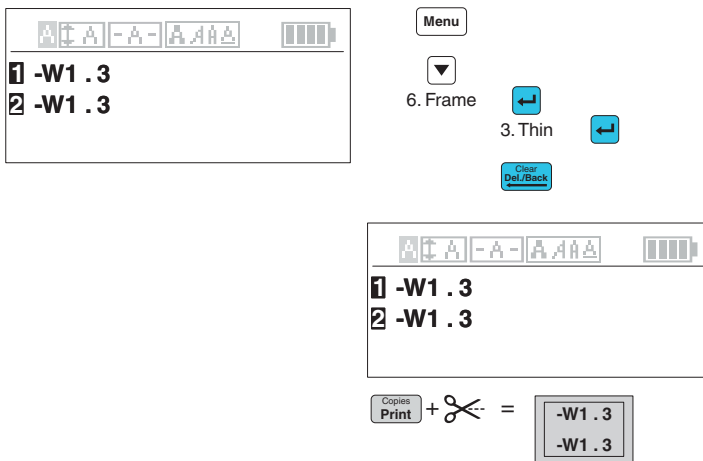





Figure 4-5 Inserting a frame around the text



You can set fixed values, e.g., a fixed width for the margin or a fixed length for the label. To ensure dimension accuracy the printer transports a little piece of material before printing. The printer requests that you cut off this piece before printing.



### 4.1.2 Inserting symbols

- Press the turquoise  key.
- Select a category using the arrow keys.
  - Punctuation marks
  - General symbols
  - Units
  - Electrical general
  - Electrical components
  - Home electrics
  - Safety symbols
  - Superscript characters
  - Subscript characters
  - Arrows
  - Greek upper case letters
  - Greek lower case letters
  - Mathematical symbols
- Press the  key to select an entry. Go back with .
- Choose a symbol with the arrow keys. A selected symbol has a black background.
- Once you have selected a symbol, press the black  key.  
The symbol is accepted and you are returned to the input screen.





An overview of all the symbols available can be found under “Overview of the symbols” on page 43.

### 4.1.3 Inserting barcode

You can arrange for labels to be marked with a barcode. Move the cursor to the position at which the sequence is to be located.



If you select this template, the entered marking will be deleted. First create the template and then enter the marking.





- Press the turquoise  key.
- Select “2. Barcode” . Press the  key.
- Select the required settings (see below).
- Press the  key to select an entry. Go back with  or  key.

Selection		Possible entry	Example
<b>Barcode Type</b>	You can implement Micro-QR-Code, DataMatrix and PDF417 via CLIP PROJECT	[Code 39, Code 128, Interleaved 2/5, Codabar, EAN-8, EAN-13, EAN-128, UPC-A]	
<b>Width</b>	Barcode width	[Small, Medium, Large]	
<b>Display Text</b>	The text encrypted in the barcode is displayed below the barcode	[No, Yes]	
<b>Check Code</b>	A check digit is added, if required	[No, Yes]	

“Bar.” is displayed on the input screen.

### 4.1.4 Numbering labels automatically

You can arrange for labels to be marked with continuous numbers or letters. Move the cursor to the position at which the sequence is to be located.

- Press the turquoise  key.
- Select “3. Sequence” . Press the  key.
- Select the required settings (see below).
- Press the  key to select an entry. Go back with  or  key.

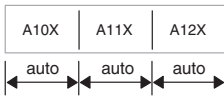
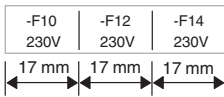
Selection A		Example
<b>Auto Length</b>	The length of the printed text depends on the marking and the margin set	
<b>Pitch</b>	A width can be determined for each sequence	

### Determining sequence

Selection B		Possible entry	Example
<b>StaVal</b>	Start value	[1 ... 99, aa ... zz, AA ... ZZ]	9 = 9, 10, 11 ... 99
<b>IncVal</b>	Increment	[1 ... x]	2 = 2, 4, 6, 8 ... 98
<b>EndVal</b>	Final value	[1 ... 99, aa ... zz, AA ... ZZ]	40 = ... 38, 39, 40
<b>Pitch</b> Not available for „Auto Length“	Width for each module	[4 ... 1000.0 in steps of 0.1 mm, mm or inches]	
<b>SepLine</b>	Separator line	[Dotted, Thin, Medium, Thick, Off]	
<b>Orient.</b>	Text alignment of the module	[Hor., Ver.]	
<b>Prefix</b>	Prefix	[max. 20 characters]	-X = -X1,- X2, -X3,...
<b>Suffix</b>	Suffix		Y = 1Y, 2Y, 3Y ...
<b>Copies</b>	Number of repetitions for each value	[1 ... 99]	3 = 1, 1, 1, 2, 2, 2







“Seq.” is displayed on the input screen.

### 4.1.5 Creating label modules with a fixed width

To label electronic modules, such as terminal blocks or fuses, one label can be printed for all modules. A width (“Pitch”) can be determined for each module.



If you select this template, the entered marking will be deleted. First create the template and then enter the marking.

- Press the turquoise  key.
- Select “4. Module”. Press the  key.
- Select the required settings (see page 29).
- Press the  key to select an entry. Go back with  or  key.
- „Mod“ appears on the screen.
- Use the arrow keys to select a module and add your marking. If you create three module e.g. „Page01“, „Page02“, „Page03“.
- To leave the „Module“ template, press the green function key  + .

**Example 1**

**Total**  
**Pitch + Factor**

F1 230 V	F2-4 400 V	F5 230 V
1	2	3
1 x 17.5 mm	3 x 17.5 mm	1 x 17.5 mm
Medium		
Horizontal		

**SepLine**  
**Orient.**

**Example 2**

**Total**  
**Pitch + Factor**  
**SepLine**  
**Orient.**

L1	L2	L3	N
1	2	3	4
1 x 8.5 mm			
Thick			
Vertical			

## Operating elements

---

Selection		Possible entry	Example
<b>Total</b>	Number of modules	[1 ... 64] one line, [1 ... 32] two lines	12 = 12 modules next to each other
<b>Pitch</b>	Width for each module	[4 ... 1000.0 in steps of 0.1 mm, mm or inches]	10.1 = 10.1 mm wide modules
<b>Factor</b>	Factor for the width	[1 ... 9, in steps of 0.5], factor for the width	2.5 = width x 2.5
<b>SepLine</b>	Separator line	[Dotted, Thin, Me- dium, Thick, Off]	
<b>Orient.</b>	Text alignment of the module	[Hor., Ver.]	

### 4.1.6 Creating cable marking

When marking cables or conductors, it may be useful to attach a marking that is readable around the cable.

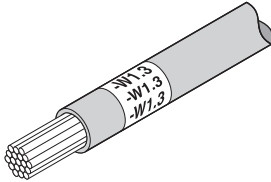

Figure 4-6 Cable marking



If you select this template, the entered marking will be deleted. First create the template and then enter the marking.

- Press the turquoise **Tem-plate** key.
- Select "5. Cable Wrap" . Press the **↵** key.
- Select the required settings (see below).
- Press the **↵** key to select an entry. Go back with **Clear/Del/Back** or **Menu** key.
- You can select measurements with the arrow keys. Some measurements can also be entered directly by using the number keys.

The following settings can be made:

Selection		Possible entry	Example
5. Cable Wrap	Horizontal text alignment	[Auto Length, User Set]	
	Vertical text alignment	[Diameter, Cross section]	

When using **horizontal text alignment**, the optimum width of the label can be determined automatically or you can specify a fixed width.

When using **vertical text alignment**, enter the diameter or the cross section of the cable. The printer then determines the optimum length.

### 4.1.7 Creating cable flags

For large-area marking of cables, cable flags can be used. To do so, enter the marking for the front side. The back side is printed automatically with the same marking.



Figure 4-7 Example of a cable flag



If you select this template, the entered marking will be deleted. First create the template and then enter the marking.

- Press the turquoise **Tem-plate** key.
- Select “6. Cable Flag” . Press the **↔** key.
- Select the required settings (see below).
- Press the **↔** key to select an entry. Go back with **Clear Del./Back** or **Menu** key.
- You can select measurements with the arrow keys. Some measurements can also be entered directly by using the number keys.

The following settings can be made:

Selection		Possible entry	Example
<b>Orient.</b>	Text alignment	[Hor., Ver.]	
<b>Wrap Length</b>	Diameter or cross section of the cable	[Diameter, Cross section]	
<b>Flag Length</b>	Length of the cable flag	[Auto Length, User Set]	
<b>Center Line</b>	Center line	[Off, Dotted, Thin, Medium, Thick]	

Enter the diameter or the cross section of the cable. The printer then determines the optimum length. Alternatively, you can specify a fixed length for the flag.

## 4.2 Creating the marking on the PC

CLIP PROJECT Marking can be used to create markings on a PC which are tailored to the Phoenix Contact marking material.

Select the THERMOFOX as the printer. You will be provided with a template list of materials that are suitable for this printer.

The CLIP PROJECT Marking software is supplied with the printer. The marking software is also available for download at [phoenixcontact.net/qr/5146040](http://phoenixcontact.net/qr/5146040).

### Connecting to a computer via USB



**NOTE: Errors during operation due to insufficient or missing shielding**  
Make sure that all connecting cables connected to the printer are shielded.

A printer driver must be installed if a USB interface is to be used for connection. You will find the printer driver on the DVD-ROM that is supplied with the printer or on the Internet at [phoenixcontact.net/qr/0803984](http://phoenixcontact.net/qr/0803984).

- Switch on the PC.
- Exit all programs that are currently running.
- Switch on the THERMOFOX.
- Connect the PC to the THERMOFOX using the supplied USB cable.
- Insert the DVD containing the driver software. The Windows installation wizard is started automatically.
- Follow the on-screen instructions.



Following successful installation, an icon for the THERMOFOX appears in the Windows "Devices and Printers" system folder

Then set up the THERMOFOX in CLIP PROJECT Marking.

Add the THERMOFOX as a printer. For instructions, please refer to the quick start guide, Part 01 on the basics of CLIP PROJECT Marking. The quick start guide can be downloaded at [phoenixcontact.net/qr/5146040](http://phoenixcontact.net/qr/5146040).



### 4.3 Printing

- Press the  key, to print the marking once.
- To print multiple copies, press the  key and the green  function key simultaneously.
- If you choose multiple copy, select whether to cut now or later.  
If you choose to cut later, the printer can add a line at the cutting position.  
If you choose the cutting option, you will be asked to cut. After cutting the device continues printing.

## 5 Maintenance and troubleshooting

### 5.1 Cleaning

#### 5.1.1 Cleaning the printer



**NOTE: Damage to the printer due to abrasive cleaning agents**

Do not use abrasive cleaners or aggressive solvents for cleaning the outer surfaces.

- Remove dust and paper fluff in the printing area with a soft brush.
- Clean the outer surfaces with a damp cloth. Use an all-purpose cleaner for heavier contamination.

### 5.1.2 Cleaning the print head and print roller

During printing, substances may be deposited on the print head or print roller. It is important to clean the print head and print roller regularly. This keeps the printing quality at the same level and the service life is increased.

**NOTE: Damage to the print head**

Do not touch the protective glass of the print head with your fingers or sharp objects. Do not use sharp or hard objects to clean the print head.

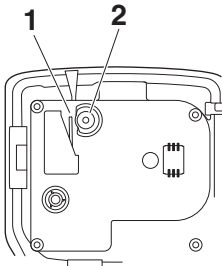

Figure 5-1 Print head (1) and print roller (2)

- Open the cover of the material cartridge and remove the material cartridge.
- Clean the print head line and print roller with a felt stick (e.g., CLEANING STICK, 5146697) soaked in isopropyl alcohol.
- Allow the print head to dry for two to three minutes.

## 5.2 Troubleshooting

Table 5-1 Troubleshooting

Problem	Possible cause	Remedy
Print image is blurred or missing in places	Print head or print roller is dirty	Clean the print head and print roller (see 5.1.2)
	The tension of the ink ribbon is too low	To increase the tension of the material, turn the ink ribbon coil
Material is not supplied	The material is not pulled out far enough from the material cartridge	Unwind the material approx. 5 mm off the material cartridge. To increase the tension of the material, turn the ink ribbon coil
	Material is stuck in the printer	Carefully remove the material from the printer. Cut off damaged material. Unwind the material approx. 5 mm off the material cartridge. To increase the tension of the material, turn the ink ribbon coil
	Material cartridge is empty	Insert new material cartridge (see 2.4)
	Compartment for material cartridge is open	Close compartment
Material is supplied but not printed	Ink ribbon is torn	Insert new material cartridge (see 2.4)
Printer too loud	Material cartridge is not inserted correctly	Insert material cartridge correctly (see 2.4)
	Material cartridge is defective	Insert new material cartridge (see 2.4)
	Compartment for material cartridge is open	Close compartment
Printer prints slowly	Printing speed is automatically set	If the battery charge is too low the printing speed is reduced. This ensures a high-quality print

Table 5-1 Troubleshooting

<b>Problem</b>	<b>Possible cause</b>	<b>Remedy</b>
The printer cannot be switched on	Batteries are empty	Change batteries
	Batteries are inserted incorrectly	Insert batteries correctly
	Rechargeable battery is empty	Recharge battery
	Rechargeable battery is inserted incorrectly	Insert rechargeable battery correctly
	No power supply	Connect the power supply unit
Printer switches off automatically	Auto off function is activated	Check menu entry (see "A. Setup, 5. Auto Off")
Battery is not charged	Battery is inserted incorrectly	Insert battery correctly
	No power supply	Connect the power supply unit
	Rechargeable battery is defective	Dispose of battery properly and insert new battery

Table 5-1 Troubleshooting

<b>Problem</b>	<b>Possible cause</b>	<b>Remedy</b>
Display lighting switches off automatically	Auto off function of the display lighting activated	Check menu entry (see "A. Setup, 4. Display Light")
No input possible	General system error	Switch device off and on. Disconnect the device from power supply. Remove batteries. Insert new ones
Cutting is stiff	Type of material being used	Some materials have a higher material thickness. These materials need more cutting force than other materials

### 5.2.1 Error messages

Table 5-2 Error messages

Error message	Possible cause	Remedy
“Cutter Error”	Cutter was used while printer was printing. Printing is interrupted.	Press any key (except <input type="button" value="ON/OFF"/> or <input type="button" value="Light"/> )
“End of Tape”	Material cartridge is empty	Insert new material cartridge
“Input Too Long”	The limit on the number of characters that can be printed has been reached	Reduce number of characters or increase label length
“No Cartridge“	No material cartridge inserted	Insert the material cartridge
“No Lines Left”	The limit on the number of lines that can be printed on has been reached	Reduce number of lines or use wider material
“No Tape”	Material cartridge not found	Insert new material cartridge
“Please Cut”	Printer is waiting for the material to be cut	Activate the cutter. Press any key to continue
“Press Any Key”	Printer is awaiting input	Press any key (except <input type="button" value="ON/OFF"/> or <input type="button" value="Light"/> )

## 5.3 Repairs



**WARNING: Risk to operational reliability**

Incorrect operation or modifications to the device can endanger your safety or damage the printer. Do not repair the product yourself. If the device is defective, please contact Phoenix Contact.

## 5.4 Firmware update

To benefit from updates or extended functions, a firmware update and a firmware update tool can be downloaded at [phoenixcontact.net/qr/0803984](https://phoenixcontact.net/qr/0803984).

## 5.5 Disposal



The device contains valuable recyclable materials, which should be utilized.

Dispose of the printer separately from other waste, i.e., via an appropriate collection site.



Dispose of the battery separately from other waste, i.e., via an appropriate collection site.



# 6 Appendix

## 6.1 Technical data

Technical data	
Resolution	203 dpi
Print mode	Thermal transfer
Print speed	12 mm/s
Print length	4 mm ... 2200 mm
Print width, maximum	24 mm
Interfaces	USB
Display and operation	2.5" LCD display, ABC keyboard
Voltage	100 V AC ... 240 V AC, 50/60 Hz
Power	36 W, maximum
Temperature	
Operation	+5°C ... +40°C
Storage	-18°C ... +60°C
Transport	-25°C ... +60°C
Humidity	
Operation	10 % ... 90 %
Storage	5 % ... 90 %
Transport	5 % ... 95 %
Approvals	CE, UL, FCC-B, ICES
Approval for Canada as per ICES-003	CAN ICES-3 (B)/NMB-3(B)
Dimensions (H x D x W)	230 mm x 98 mm x 69 mm
Weight	656 g

## 6.2 Ordering data for accessories

### Accessories

Description	Type	Order No.	Pcs./Pkt.
<b>Battery</b> , to supply the THERMOFOX with power	THERMOFOX/ACCU	0805009	1
<b>Charger</b> , for charging the THERMOFOX/ACCU	THERMOFOX/CHARGER	0805012	1
<b>Wide range power supply unit</b> , with four socket adapters	THERMOFOX/ADAPTER	0805010	1
<b>Transport case</b> , for transporting the THERMOFOX	THERMOFOX/CASE	0805002	1
<b>Bag</b> , for transporting the THERMOFOX	THERMOFOX/BAG	0805003	1
<b>Belt clip</b> , for fastening on a belt	THERMOFOX/BELT CLIP	0805004	1
<b>Magnet</b> , for fastening on e.g. control cabinet	THERMOFOX/MAGNET HOLDER	0805008	1

## 6.3 Overview of the symbols

Table 6-1 Overview of the symbols

Category	Symbols
<b>Punctuation</b>	! " # & ' ( ) * , . / : ; ? [ \ ] ^ _ {   } ~ ¿ ¡ ' , “ ”
<b>General symbols</b>	§ © ® ° μ ¶ @
<b>Units</b>	\$ £ ¢ ¤ ¥ € ° ´ ¨ % ‰ °C °F μm mm cm km ft mm² cm² m² km² mm³ cm³ m³ mg kg ml dl μV mV kV μA mA kA mW kW MW mW kW MW pF nF μF Hz kHz MHz GHz dB Pa ha mb
<b>Electr. General</b>	
<b>Electr. Comp.</b>	
<b>Home Electrics</b>	

Table 6-1 Overview of the symbols

Category	Symbols																																										
<b>Safety Signs</b>																																											
<b>Superscript</b>	<table border="1"> <tr> <td>±</td><td>-</td><td>+</td><td>0</td><td>1</td><td>2</td><td>3</td><td>4</td><td>5</td><td>6</td><td>7</td><td>8</td><td>9</td><td>a</td><td>b</td><td>c</td><td>d</td><td>e</td><td>f</td><td>g</td> </tr> <tr> <td>h</td><td>i</td><td>k</td><td>l</td><td>m</td><td>n</td><td>o</td><td>q</td><td>r</td><td>s</td><td>t</td><td>u</td><td>v</td><td>w</td><td>x</td><td>y</td><td>z</td><td>α</td><td>β</td><td>γ</td> </tr> </table>	±	-	+	0	1	2	3	4	5	6	7	8	9	a	b	c	d	e	f	g	h	i	k	l	m	n	o	q	r	s	t	u	v	w	x	y	z	α	β	γ		
±	-	+	0	1	2	3	4	5	6	7	8	9	a	b	c	d	e	f	g																								
h	i	k	l	m	n	o	q	r	s	t	u	v	w	x	y	z	α	β	γ																								
<b>Subscript</b>	<table border="1"> <tr> <td>±</td><td>-</td><td>+</td><td>0</td><td>1</td><td>2</td><td>3</td><td>4</td><td>5</td><td>6</td><td>7</td><td>8</td><td>9</td><td>a</td><td>b</td><td>c</td><td>d</td><td>e</td><td>f</td><td>g</td><td>h</td> </tr> <tr> <td>i</td><td>j</td><td>k</td><td>l</td><td>m</td><td>n</td><td>o</td><td>p</td><td>q</td><td>r</td><td>s</td><td>t</td><td>u</td><td>v</td><td>w</td><td>x</td><td>y</td><td>z</td><td>α</td><td>β</td><td>γ</td> </tr> </table>	±	-	+	0	1	2	3	4	5	6	7	8	9	a	b	c	d	e	f	g	h	i	j	k	l	m	n	o	p	q	r	s	t	u	v	w	x	y	z	α	β	γ
±	-	+	0	1	2	3	4	5	6	7	8	9	a	b	c	d	e	f	g	h																							
i	j	k	l	m	n	o	p	q	r	s	t	u	v	w	x	y	z	α	β	γ																							
<b>Arrows</b>																																											

## Operating elements

Table 6-1 Overview of the symbols

Category	Symbols
Greek Upper Case	Α Β Γ Δ Ε Ζ Η Θ Ι Κ Λ Μ Ν Ξ Ο Π Ρ Σ Τ Τ Υ Φ Χ Ψ Ω
Greek Lower Case	α β γ δ ε ζ η θ ι κ λ μ ν ξ ο π ρ ς σ τ υ φ χ ψ ω
Mathematical	% + - < = ≠ > ≤ ≥ ± ² ³ ¹ ° ¼ ½ ¾ ÷ ‰ × I II III IV V VI VII VIII IX X

## 6.4 Approvals

### 6.4.1 FCC

The printer complies with the requirements of FCC Part 15 (B) Rules.

Operation is subject to the following two conditions:

- (1) This device may not cause harmful interference, and
- (2) This device must accept any interference received, including interference that may cause undesired operation.

### 6.4.2 UL



**WARNING: Hazardous moving parts**

Keep fingers and other body parts away.