

Product Specification

108-5134

AMP-MODU "J" Series Connector
(Lever Lock Type)

1. Scope:

This specification covers product performance requirements and test methods of AMP-MODU "J" Series Connector (lever lock type) of the following part numbers.

Part Numbers	Part Name	Descriptions
172756-X	Receptacle Contact	AWG #22-26,
170433-X		AWG #26-28,
170435-X		" #20-24,
170437-X		" #20-24,
171275-1, -3		" #20-24,
172145-X	Receptacle Housing	with Locking Ears
172091-X	AMP-LATCH "J" Series, Post Header Vertical Type	w/o External Locking Lever
172092-X		w/ External Locking Lever
172093-X	AMP-LATCH "J" Series, Post Header Horizontal Type	w/o External Locking Lever
172094-X		w/ External Locking Lever
173210-X	Receptacle Housing	Panel-Mounting Type

2. Applicable Documents:

2.1 The following standard and specifications form part of this specification to the extent specified herein.

2.1.1 Military Standard/Specifications and Federal Specifications:

MIL-STD-202 Test Methods for Electronic and Electrical Component Parts
MIL-B-45204 Electrodeposited Gold-Plating

2.1.2 Federal Specifications:

QQ-C-533 Copper-Beryllium Alloy Strip
QQ-N-290 Electrodeposited Nickel Plating
QQ-B-750 Phosphor Bronze Strip

2.1.3 Japanese Standard:

JIS-H-3521 Brass Wires

3. For the purpose of this specification, the following terms shall apply.

3.1 Receptacle Contact:

Electrically conductive metallic component, having stamped form as a female contact with "U" barrels to crimp wire conductor and insulation. Frictional contact area is formed in a square box configuration, and a pair of cantilever springs to make electrical contact with pin contact when mated. The receptacle contact is also featured to have a locking lance to retain with when installed in housing cavity. Improved back-up mechanism is provided on the lance of 172656-X.

E	Revised RFA-857	DR	1-21-81	 AMP (Japan), Ltd. TOKYO, JAPAN	LCC NO J A 108-5134	REV E
D	Revised RFA-826	CHK	1-21-81			
C	RFA-730	APP	1-21-81			
B	Revised RFA-614	DR	1-21-81			
A	Revised per RFA-446	DR	1-21-81			
LTR REVISION RECORD		DR	CHK	DATE	SHEET 1 OF 10 NAME Product Specification AMP-MODU "J" Series, Connector (Lever Lock Type)	

NUMBER 108-5134

Customer Release
AMP SECURITY CLASSIFICATION

PRINT LIST

3.2 Receptacle Housing:

An electrically insulating multi-pole connector housing that is plastic molded by using the material specified in Para. 4.2, to encapsulate receptacle contacts in the cavities with the center line spacing disposition in 2.54mm laterally and longitudinally.

3.3 Post Header Assembly:

AMP-LATCH "J" Series post headers having 0.64mm dia. posts implanted with the center line spacing of 2.54mm are used for this application. The root portion of pin contacts is inserted in the printed circuit board hole and soldered, and tip end of the pin contact engages with receptacle contact to complete circuitry. The housings of both vertical and horizontal types with the locking levers to lock the mated housing, are available.

3.4 Connector Assembly:

Connector Assembly is an assembly of receptacle contact-loaded housing and pin contact-loaded post header adequately engaged to complete circuitry.

4. Material and Finish:**4.1 Receptacle Contact:**

- 4.1.1 Material: Beryllium-Copper Alloy conforming to QQ-C-533
Phosphor Bronze conforming to QQ-B-750
- 4.1.2 Finish: Gold strip plating having thickness of 0.4 μ m or 0.76 μ m min. or gold selective gold plating having thickness of 0.4 μ m average, conforming to MIL-G-45204, over nickel underplate having thickness of 0.4 - 1.0 μ m or 1.3 - 2.5 μ m conforming to QQ-N-290; Tin-plating 0.8 μ m minimum

4.2. Receptacle Housing and Post Housing:

- 4.2.1 Material: Glass-filled polybutylene terephthalate resin, conforming UL Fire Retardant Grade of UL 94V-0.

4.3 Post Contact:

- 4.3.1 Material: Brass Wire #4, conforming to JIS H 3521
- 4.3.2 Finish: (a) Gold-plating 0.2 μ m, 0.4 μ m and 0.8 μ m min. thick over 1.3 μ m min. nickel underplate,
(b) Bright tin plating 0.8 μ m min. over 0.8 μ m min. bright nickel underplate

5. Appearance and Color:**5.1 Appearance:**

Product must appear normal without showing evidence of defects such as damages, breakage, deformation, blister dirt and burrs that are detrimental to connector functions and cosmetic appearance.

5.2 Color:

Housing color must be black as specified.

SHEET			AMP (Japan), Ltd. TOKYO, JAPAN	
2 OF 10	LOC J A	NO 108-5134	REV E	
NAME Product Specification AMP-MODU "J" Series, Connector (Lever Lock Type)				

NUMBER 100 5134
 Customer Release
 AMP SECURITY CLASSIFICATION

6. Product Design Feature, Construction and Dimensions:

Product Design Feature, construction and dimensions shall be conforming to the applicable customer product drawing(s). Major features of the product are specified as follows.

- (1) Number of Connector Positions: 10, 16, 20, 26, 34, 40 and 50 Positions
- (2) Center Line Spacing: 2.54mm x 2.54mm Dual Line
- (3) Type of Post Header Assemblies: Vertical and Horizontal
- (4) Mounted Method of Post Header: Screw on printed circuit board and soldered
- (5) Mounting Method of Receptacle Housing (Panel-Mounting Type): Screw on the panel.
- (6) Applicable Wire Size: AWG #20 - #28,
Insulation diameter: 0.89 - 1.77mm

7. Performance:

7.1 Rated Performance:

- Temperature Rating: 105°C - -55°C
- Current Rating: 3.5A for AWG#20-24, 2A for AWG#26-28 Wire

7.2 Electrical Performance:

Test Items (Paragraph No.)	Specified Requirement	Summary of Test Method
Termination Resistance (Low Level) (Para. 7.2.1)	18mΩ Maximum (Gold plated contacts) 20mΩ Maximum (Tin plated products)	Termination resistance of contact is tested in accordance with Test Method 307 of MIL-STD-202 by applying closed circuit current of 50mA max. at open circuit voltage of 50mV flowing through the circuit formed as specified in Fig. 2. From the measured reading, the resistance of 75mm-long wire must be deducted. Calculate termination resistance.
Insulation Resistance: (Para. 7.2.2)	5,000MΩ min.	Insulation resistance of mated pair of connector assemblies must be measured in accordance with Test Condition "B", Test Method 302 of MIL-STD-202 by applying test potential between the adjacent contacts and between the opposing side contacts. Measurement shall be done on randomly selected 4 pairs of contacts.

SHEET				AMP (Japan), Ltd. TOKYO, JAPAN	
3	OF 10			LOG	NO
		J	A	108-5134	E
NAME Product Specification					
AMP-MODU "J" Series Connector (Lever Lock Type)					

7.2 Electrical Performance:

NUMBER 108-5134
 AMP SECURITY CLASSIFICATION
 Customer Release

Test Items (Paragraph No.)	Specified Requirements	Summary of Test Method
Dielectric Strength (Para. 7.2.3)	Connector assembly shall withstand test potential for 1 minute without showing abnormalities such as insulation breakdown and flashover on connector surfaces.	Dielectric strength of mated pair of connector assemblies shall be tested in accordance with Test Method 301 of MIL-STD-202 by applying test potential between the adjacent and opposing contact increasing at a rate of 500V/sec.AC until the specified limit at 500V is reached. Hold at 500V for 1 minute and inspect for evidence of abnormalities.
Temperature Rising: (Para. 7.2.4)	105°C max.	Before energizing test current, a 1.5mm dia. hole is made through the wall of housing cavity at the portion where wire barrel is positioned as shown in Fig. 3. Then, apply test current of the value specified in Table 1. Measure the temperature rising of contact by probing on five contacts in the interior disposition after the temperature rising of connector becomes stabilized. The measured value must not exceed the maximum limit specified in Table 1 in Para 7.1.

7.3 Physical Performance:

Test Items (Paragraph No.)	Specified Requirements	Summary of Test Method
Connector Insertion and Extraction Force (Para. 7.3.1)	Insertion Force: 370 g (max.) Extraction Force: 30 g (min.) (Gold plated products)	A mating pair of connector assemblies shall be fastened on the tensile testing machine in the manner they are to mate and unmate as the head is operated. Measure the force required to engage and separate without locking legs set in effect. Measured value must be divided by the number of contact positions to obtain averaged insertion/extraction force of one contact position of connector.
	Insertion Force: 450 g (max.) Extraction Force: 30 g (min.) (Tin plated products)	

SHEET				AMP (Japan), Ltd. TOKYO, JAPAN	
4 OF 10		LOC J	NO A	NO 108-5134	REV E
NAME Product Specification					
AMP-MODU "J" Series Connector (Lever Lock Type)					

Test Items (Paragraph No.)	Specified Requirements	Summary of Test Methods	
Durability (Repeated Insertion and Extraction) (Para. 7.3.2)	Appearance: After test conditioning, connector assembly shall show no abnormalities and damages.	In the same manner as specified in Para. 7.3.1, repeat insertion and extraction of contacts for the cycles shown below.	
		Plating Type Number of Cycles	
	Termination Resistance (min.)	Gold Tin 18mΩ 20mΩ	
	Insertion/ Extraction Force:	Para. 7.3.1 shall be met.	
Vibration (Para. 7.3.3)	During vibratile testing, electrical discontinuity greater than 1 μsecond shall occur, and shall show no abnormalities such as breakage, damage and loose of parts in the connector.	Mated pair of connector assemblies shall be tested in accordance with Test Method 201A of MIL-STD-202, by applying vibration on testing ma- chine where sample connector is supported without allowing termi- nated wires to touch the plate. During the test, all the contacts shall be series wired and monitor- ed for electrical discontinuity greater than 1 μsecond with the use of test current of 0.1A flow- ing through the circuit.	
Retention Force of Receptacle Contact:	Receptacle contact shall be not dislodged from the con- tact position within 1.5kg.	Fasten contact-loaded connector on tensile testing machine and apply an axial pull off load to the end of crimped wire by operating the head to travel with the speed at a rate of 100mm a minute. The force required to dislodge the contact shall be measured and recorded.	
Crimp Tensile Strength: (Para. 7.3.5)	Wire Size	Crimp Tensile	Wire crimped contact shall be fastened on the tensile testing ma- chine and an axial pull-off load shall be applied to the end of crimped wire by operating the head to travel with the speed at a rate of 100mm a minute. Crimp tensile strength is determined when the wire is broken or is dislodged from the wire crimp.
	mm ² (AWG)	Strength (kg)	
	0.5 (#20)	7.9 min.	
	0.3 (#22)	4.9 "	
	0.2 (#24)	3.1 "	
	0.14 (#26)	1.8 "	
0.085 (#28)	1.2 "		

SHEET			AMP (Japan), Ltd. TOKYO, JAPAN
5 OF 10	LOC J	NO A	108-5134
NAME Product Specification AMP-MODU "J" Series Connector (Lever Lock Type)			
			REV E

108-5134

Customer Release

AMP SECURITY CLASSIFICATION

Test Items (Paragraph No.)	Specified Requirements	Summary of Test Methods
Soldering Heat Resistibility: (Para. 7.3.6)	After test conditioning, sample shall show no abnormalities such as rattling of post, cracks and deformation of housing.	Soldering heat resistibility shall be tested in accordance with Test Condition "B" (260°C, 10 seconds), Test Method 210 of MIL-STD-202 by immersing tyres of post header into soldering tub to a depth of 1mm clearance to housing wall for the time of 10±1 seconds. Soldering tub shall be controlled at 260±5°C.

7.4 Environmental Performance:

Test Items (Paragraph No.)	Specified Requirements	Summary of Test Methods
Thermal Shock: (Para. 7.4.1)	After conditioning, connector shall show no evidence of cracks, warpage and bend however changes of color and surface tactility are not causing for rejection. Insertion/extraction function of connector shall be kept feasible after testing	Mated pair of connector assemblies shall be tested in accordance with Test Condition "A", Test Method 107 of MIL-STD-202 excepting upper temperature limit to be +105°C. After specified thermal test cycling, appearance inspection and functional test shall be performed.
Humidity:(Steady State) (Para. 7.4.2)	After test conditioning, Insulation Resistance	Mated pair of connector assemblies shall be tested in accordance with Test Condition "B", Test Method 103 of MIL-STD-202. After completion of test duration, sample shall be reconditioned in the room temperature for 24 hours, before undergoing subsequent measurements.
	Dielectric Strength	
	Termination Resistance (Low Level)	
	Plating Type	
Salt Spray: (Para. 7.4.3)	After test conditioning, evidence of abnormalities such as remarkable corrosion and physical defects shall be present.	Mated pair of connector assemblies shall be tested in accordance with Test Condition B, Test Method 101 of MIL-STD-202. After completion of test duration, sample connector shall be rinsed in tap water and dried in room temperature without aid of powered ventilation.
	Termination Resistance (Low Level)	
	Plating Type	

SHEET			AMP (Japan), Ltd. TOKYO, JAPAN	
6 OF 10	LOC J	NO A	108-5134	REV E
NAME Product Specification				
AMP-MODU "J" Series Connector (Lever Lock Type)				

8. Test Conditions:

8.1 Environmental Conditions:

Unless otherwise specified, all the tests shall be performed under any combination of the following conditions:

Temperature: 15 - 35°C
 Relative Humidity: 45 - 75%
 Atmospheric Pressure: 650 - 800 mmHg

8.2 Test Specimens:

8.2.1 Test specimens to be used for testing under this product specification shall be prepared by using products selected from the current production at random that are conforming to the applicable product drawing(s).

SHEET			AMP (Japan), Ltd. TOKYO, JAPAN
<u>7</u> OF <u>10</u>	LOC J A	NO 108-5134	REV E
NAME Product Specification AMP-MODU "J" Series Connector (Lever Lock Type)			

9. Test Sequence:

NUMBER 108-5134
 CUSTOMER Release
 AMP SECURITY CLASSIFICATION

Test Items	Para-graph No.	Connector Assemblies					Post Header	Crimped Contact
		1	2	3	4	5	6	7
Appearance (Initial)	5.1	(1)	(1)	(1)	(1)	(1)	(1)	(1)
Termination Resistance (Low Level) (Initial)	7.2.1	(3)	(2)		(2)	(2)		
Insulation Resistance (Initial)	7.2.2		(3)					
Dielectric Strength (Initial)	7.2.3		(4)					
Temperature Rising	7.2.4			(2)				
Connector Insertion and Extraction Force (Initial)	7.3.1	(2)						
Durability, (Repeated Insertion/Extraction)	7.3.2	(4)						
Vibration	7.3.3	(6)				(3)		
Receptacle Contact Retention Force	7.3.4			(4)				
Crimp Tensile Strength	7.3.5							(2)
Soldering Heat Resistibility	7.3.6						(2)	
Thermal Shock	7.4.1		(5)					
Humidity (Steady State)	7.4.2		(7)					
Salt Spray	7.4.3	(9)			(3)			
Termination Resistance (Low Level) (Final)	7.2.1	(8, 10)	(8)		(4)	(4)		
Insulation Resistance (Final)	7.2.2		(9)					
Dielectric Strength (Final)	7.2.3		(10)					
Connector Insertion/Extraction Force (Final)	7.3.1	(5)						
Appearance (Final)	5.1	(7, 11)	(6)	(3)	(5)	(5)	(3)	
Number of Specimens		5 Sets	5 Sets	2 Sets	3 Sets	3 Sets	5 Sets	10 Pcs

(Note:)

1. Tests are performed in accordance with the sequence shown in the columns above.
2. Sample Group 3 shall consist of two sets of specimens each prepared for accepting the wires of AWG #20-24 and #26-28 respectively.
3. Sample Group 5 shall consist of crimped contacts prepared for each wire size used for termination of specimens.
4. Gold-plated contacts shall be omitted from the Sample Groups 4 and 5. Tin-plated contacts shall be included in the Sample Groups 1 through 7. However, the test items No. 6, 7, 8 and 9 in the Sample Group 1 shall be omitted.

SHEET			AMP (Japan), Ltd. TOKYO, JAPAN	
8. OF 10	LOC J A	NO 108-5134	REV E	
NAME Product Specification AMP-MODU "J" Series Connector (Lever Lock Type)				

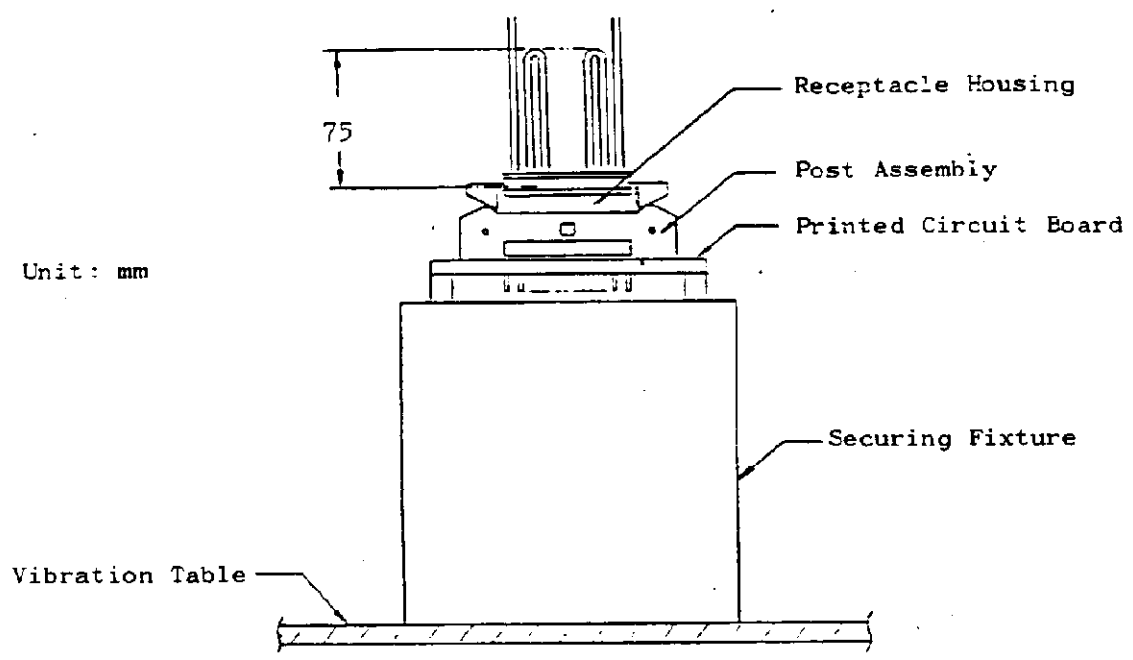

Fig. 1 Vibration Testing

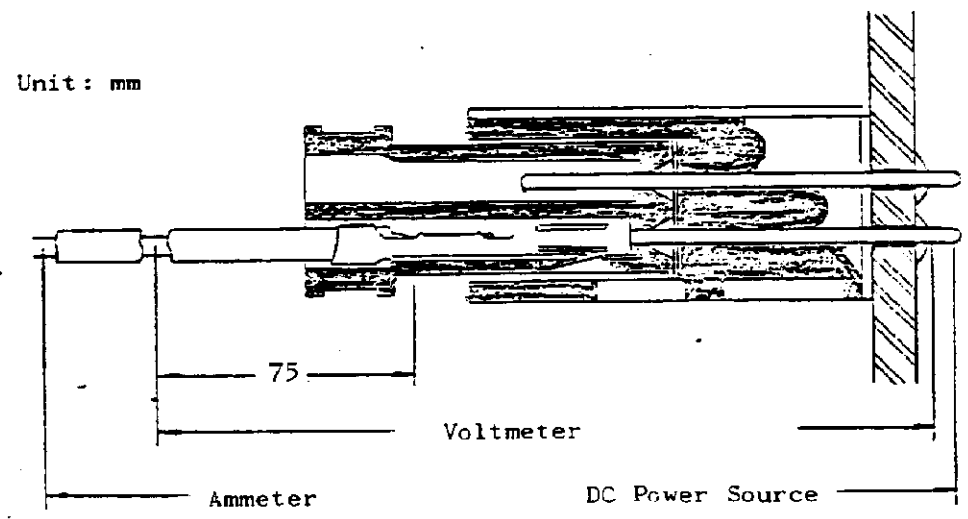

Fig. 2 Termination Resistance Testing

SHEET	AMP		AMP (Japan), Ltd. TOKYO, JAPAN
9 OF 10	LOC J A	NO 108-5134	REV E
NAME Product Specification AMP-MODU "J" Series Connector (Lever Lock Type)			

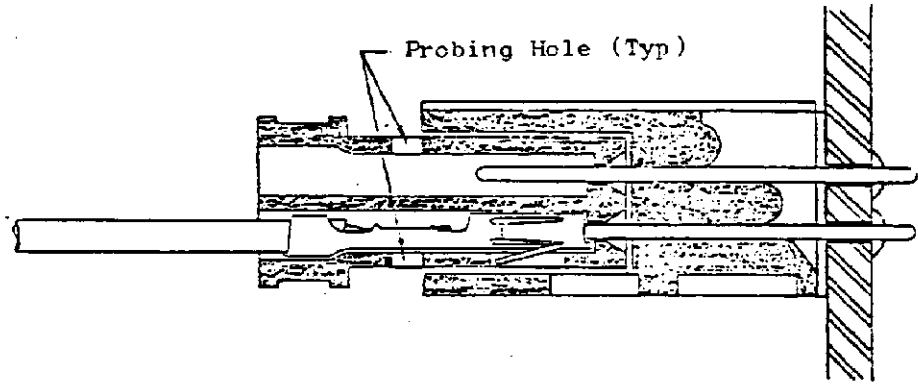

Fig. 3 Temperature Rising Testing

SHEET		AMP		AMP (Japan), Ltd. TOKYO, JAPAN	
10 OF 10		LOC J	A	NO 108-5134	REV E
NAME Product Specification AMP-MODU "J" Series Connector (Lever Lock Type)					