



TDK XIAMEN CO., LTD.  
 1~19 Lian sheng Road, Jimei  
 District, Xiamen, Fujian. (361021)  
 Phone : 086-0592-6150333-576 (634)

Branch Office \_\_\_\_\_

Sales div. Tel: \_\_\_\_\_

## SPECIFICATION APPROVAL

SPEC. No. XL-0911-2426 (00)

MESSRS : TCA/DISTRIBUTION

DATE : Jul. 12. '17

CUSTOMER'S PRODUCT NAME :

**PC44PQ32/30Z-12**

TDK PRODUCT NAME :

**PC44PQ32/30Z-12-NN**

THIS SPECIFICATION IS :

- FULLY APPROVED
- DENIED
- APPROVED UNDER THE FOLLOWING CONDITIONS

SIGNATURE : \_\_\_\_\_

DATE : \_\_\_\_\_

NAME (PRINTED) : \_\_\_\_\_

TITLE : \_\_\_\_\_

| MANUFACTURING. Magnetics Business Group |             |               | SALES DIV.  |               |
|---|-------------|---------------|-------------|---------------|
| PREPARED BY                             | APPROVED BY | AUTHORIZED BY | REVIEWED BY | AUTHORIZED BY |
|   |             |               |             |               |

## Basic contents

## 1 ). Scope of Application

This specification shall be applied for the Ferrite cores to be delivered to Messrs. TCA/DISTRIBUTION

## 2 ). Name of product

The name of the product to be defined in this specification shall be defined as PC44PQ32/30Z-12-NN

## 3 ). Related Specifications

## 4 ). Description

| Items                                  | Attached drawings and tables | Page |
|--|------------------------------|------|
| Outer appearance<br>structure and size |                              | 2    |
| Electrical<br>characteristics          |                              | 2    |
| Marking                                |                              | 2    |
| Manufacturing site                     |                              | 2    |
| Others                                 |                              | 3    |

## Revision Records

| Edition | Date      | Revised by  | Revision    |
|---------|-----------|-------------|-------------|
| 00      | 2017/7/12 | Huoyang Lin | First Issue |
|         |           |             |             |
|         |           |             |             |
|         |           |             |             |
|         |           |             |             |
|         |           |             |             |
|         |           |             |             |
|         |           |             |             |
|         |           |             |             |
|         |           |             |             |
|         |           |             |             |

Magnetics Business Group

Specification No.

**XL-0911-2426 (00)**

TDK CORPORATION

## 1. Dimensions (Unit : mm)

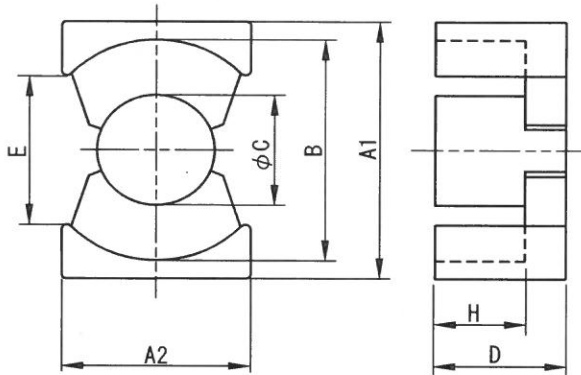

| sym | Dimensions  |
|-----|-------------|
| A1  | 32.0±0.50   |
| A2  | 22.0±0.50   |
| B   | 27.5±0.5    |
| φC  | 13.45±0.25  |
| D   | 15.17±0.125 |
| E   | 19.0 min.   |
| H   | 10.65±0.15  |

## 2. Electrical characteristics

| Item       | Specification         | Test conditions                     |
|------------|-----------------------|-------------------------------------|
| Inductance | 51.4 mH ± 25%         | ●EQUIP. : LCR METER (Agilent 4284A) |
|            |                       | or equivalent                       |
|            |                       | ●FREQ. : 1 kHz                      |
|            |                       | ●LEVEL : 0.5 mA                     |
| Core loss  | 3.92 W MAX. (at100°C) | ●EQUIP. : B-H ANALYZER              |
|            |                       | ●FREQ. : 100 kHz                    |
|            |                       | ●LEVEL : 200 mT                     |
|            |                       | ●COIL : N1=N2= 5 TS                 |

## 3. Marking

"PQ32 30 Lot-No. PC44 X Z" mark are marked with paint on the core's backside.

## 4. The core shall be supplied as pairs.

Example:

## 5. Manufacturing site

China: TDK Xiamen Co., Ltd

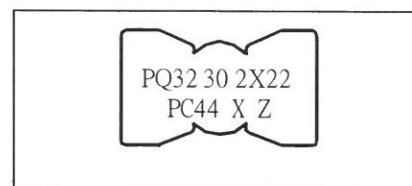

Specification No.

**XL-0911-2426 (00)**

**TDK CORPORATION**

## Inspection Test Schedule

Magnetics Business Group of TDK CORPORATION

performs outgoing inspection tests on the inspection items in Table-1.

The inspection shall be performed according to ISO-2859-1

Inspection level I (n=10, c=0 for dimension and n=5, c=0 for core loss)

Table-1. AQL and Inspection items

|   | AQL   | Inspection Items     |
|---|-------|----------------------|
| A | 0.4 % | Inductance and Crack |
| B | 1.0 % | Dimensions           |
| C | 1.5 % | Chipping             |

In principle the crack-core don't be allowed to use ;

But if the crack don't affect electrical characteristics and the customer agree with it , the product can be sent to customer.

Permissible limit of chips are prescribed as follows :

- (1) Depth of a permissible chip shall be 1.0 mm max. on mating faces and 1.2 mm max. on other faces. Chips on the corner should be judged by Table-2.
- (2) For the chips more than two on a core piece, the total area of chips shall be used as judgement.
- (3) Others.  
Not described above are based on IEC 60424 specification.

Table-2. Permissible limit of the area of chips.

|                    | Class |                          |
|--------------------|-------|--------------------------|
| Mating face        | 5     | ( 5 mm <sup>2</sup> )    |
| Except mating face | 10    | ( 10.0 mm <sup>2</sup> ) |

Specification No.

**XL-0911-2426 (00)**

**TDK CORPORATION**

**CAUTION !****CAUTIONS**

- Please seriously consider the following points in order to minimize heat generation:

- Select the material & shape of ferrite cores by utilizing the published nominal and min./max. values of magnetic properties especially;

- AL-value
- Saturation Flux Density (maximum)
- Core Loss
- Temperature Coefficients
- Frequency Characteristics
- Curie Temperature

- Provide proper insulation of windings by selecting non-corrosive and non-interacting materials and take care to avoid overfill of coilformer and scrapes or abrasions of wire insulation during winding.
- Insulation is further enhanced by use of a case, bobbin, tape, cement or other appropriate insulating medium with a thermal expansion coefficient very similar to that of ferrite.
- Avoid excessive force or poor fit of test fixtures and tools to prevent cracking or chipping the ferrite core.
- Provide clearance between the case, bobbin, coil and core to prevent cracking of the core and insulation breakdown.
- Distribute the coil windings evenly, preferably with Bi-Filar Windings, to prevent hot spots in the windings which could cause combustion.
- Keep safety in mind to prevent transient currents and to position the transformer assembly so that any heat generated in normal usage will not damage other circuit components even if another circuit should fail.
- To prevent personal injury when handling ferrite cores during assembly follow these precautions:

- Ferrites, a ceramic material, are fragile and can chip and crack when mishandled.
- Avoid placing ferrite cores near strong magnetic fields.
- Prevent mechanical shocking of cores when using fixtures or tools.
- Prevent thermal shocking of cores when may cause cracks.
- Polished cores have sharp mating edges. Avoid touching these surfaces.
- Because of the considerable weight of ferrite cores, be extra careful when stacking or handling cartons of cores.
- Avoid reprocessing ferrite cores.
- Ferrite cores are not edible. Make sure to keep ferrite cores away from young children so that they do not attempt to eat the cores.