

NOTES:

- FOR WAVESOLDERING (SOLDER BATH TEMPERATURE 265°C FOR 8 SEC. AND SOLDER PREHEAT 150°C FOR 180 SEC.)
- IP RATING: IP 67
- SEALED TO WITHSTAND PRESSURE UP TO 1,45 PSI FOR 30 MINUTES AFTER HIGH TEMPERATURE EXPOSURE
- METALSHELL:
ZINC DIE CAST; min. 50µin NICKEL PLATING over COPPER
- INSULATORS: PBT GF UL 94 V-0, BLACK
- O-RING: SILICONE PER ASTM D2000 70 SHORE A
- SEALING COMPOUND: EPOXY RESIN UL 94 V-0; BLACK
- CONTACTS: COPPER ALLOY
PLATING (SEE PART NO):
 PLEASE ADD 1 for 30µin HARD GOLD over min. 50µin NICKEL
 PLEASE ADD 3 for 8µin HARD GOLD over min. 50µin NICKEL
- METAL BRACKETS: ZINC DIE CAST;
300µin COPPER/40-120µin NICKEL/120-200µin TIN
- WASHERS: COPPER ALLOY; 80µin NICKEL
- HEXLOCKING SCREWS: STAINLESS STEEL
- PCB-SNAPS: COPPER ALLOY; min. 200µin TIN over 80µin NICKEL
PCB-HOLE: $\varnothing 3.1 \pm 0.1$; PCB THICKNESS 1.6mm
- P.C.B. HOLE DRILLINGS and RECOMMENDED PANEL CUT-OUT ON SHEET 2
- RECOMMENDED TORQUE FOR MOUNTING SCREW
35Ncm (3.1 in.LB) / max.67Ncm (6 in.LB)
- CONNECTOR IS PART MARKED: 15-00087 CONEC ABC

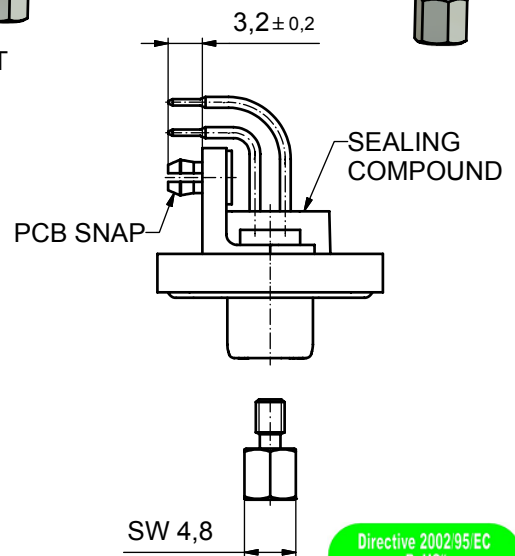

AT ALL TIMES WATER RESISTANT CONNECTORS NOT IN USE SHOULD BE COVERED WITH A CONEC WATER RESISTANT CAP OR WATER TIGHT HOOD.

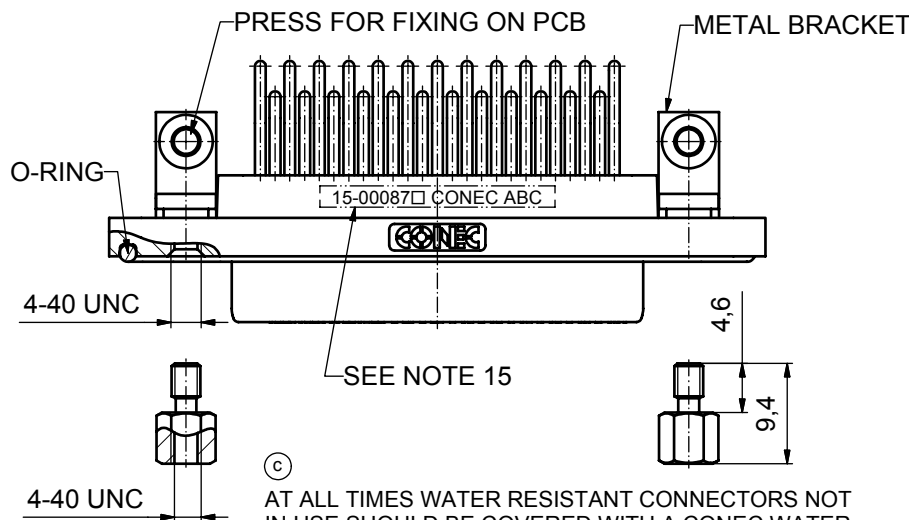
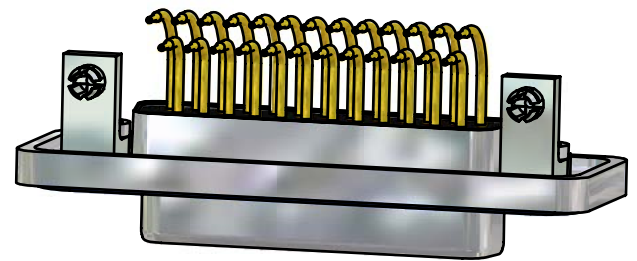
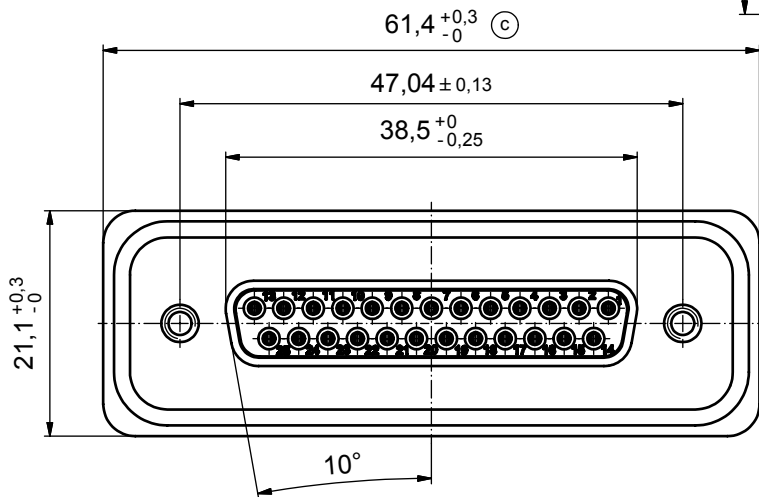
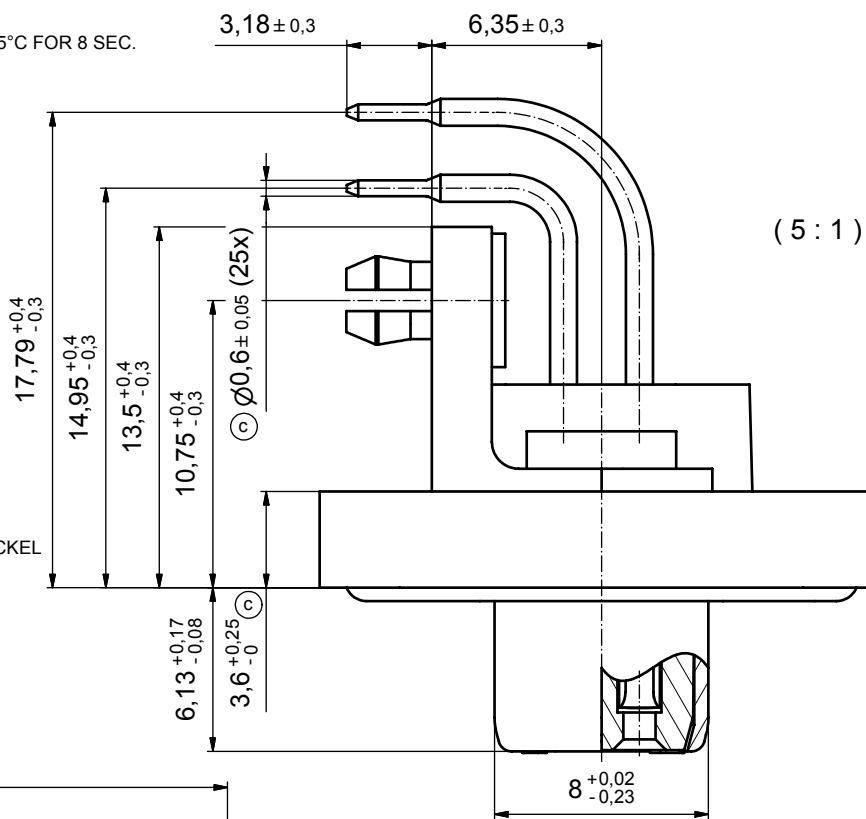

APPROVAL # FREIGABE # DEBLOCAGE # AUTORIZACION # APPROVAL	
CUSTOMER APPROVAL DATE:	
NAME:	TITLE:
COMPANY NAME:	
APPROVAL # FREIGABE # DEBLOCAGE # AUTORIZACION # APPROVAL	

THIS DRAWING MAY NOT BE COPIED OR REPRODUCED IN ANY WAY, AND MAY NOT BE PASSED ON TO A THIRD PARTY WITHOUT WRITTEN PERMISSION. OWNERSHIP AND COPYRIGHT OF CONEC GmbH				tolerance		dim. in mm	
DO NOT ALTER CAD DRAWING BY HAND				date	name		
4 x c	A 3435	09.10.09	HS	drawn	17.10.08	Schmidt	
a	Origin			appd.	23.10.08	Fischer	
rev.	description	date	name	norm			
				d-old			
				CONEC			

scale:	2:1 (5:1)		
material:	see notes		
title:			
D-SUB FEMALE 90° 25pos. SOLDER PIN ANGLED with metal bracket, hexlocking screw and snap			
dwg no:	Inventor 10	DIN-A3	
	15K1A302	sh: 1	
part no:	15-00087 (see note 8)		

P.C.B. HOLE DRILLINGS

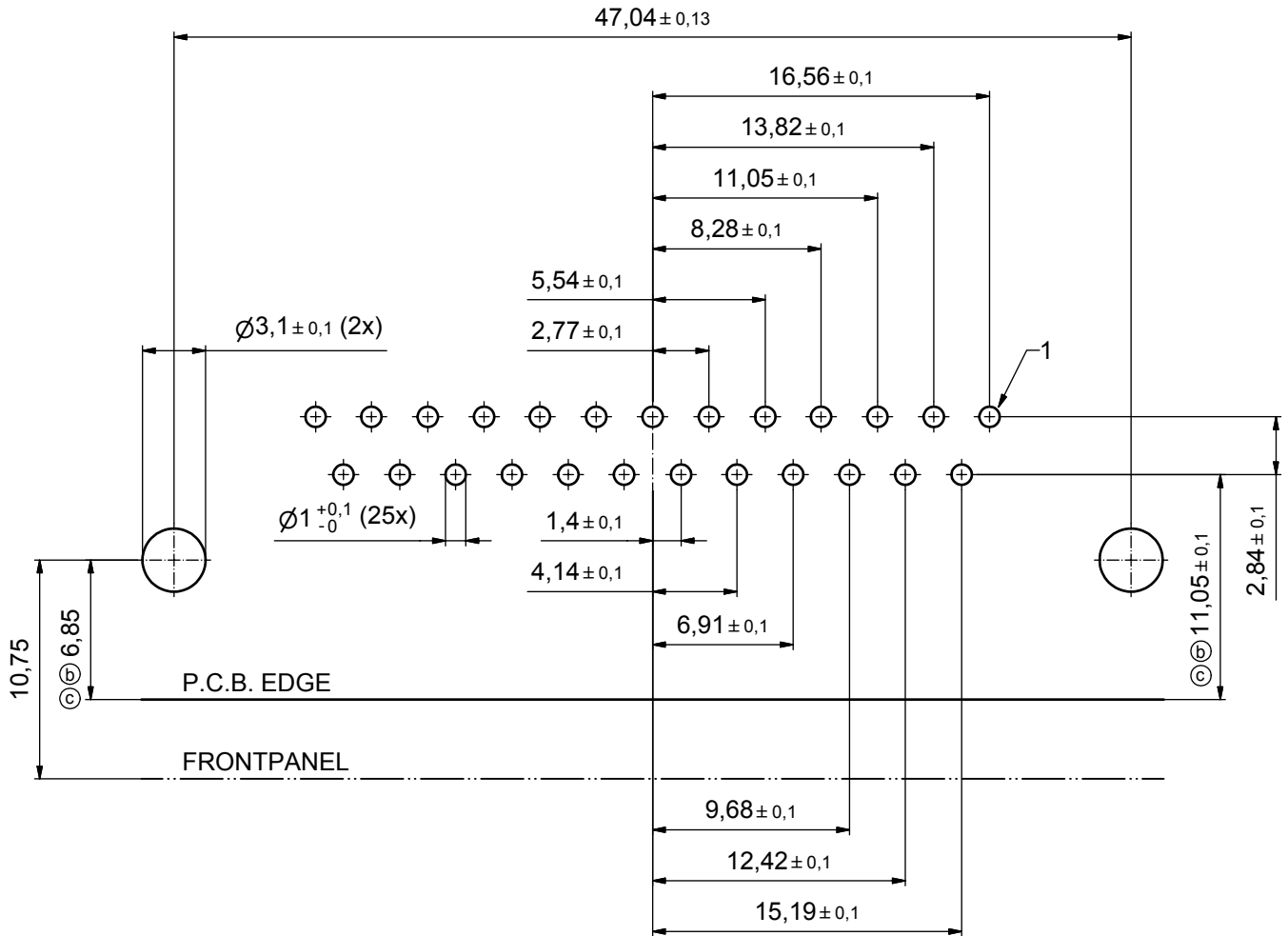

RECOMMENDED PANEL CUT-OUT

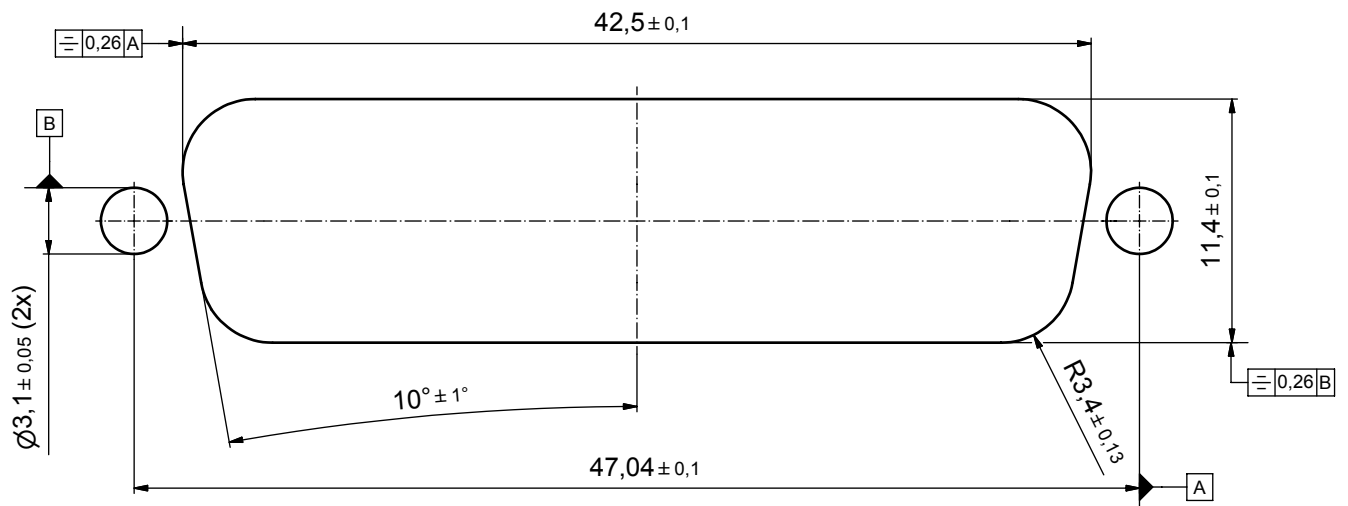

APPROVAL # FREIGABE # DEBLOCAGE # AUTORIZACION # APPROVAL	
CUSTOMER APPROVAL DATE:	
NAME:	TITLE:
COMPANY NAME:	
APPROVAL # FREIGABE # DEBLOCAGE # AUTORIZACION # APPROVAL	

THIS DRAWING MAY NOT BE COPIED OR REPRODUCED IN ANY WAY, AND MAY NOT BE PASSED ON TO A THIRD PARTY WITHOUT WRITTEN PERMISSION. OWNERSHIP AND COPYRIGHT OF CONEC GmbH				tolerance		dim. in mm	
DO NOT ALTER CAD DRAWING BY HAND				date	name	scale: 4:1	
2 x c	A 3435	09.10.09	HS	drawn	17.10.08	Schmidt	material: see sheet 1
2 x b	A 3344	15.04.09	HS	appd.	23.10.08	Fischer	title: P.C.B HOLE DRILLINGS PANEL CUT-OUT D-SUB Female 25pos. Solder pin angled
a	Origin			norm			dwg no: Inventor 10
rev.	description	date	name	CONEC			DIN-A3

scale: 4:1	
material: see sheet 1	
title: P.C.B HOLE DRILLINGS PANEL CUT-OUT D-SUB Female 25pos. Solder pin angled	
dwg no: Inventor 10	DIN-A3
15K1A302	
part no: see sheet 1	sh: 2