

TDA8942P

2 x 1.5 W (3 W music power) stereo Bridge Tied Load (BTL) audio amplifier

Rev. 03 — 02 September 2003

Product data

1. General description

The TDA8942P is a dual-channel audio power amplifier for an output power of 2×1.5 W at a 16Ω load and a 9 V supply. The amplifier is even capable of delivering 2×3 W music power at an 8Ω load. The circuit contains two Bridge Tied Load (BTL) amplifiers with an all-NPN output stage and standby/mute logic. The TDA8942P comes in a 16-pin dual in-line (DIP) package. The TDA8942P is printed-circuit board (PCB) compatible with all other types in the TDA894x family. One PCB footprint accommodates both the mono and the stereo products.

2. Features

- Few external components
- Fixed gain
- Standby and mute mode
- No on/off switching plops
- Low standby current
- High supply voltage ripple rejection
- Outputs short-circuit protected to ground, supply and across the load
- Thermally protected
- Printed-circuit board compatible
- Output power up to 2×3 W music power (limited by thermal resistance).

3. Applications

- Mains fed applications (e.g. TV sound)
- PC audio
- Portable audio.



PHILIPS

4. Quick reference data

Table 1: Quick reference data

Symbol	Parameter	Conditions	Min	Typ	Max	Unit
V_{CC}	supply voltage		6	9	18	V
I_q	quiescent supply current	$V_{CC} = 12\text{ V}; R_L = \infty$	-	22	32	mA
I_{stb}	standby supply current		-	-	10	μA
P_o	output power	THD = 10 %; $V_{CC} = 9\text{ V}$ $R_L = 16\ \Omega$ $R_L = 8\ \Omega$	1.2 [1] -	1.5 3	- -	W W
THD	total harmonic distortion	$P_o = 0.5\text{ W}$	-	0.03	0.3	%
G_v	voltage gain		31	32	33	dB
SVRR	supply voltage ripple rejection		50	65	-	dB

[1] Measured on 1 channel simultaneously.

5. Ordering information

Table 2: Ordering information

Type number	Package		
	Name	Description	Version
TDA8942P	DIP16	plastic dual in-line package; 16 leads (300 mil); long body	SOT38-1

6. Block diagram

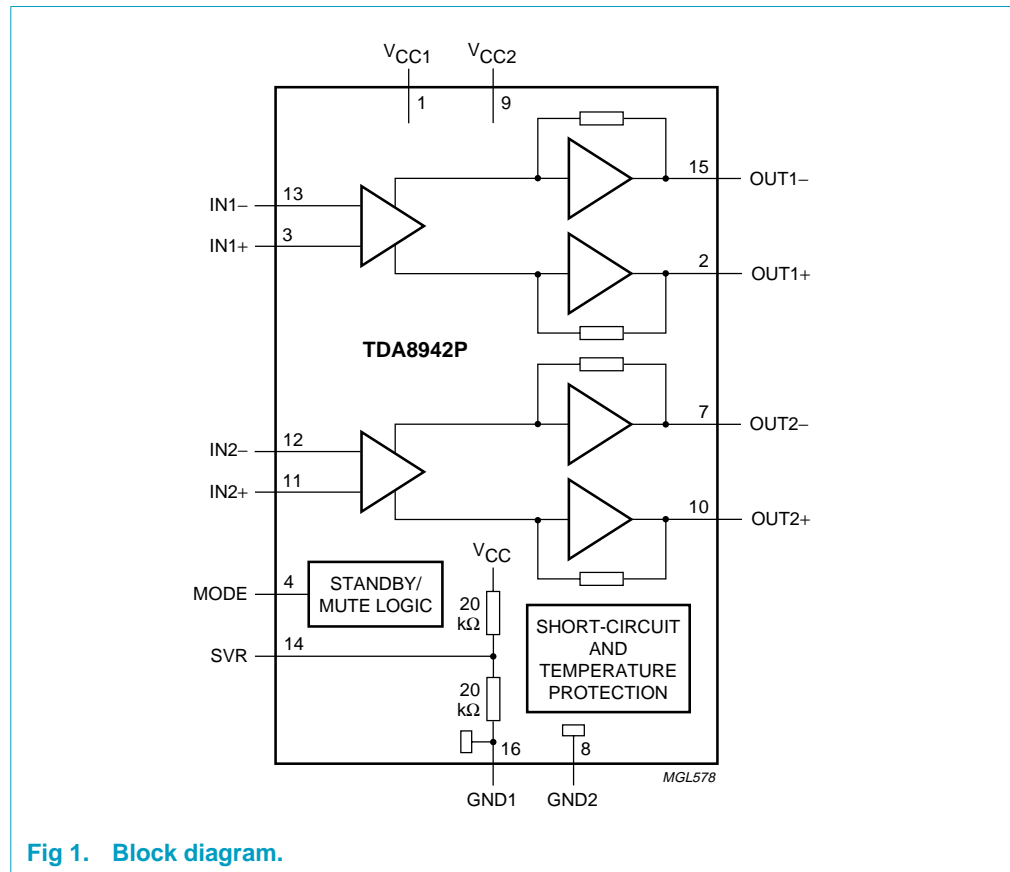

Fig 1. Block diagram.

7. Pinning information

7.1 Pinning

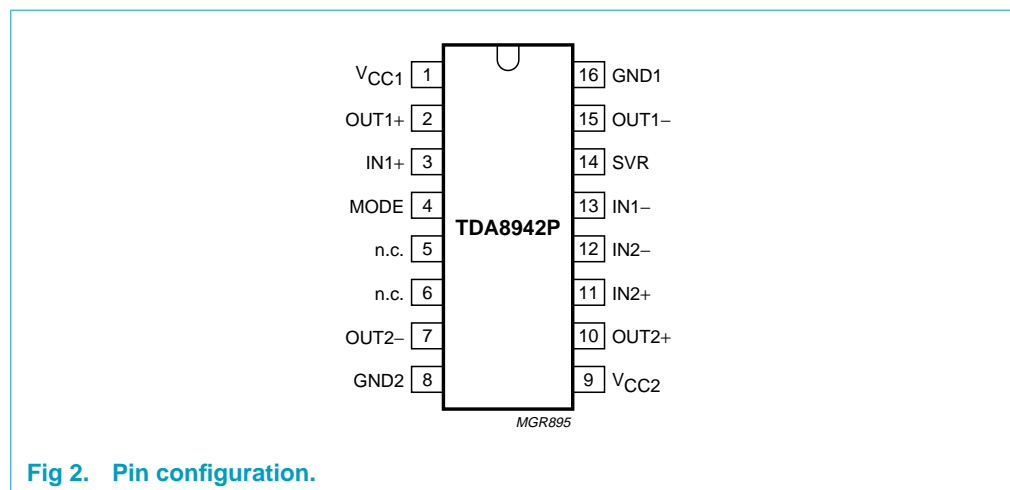

Fig 2. Pin configuration.

7.2 Pin description

Table 3: Pin description

Symbol	Pin	Description
V _{CC1}	1	supply voltage channel 1
OUT1+	2	positive loudspeaker terminal 1
IN1+	3	positive input 1
MODE	4	mode selection input (standby, mute, operating)
n.c.	5	not connected
n.c.	6	not connected
OUT2-	7	negative loudspeaker terminal 2
GND2	8	ground channel 2
V _{CC2}	9	supply voltage channel 2
OUT2+	10	positive loudspeaker terminal 2
IN2+	11	positive input 2
IN2-	12	negative input 2
IN1-	13	negative input 1
SVR	14	half supply voltage decoupling (ripple rejection)
OUT1-	15	negative loudspeaker terminal 1
GND1	16	ground channel 1

8. Functional description

The TDA8942P is a stereo BTL audio power amplifier capable of delivering 2×1.5 W output power to a 16Ω load at THD = 10 %, using a 9 V power supply. The voltage gain is fixed at 32 dB.

With the three-level MODE input the device can be switched from standby to mute and to operating mode.

The TDA8942P outputs are protected by an internal thermal shutdown protection mechanism and a short-circuit protection.

8.1 Input configuration

The TDA8942P inputs can be driven symmetrical (floating) as well as asymmetrical. In the asymmetrical mode one input pin is connected via a capacitor to the signal ground which should be as close as possible to the SVR (electrolytic) capacitor ground. Note that the DC level of the input pins is half of the supply voltage V_{CC} , so coupling capacitors for both pins are necessary.

The input cut-off frequency is:

$$f_{i(cut-off)} = \frac{1}{2\pi(R_i \times C_i)} \quad (1)$$

For $R_i = 45 \text{ k}\Omega$ and $C_i = 220 \text{ nF}$:

$$f_{i(cut-off)} = \frac{1}{2\pi(45 \times 10^3 \times 220 \times 10^{-9})} = 16 \text{ Hz} \quad (2)$$

As shown in [Equation 1](#) and [Equation 2](#), large capacitor values for the inputs are not necessary; so the switch-on delay during charging of the input capacitors can be minimized. This results in a good low frequency response and good switch-on behavior.

Remark: To prevent HF oscillations do not leave the inputs open: connect a capacitor of at least 1.5 nF across the input pins close to the device.

8.2 Power amplifier

The power amplifier is a BTL amplifier with an all-NPN output stage, capable of delivering a peak output current of 2 A.

The BTL principle offers the following advantages:

- Lower peak value of the supply current
- Ripple frequency on the supply voltage is twice the signal frequency
- No expensive DC-blocking capacitor
- Good low frequency performance.

8.2.1 Output power measurement

The output power as a function of the supply voltage is measured on the output pins at THD = 10 %; see [Figure 8](#). The maximum output power is limited by the maximum power dissipation in the plastic dual in-line (DIP16) package. See also [Section 14.3](#).

8.2.2 Headroom

Typical CD music requires at least 12 dB (factor 15.85) dynamic headroom – compared to the average power output – for transferring the loudest parts without distortion. At $V_{CC} = 9\text{ V}$, $R_L = 16\ \Omega$ and $P_o = 1\text{ W}$ at THD = 1 % (see [Figure 6a](#)), the Average Listening Level (ALL) – music power – without any distortion yields:

$$P_{o(\text{ALL})} = 1\text{ W}/15.85 = 63\text{ mW}.$$

The power dissipation can be derived from [Figure 11](#) for 0 dB respectively 12 dB headroom.

For the average listening level a power dissipation of 1.15 W can be used for calculation of the maximum ambient temperature $T_{\text{amb}(\text{max})}$ (see [Section 14.3](#)).

[Table 4](#) shows the power rating as a function of headroom for peak music power into 2 channels for both 1 W and 3 W.

Table 4: Power rating as function of headroom

Headroom	Power output (THD = 1 %)	Power dissipation (P)
1 W peak music power		
0 dB	$P_o = 1\text{ W}$	2.35 W
12 dB	$P_{o(\text{ALL})} = 63\text{ mW}$	1.15 W
3 W peak music power		
0 dB	$P_o = 3\text{ W}$	4.3 W
12 dB	$P_{o(\text{ALL})} = 189\text{ mW}$	2.17 W

8.3 Mode selection

The TDA8942P has three functional modes, which can be selected by applying the proper DC voltage to pin MODE. See [Figure 4](#) and [Figure 5](#) for the respective DC levels, which depend on the supply voltage level. The MODE pin can be driven by a 3-state logic output stage e.g. a microcontroller with additional components for DC-level shifting.

Standby — In this mode the current consumption is very low and the outputs are floating. The device is in standby mode when $(V_{CC} - 0.5 \text{ V}) < V_{MODE} < V_{CC}$, or when the MODE pin is left floating (high impedance). The power consumption of the TDA8942P will be reduced to $< 0.18 \text{ mW}$.

Mute — In this mode the amplifier is DC-biased but not operational (no audio output); the DC level of the input and output pins remain on half the supply voltage. This allows the input coupling and Supply Voltage Ripple Rejection (SVRR) capacitors to be charged to avoid pop-noise. The device is in mute mode when $3 \text{ V} < V_{MODE} < (V_{CC} - 1.5 \text{ V})$.

Operating — In this mode the amplifier is operating normally. The operating mode is activated at $V_{MODE} < 0.5 \text{ V}$.

8.3.1 Switch-on and switch-off

To avoid audible plops during supply voltage switch-on or switch-off, the device is set to standby mode before the supply voltage is applied (switch-on) or removed (switch-off).

The switch-on and switch-off time can be influenced by an RC-circuit on the MODE pin. Rapid on/off switching of the device or the MODE pin may cause 'click- and pop-noise'. This can be prevented by proper timing of the RC-circuit on the MODE pin.

8.4 Supply voltage ripple rejection

The supply voltage ripple rejection (SVRR) is measured with an electrolytic capacitor of $10 \mu\text{F}$ on pin SVR at a bandwidth of 10 Hz to 80 kHz. Figure 13 illustrates the SVRR as function of the frequency. A larger capacitor value on the SVR pin improves the ripple rejection behavior at the lower frequencies.

8.5 Built-in protection circuits

The TDA8942P contains two types of protection circuits, i.e. short-circuit and thermal shutdown.

8.5.1 Short-circuit protection

Short-circuit to ground or supply line — This is detected by a so-called 'missing current' detection circuit which measures the current in the positive supply line and the current in the ground line. A difference between both currents larger than 0.4 A, switches the power stage to standby mode (high impedance).

Short-circuit across the load — This is detected by an absolute-current measurement. An absolute-current larger than 2 A, switches the power stage to standby mode (high impedance).

8.5.2 Thermal shutdown protection

The junction temperature is measured by a temperature sensor; at a junction temperature of approximately $150 \text{ }^\circ\text{C}$ this detection circuit switches the power stage to standby mode (high impedance).

9. Limiting values

Table 5: Limiting values

In accordance with the Absolute Maximum Rating System (IEC 60134).

Symbol	Parameter	Conditions	Min	Max	Unit
V_{CC}	supply voltage	no signal	-0.3	+25	V
		operating	-0.3	+18	V
V_I	input voltage		-0.3	$V_{CC} + 0.3$	V
I_{ORM}	repetitive peak output current		-	2	A
T_{stg}	storage temperature	non-operating	-55	+150	°C
T_{amb}	ambient temperature		-40	+85	°C
P_{tot}	total power dissipation		-	2.2	W
$V_{CC(sc)}$	supply voltage to guarantee short-circuit protection		-	12	V

10. Thermal characteristics

Table 6: Thermal characteristics

Symbol	Parameter	Conditions	Value	Unit
$R_{th(j-a)}$	thermal resistance from junction to ambient	in free air	57	K/W

11. Static characteristics

Table 7: Static characteristics

$V_{CC} = 9\text{ V}$; $T_{amb} = 25\text{ °C}$; $R_L = 8\ \Omega$; $V_{MODE} = 0\text{ V}$; $V_I = 0\text{ V}$; measured in test circuit *Figure 14*; unless otherwise specified.

Symbol	Parameter	Conditions	Min	Typ	Max	Unit
V_{CC}	supply voltage	operating	6	9	18	V
I_q	quiescent supply current	$R_L = \infty$	[1] -	22	32	mA
I_{stb}	standby supply current	$V_{MODE} = V_{CC}$	-	-	10	μA
V_O	DC output voltage		[2] -	4.5	-	V
ΔV_{OUT}	differential output voltage offset		[3] -	-	200	mV
V_{MODE}	mode selection input voltage	operating mode	0	-	0.5	V
		mute mode	3	-	$V_{CC} - 1.5$	V
		standby mode	$V_{CC} - 0.5$	-	V_{CC}	V
I_{MODE}	mode selection input current	$0 < V_{MODE} < V_{CC}$	-	-	20	μA

[1] With a load connected at the outputs the quiescent current will increase, the maximum of this increase being equal to the differential output voltage offset (ΔV_{OUT}) divided by the load resistance (R_L).

[2] The DC output voltage with respect to ground is approximately $0.5V_{CC}$.

[3] $\Delta V_{OUT} = |V_{OUT+} - V_{OUT-}|$

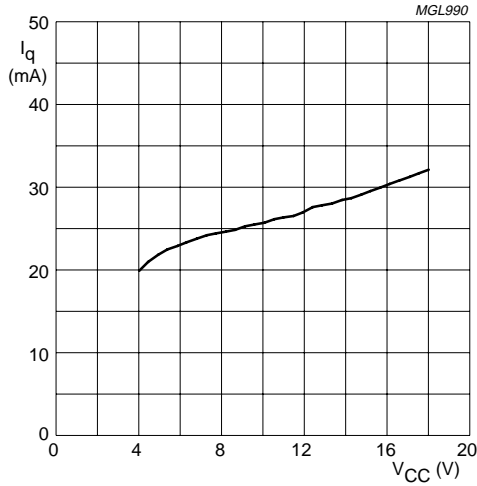

Fig 3. Quiescent supply current as function of supply voltage.

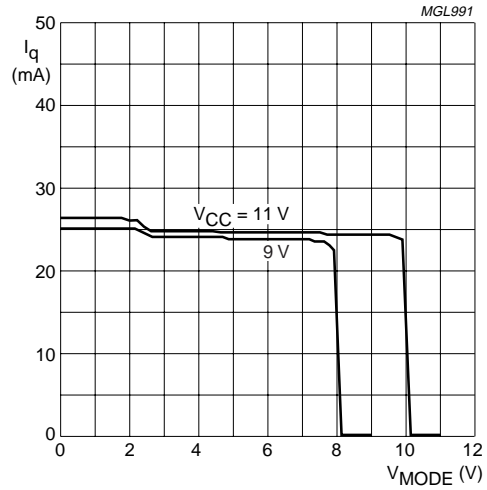

Fig 4. Quiescent supply current as function of mode selection voltage.

12. Dynamic characteristics

Table 8: Dynamic characteristics

$V_{CC} = 9\text{ V}$; $T_{amb} = 25\text{ }^\circ\text{C}$; $R_L = 8\ \Omega$; $f = 1\text{ kHz}$; $V_{MODE} = 0\text{ V}$; measured in test circuit *Figure 14*; audio pass band 22 Hz to 22 kHz; unless otherwise specified.

Symbol	Parameter	Conditions	Min	Typ	Max	Unit
P _o	output power	THD = 10 %; R _L = 16 Ω	1.2	1.5	-	W
		THD = 10 %; R _L = 8 Ω	[1] -	3	-	W
		THD = 0.5 %; R _L = 8 Ω	0.8	1	-	W
THD	total harmonic distortion	P _o = 0.5 W	-	0.03	0.3	%
G _v	voltage gain		31	32	33	dB
Z _{i(dif)}	differential input impedance		70	90	110	kΩ
V _{n(o)}	noise output voltage		[2] -	90	120	μV
SVRR	supply voltage ripple rejection	f _{ripple} = 1 kHz	[3] 50	65	-	dB
		f _{ripple} = 100 Hz to 20 kHz	[3] -	60	-	dB
V _{o(mute)}	output voltage in mute mode		[4] -	-	50	μV
α _{cs}	channel separation	R _S = 0 Ω	50	75	-	dB

- [1] Measured on 1 channel simultaneously.
- [2] The noise output voltage is measured at the output in a frequency range from 20 Hz to 20 kHz (unweighted), with a source impedance R_S = 0 Ω at the input.
- [3] Supply voltage ripple rejection is measured at the output, with a source impedance R_S = 0 Ω at the input. The ripple voltage is a sine wave with a frequency f_{ripple} and an amplitude of 700 mV (RMS), which is applied to the positive supply rail.
- [4] Output voltage in mute mode is measured with an input voltage of 1 V (RMS) in a bandwidth of 20 kHz, so including noise.

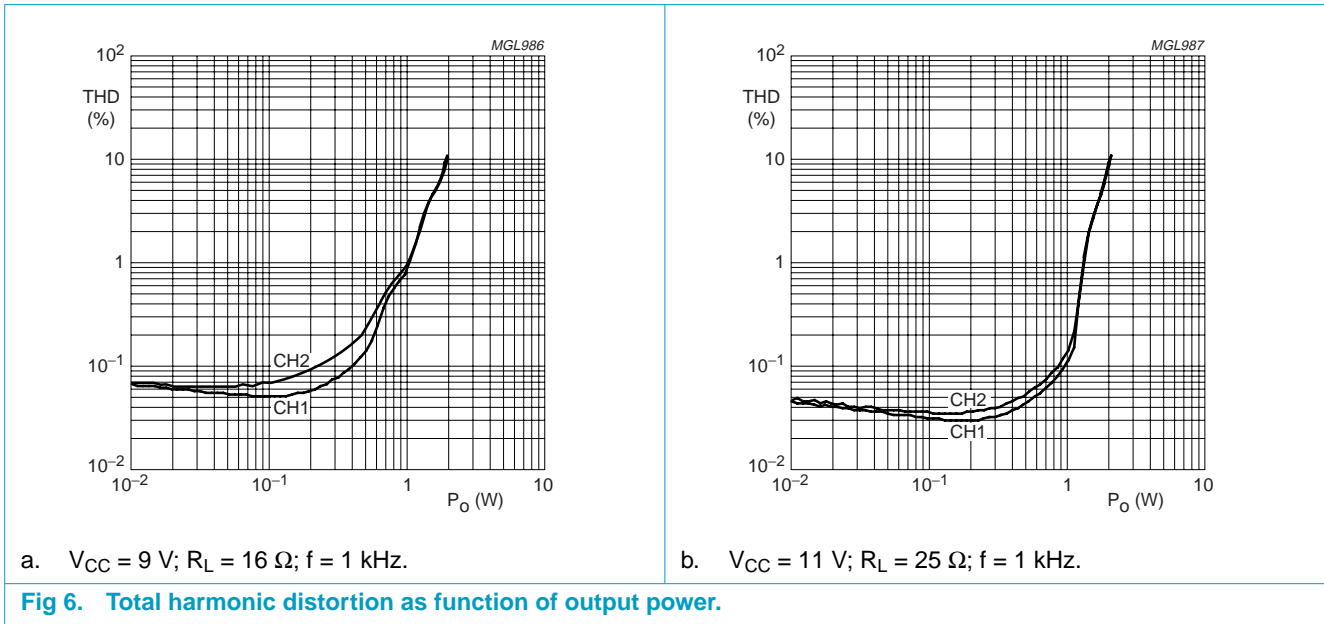
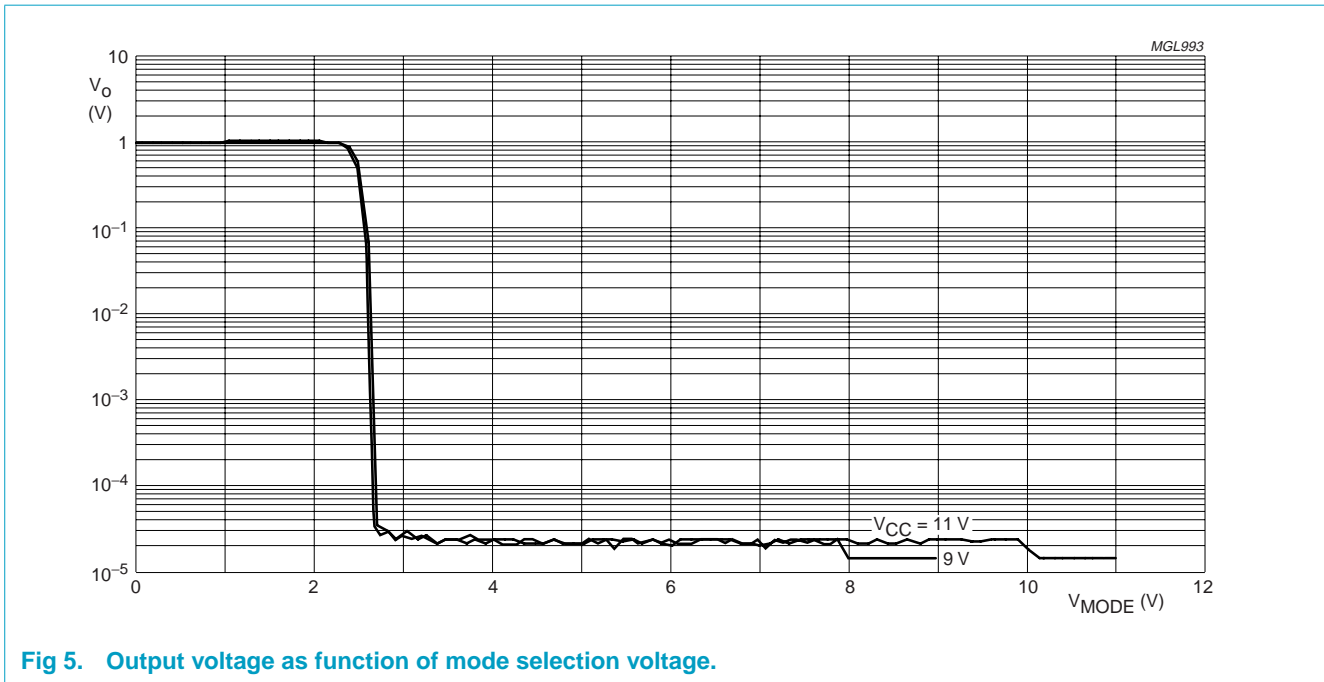

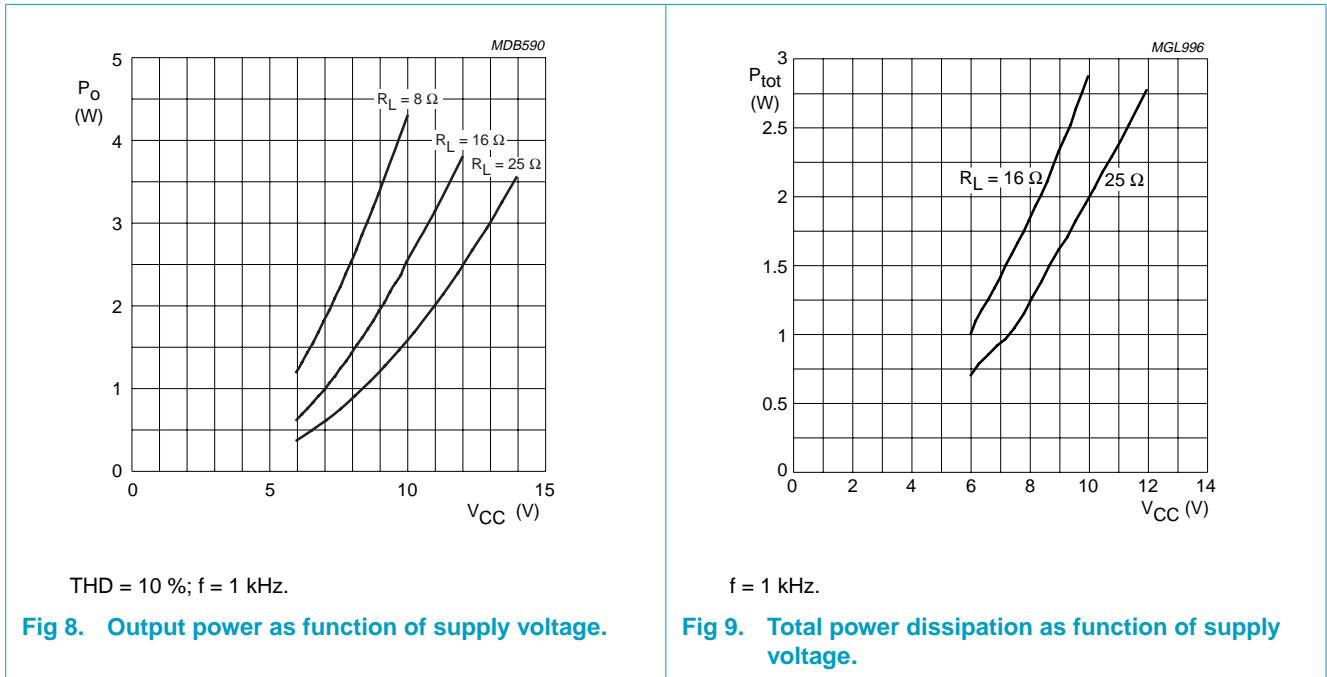
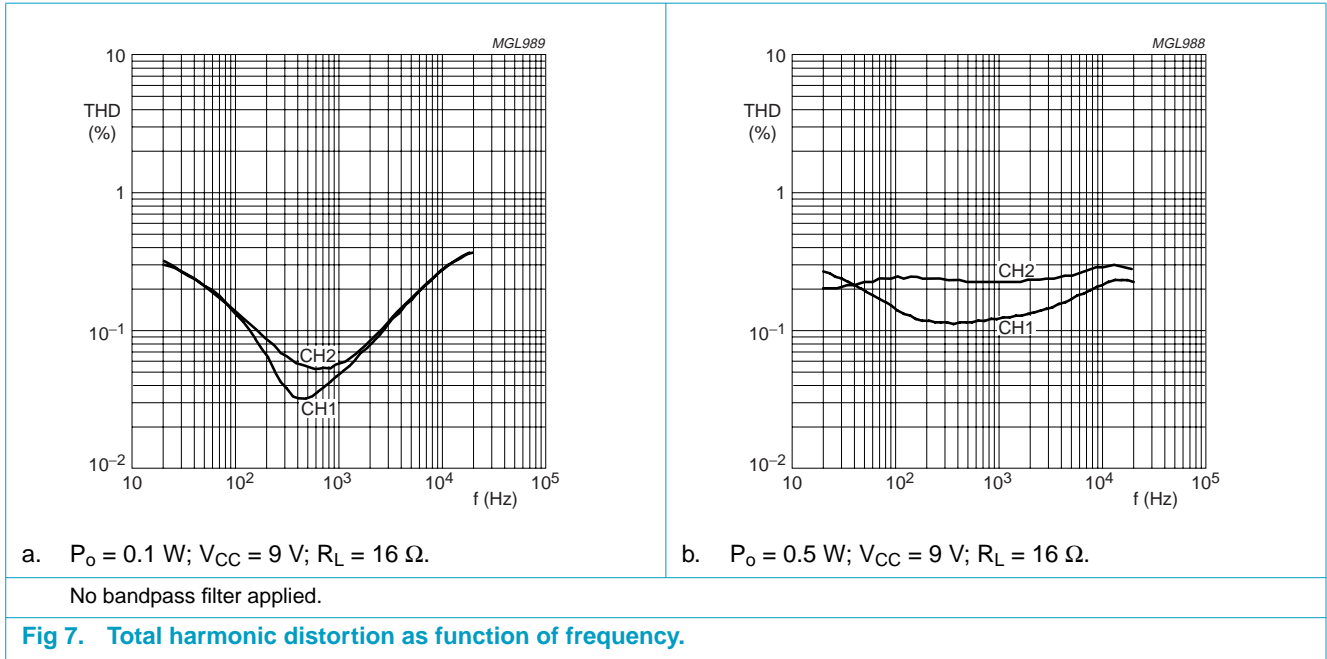

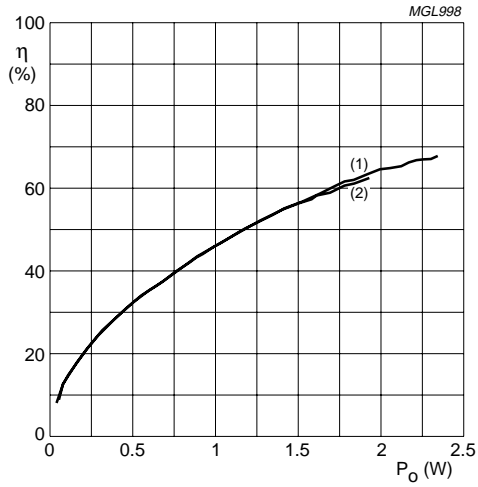

- (1) $V_{CC} = 9$ V.
- (2) $V_{CC} = 11$ V.

Fig 10. Efficiency as function of output power.

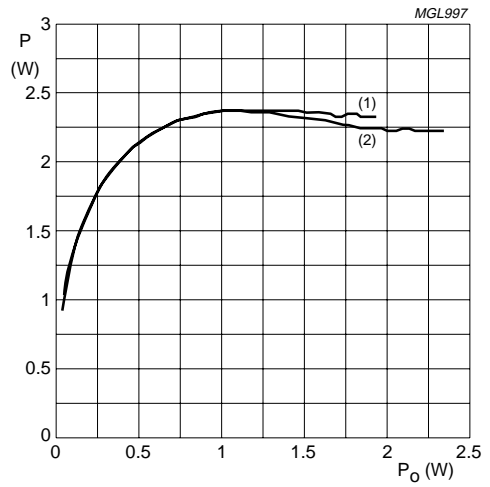

- (1) $V_{CC} = 9$ V; $R_L = 16$ Ω.
- (2) $V_{CC} = 11$ V; $R_L = 25$ Ω.

Fig 11. Power dissipation as function of output power.

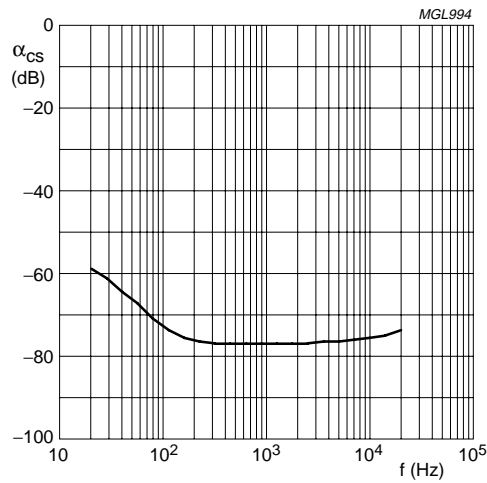

No bandpass filter applied.

Fig 12. Channel separation as function of frequency.

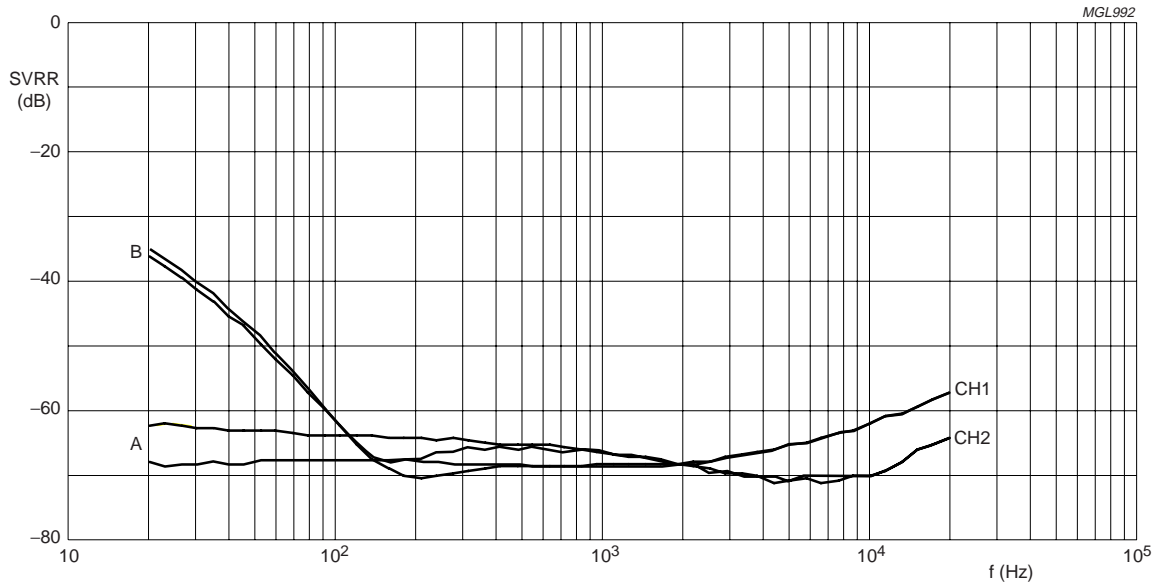

$V_{CC} = 9\text{ V}$; $R_S = 0\ \Omega$; $V_{\text{ripple}} = 700\text{ mV (RMS)}$; no bandpass filter applied.

Curves A: inputs short-circuited.

Curves B: inputs short-circuited and connected to ground (asymmetrical application).

Fig 13. Supply voltage ripple rejection as function of frequency.

13. Internal circuitry

Table 9: Internal circuitry

Pin	Symbol	Equivalent circuit
3 and 13	IN1+ and IN1-	
11 and 12	IN2+ and IN2-	
15 and 2	OUT1- and OUT1+	
7 and 10	OUT2- and OUT2+	
4	MODE	
14	SVR	

14. Application information

14.1 Application diagram

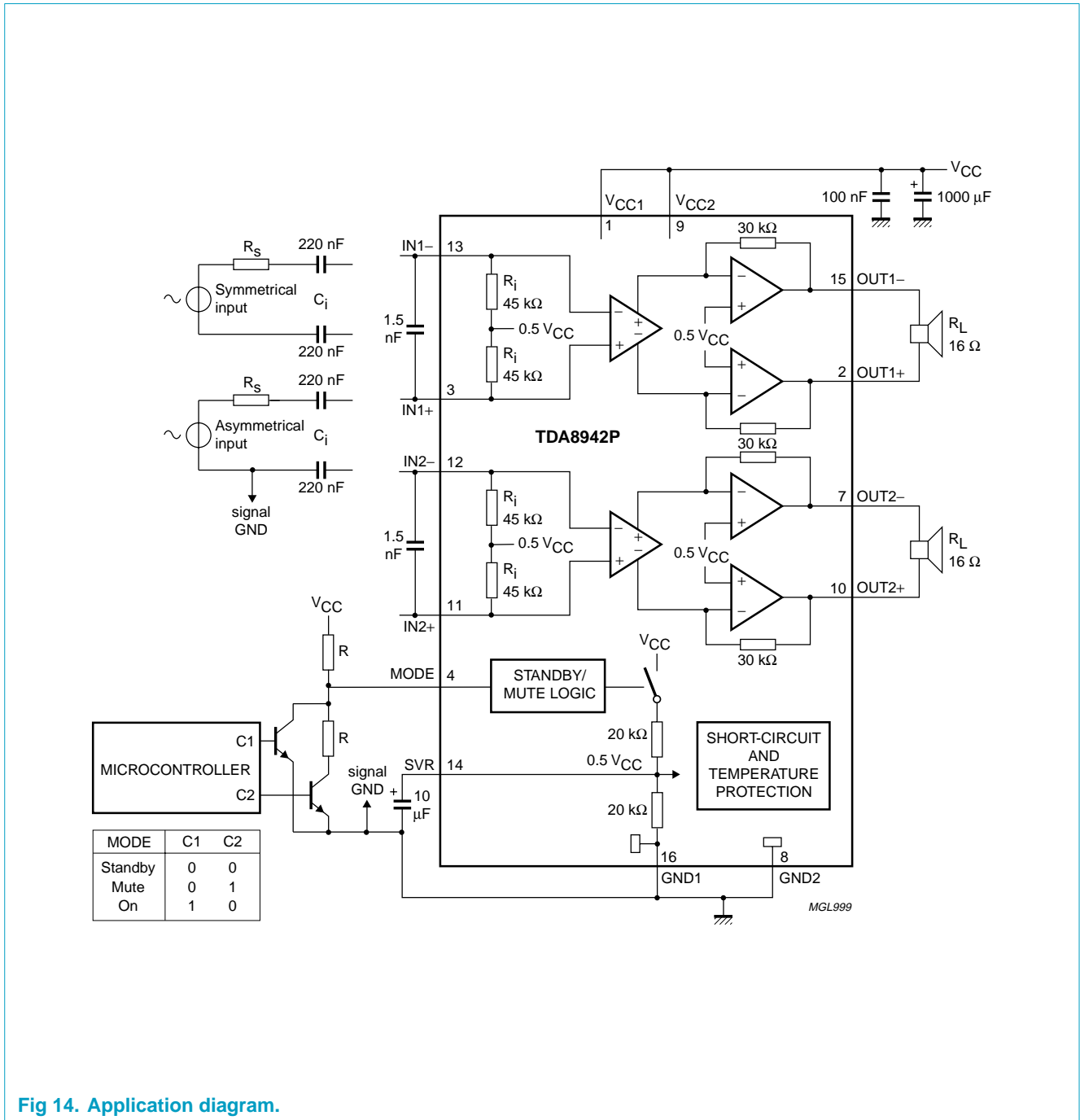

Fig 14. Application diagram.

14.2 Printed-circuit board

14.2.1 Layout and grounding

For a high system performance level certain grounding techniques are essential. The input reference grounds have to be tied with their respective source grounds and must have separate tracks from the power ground tracks; this will prevent the large (output) signal currents from interfering with the small AC input signals. The small-signal ground tracks should be physically located as far as possible from the power ground tracks. Supply and output tracks should be as wide as possible for delivering maximum output power.

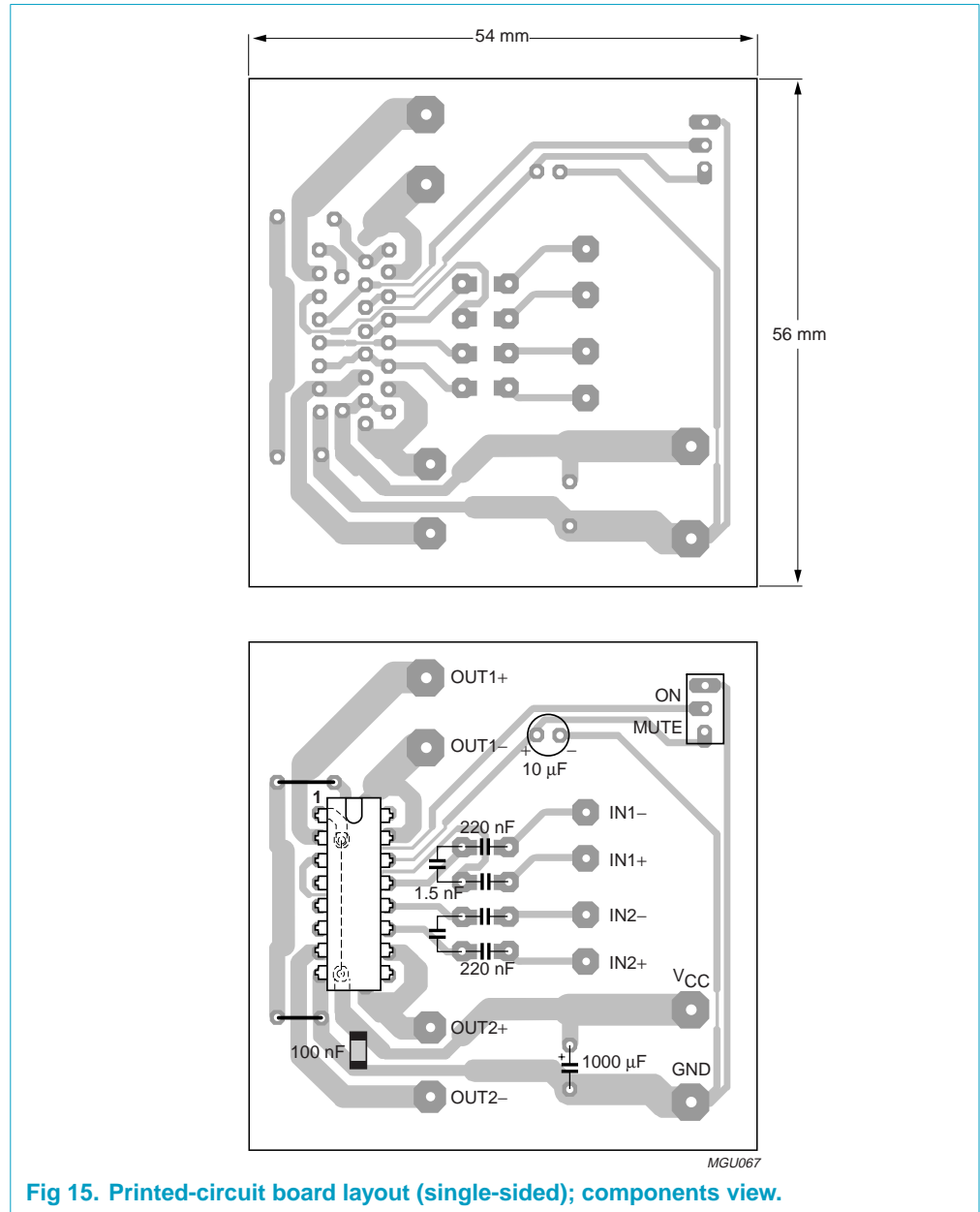

Fig 15. Printed-circuit board layout (single-sided); components view.

14.2.2 Power supply decoupling

Proper supply bypassing is critical for low-noise performance and high supply voltage ripple rejection. The respective capacitor locations should be as close as possible to the device and grounded to the power ground. Proper power supply decoupling also prevents oscillations.

For suppressing higher frequency transients (spikes) on the supply line a capacitor with low ESR – typical 100 nF – has to be placed as close as possible to the device. For suppressing lower frequency noise and ripple signals, a large electrolytic capacitor – e.g. 1000 μ F or greater – must be placed close to the device.

The bypass capacitor on the SVR pin reduces the noise and ripple on the mid rail voltage. For good THD and noise performance a low ESR capacitor is recommended.

14.3 Thermal behavior and $T_{\text{amb(max)}}$ calculation

The measured maximum thermal resistance of the IC package, $R_{\text{th(j-a)}}$ is 57 K/W. A calculation for the maximum ambient temperature can be made, with the following parameters:

$$V_{\text{CC}} = 9 \text{ V and } R_{\text{L}} = 16 \ \Omega$$

$$T_{\text{j(max)}} = 150 \text{ }^\circ\text{C}$$

$R_{\text{th(tot)}}$ is the total thermal resistance between the junction and the ambient.

At $V_{\text{CC}} = 9 \text{ V}$ and $R_{\text{L}} = 16 \ \Omega$ the measured worst-case sine-wave dissipation is 2.35 W; see [Figure 11](#). For $T_{\text{j(max)}} = 150 \text{ }^\circ\text{C}$ the maximum ambient temperature is:

$$T_{\text{amb(max)}} = 150 - 2.35 \times 57 = 16 \text{ }^\circ\text{C}$$

The calculation above is for an application at worst-case (stereo) sine-wave output signals. In practice music signals will be applied, which decreases the maximum power dissipation to approximately half of the sine-wave power dissipation (see [Section 8.2.2](#)). For $T_{\text{j(max)}} = 150 \text{ }^\circ\text{C}$ the maximum ambient temperature is:

$$T_{\text{amb(max)}} = 150 - 1.15 \times 57 = 84.5 \text{ }^\circ\text{C}$$

To increase the lifetime of the IC, $T_{\text{j(max)}}$ should be reduced to 125 $^\circ\text{C}$. This results in:

$$T_{\text{amb(max)}} = 125 - 1.15 \times 57 = 59.5 \text{ }^\circ\text{C}$$

15. Test information

15.1 Quality information

The *General Quality Specification for Integrated Circuits, SNW-FQ-611* is applicable.

15.2 Test conditions

$T_{\text{amb}} = 25 \text{ }^\circ\text{C}$; $V_{\text{CC}} = 9 \text{ V}$; $f = 1 \text{ kHz}$; $R_{\text{L}} = 16 \ \Omega$; audio pass band 22 Hz to 22 kHz; unless otherwise specified. In the graphs as function of frequency no bandpass filter was applied; see [Figure 7](#), [12](#) and [13](#).

16. Package outline

DIP16: plastic dual in-line package; 16 leads (300 mil); long body

SOT38-1

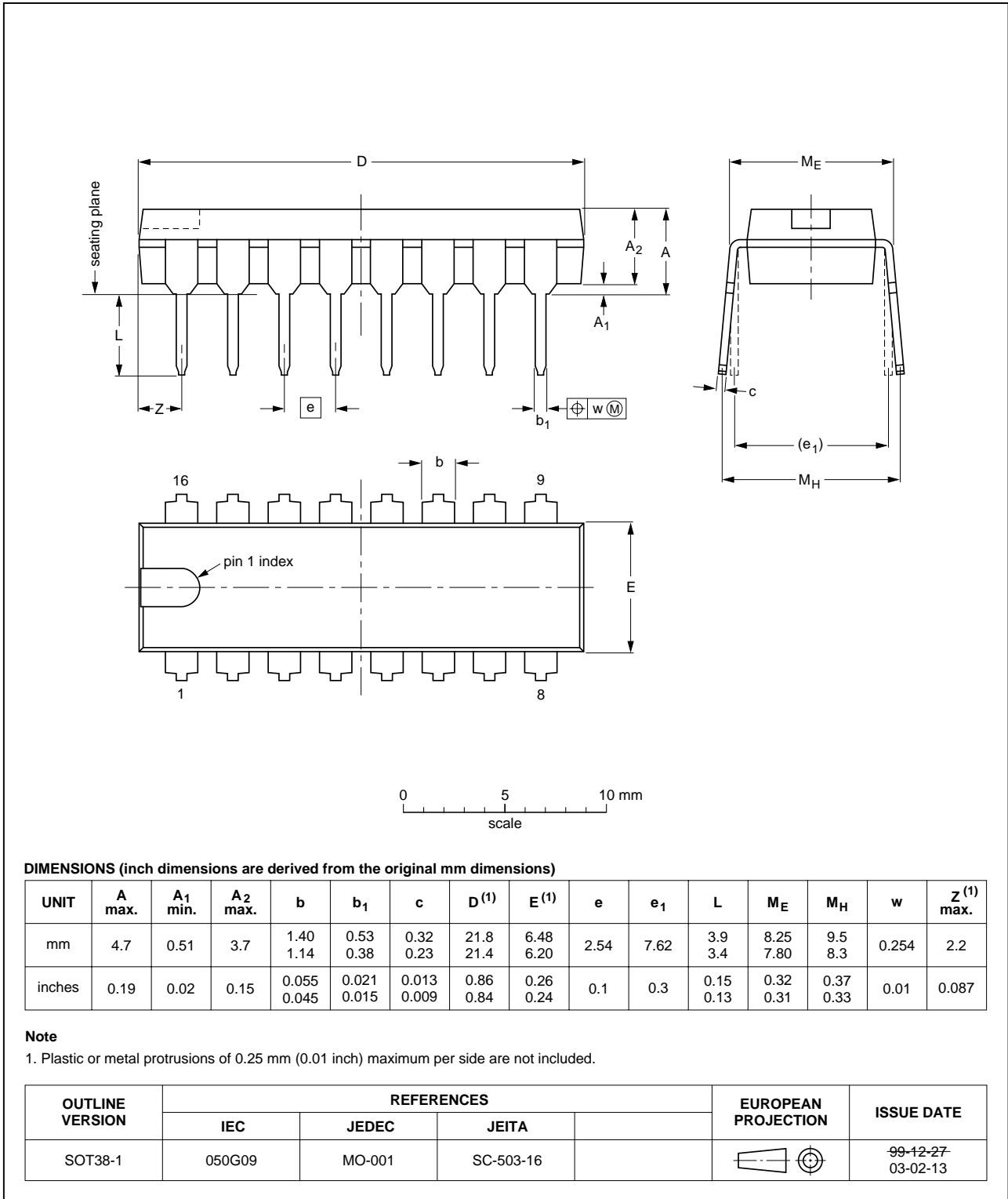

Fig 16. DIP16 package outline.

17. Soldering

17.1 Introduction to soldering through-hole mount packages

This text gives a brief insight to wave, dip and manual soldering. A more in-depth account of soldering ICs can be found in our *Data Handbook IC26; Integrated Circuit Packages* (document order number 9398 652 90011).

Wave soldering is the preferred method for mounting of through-hole mount IC packages on a printed-circuit board.

17.2 Soldering by dipping or by solder wave

Driven by legislation and environmental forces the worldwide use of lead-free solder pastes is increasing. Typical dwell time of the leads in the wave ranges from 3 to 4 seconds at 250 °C or 265 °C, depending on solder material applied, SnPb or Pb-free respectively.

The total contact time of successive solder waves must not exceed 5 seconds.

The device may be mounted up to the seating plane, but the temperature of the plastic body must not exceed the specified maximum storage temperature ($T_{stg(max)}$). If the printed-circuit board has been pre-heated, forced cooling may be necessary immediately after soldering to keep the temperature within the permissible limit.

17.3 Manual soldering

Apply the soldering iron (24 V or less) to the lead(s) of the package, either below the seating plane or not more than 2 mm above it. If the temperature of the soldering iron bit is less than 300 °C it may remain in contact for up to 10 seconds. If the bit temperature is between 300 and 400 °C, contact may be up to 5 seconds.

17.4 Package related soldering information

Table 10: Suitability of through-hole mount IC packages for dipping and wave soldering methods

Package	Soldering method	
	Dipping	Wave
DBS, DIP, HDIP, SDIP, SIL	suitable	suitable ^[1]
PMFP ^[2]	–	not suitable

[1] For SDIP packages, the longitudinal axis must be parallel to the transport direction of the printed-circuit board.

[2] For PMFP packages hot bar soldering or manual soldering is suitable.

18. Revision history

Table 11: Revision history

Rev	Date	CPCN	Description
03	20030902	-	Product data (9397 750 11707) Modifications: <ul style="list-style-type: none">• Updated Section 1 "General description"• Added one feature in Section 2 "Features"• Added one condition for the output power in Section 4 "Quick reference data"• Updated Table 4 "Power rating as function of headroom"• Added one condition for the output power in Section 12 "Dynamic characteristics"• Replaced Figure 8 "Output power as function of supply voltage."
02	20000314	-	Product data (9397 750 06862)
01	19990414	-	Preliminary data (9397 750 04879)

19. Data sheet status

Level	Data sheet status ^[1]	Product status ^{[2][3]}	Definition
I	Objective data	Development	This data sheet contains data from the objective specification for product development. Philips Semiconductors reserves the right to change the specification in any manner without notice.
II	Preliminary data	Qualification	This data sheet contains data from the preliminary specification. Supplementary data will be published at a later date. Philips Semiconductors reserves the right to change the specification without notice, in order to improve the design and supply the best possible product.
III	Product data	Production	This data sheet contains data from the product specification. Philips Semiconductors reserves the right to make changes at any time in order to improve the design, manufacturing and supply. Relevant changes will be communicated via a Customer Product/Process Change Notification (CPCN).

[1] Please consult the most recently issued data sheet before initiating or completing a design.

[2] The product status of the device(s) described in this data sheet may have changed since this data sheet was published. The latest information is available on the Internet at URL <http://www.semiconductors.philips.com>.

[3] For data sheets describing multiple type numbers, the highest-level product status determines the data sheet status.

20. Definitions

Short-form specification — The data in a short-form specification is extracted from a full data sheet with the same type number and title. For detailed information see the relevant data sheet or data handbook.

Limiting values definition — Limiting values given are in accordance with the Absolute Maximum Rating System (IEC 60134). Stress above one or more of the limiting values may cause permanent damage to the device. These are stress ratings only and operation of the device at these or at any other conditions above those given in the Characteristics sections of the specification is not implied. Exposure to limiting values for extended periods may affect device reliability.

Application information — Applications that are described herein for any of these products are for illustrative purposes only. Philips Semiconductors make no representation or warranty that such applications will be suitable for the specified use without further testing or modification.

21. Disclaimers

Life support — These products are not designed for use in life support appliances, devices, or systems where malfunction of these products can reasonably be expected to result in personal injury. Philips Semiconductors customers using or selling these products for use in such applications do so at their own risk and agree to fully indemnify Philips Semiconductors for any damages resulting from such application.

Right to make changes — Philips Semiconductors reserves the right to make changes in the products - including circuits, standard cells, and/or software - described or contained herein in order to improve design and/or performance. When the product is in full production (status 'Production'), relevant changes will be communicated via a Customer Product/Process Change Notification (CPCN). Philips Semiconductors assumes no responsibility or liability for the use of any of these products, conveys no licence or title under any patent, copyright, or mask work right to these products, and makes no representations or warranties that these products are free from patent, copyright, or mask work right infringement, unless otherwise specified.

Contact information

For additional information, please visit <http://www.semiconductors.philips.com>.

For sales office addresses, send e-mail to: sales.addresses@www.semiconductors.philips.com.

Fax: +31 40 27 24825

Contents

1	General description	1
2	Features	1
3	Applications	1
4	Quick reference data	2
5	Ordering information	2
6	Block diagram	3
7	Pinning information	3
7.1	Pinning	3
7.2	Pin description	4
8	Functional description	5
8.1	Input configuration	5
8.2	Power amplifier	6
8.2.1	Output power measurement	6
8.2.2	Headroom	6
8.3	Mode selection	6
8.3.1	Switch-on and switch-off	7
8.4	Supply voltage ripple rejection	7
8.5	Built-in protection circuits	7
8.5.1	Short-circuit protection	7
8.5.2	Thermal shutdown protection	7
9	Limiting values	8
10	Thermal characteristics	8
11	Static characteristics	8
12	Dynamic characteristics	9
13	Internal circuitry	14
14	Application information	15
14.1	Application diagram	15
14.2	Printed-circuit board	16
14.2.1	Layout and grounding	16
14.2.2	Power supply decoupling	17
14.3	Thermal behavior and $T_{amb(max)}$ calculation	17
15	Test information	17
15.1	Quality information	17
15.2	Test conditions	17
16	Package outline	18
17	Soldering	19
17.1	Introduction to soldering through-hole mount packages	19
17.2	Soldering by dipping or by solder wave	19
17.3	Manual soldering	19
17.4	Package related soldering information	19
18	Revision history	20
19	Data sheet status	21
20	Definitions	21
21	Disclaimers	21



PHILIPS

Let's make things better.