

THIS DRAWING IS UNPUBLISHED. RELEASED FOR PUBLICATION  
 © COPYRIGHT - By - ALL RIGHTS RESERVED.

LOC		DIST		REVISIONS			
P	LTR	DESCRIPTION		DATE	DWN	APVD	
AD	00	A3		REVISED PER ECO-11-004820	11MAR11	RK HMR	

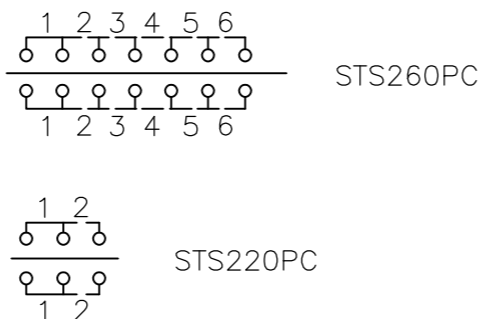
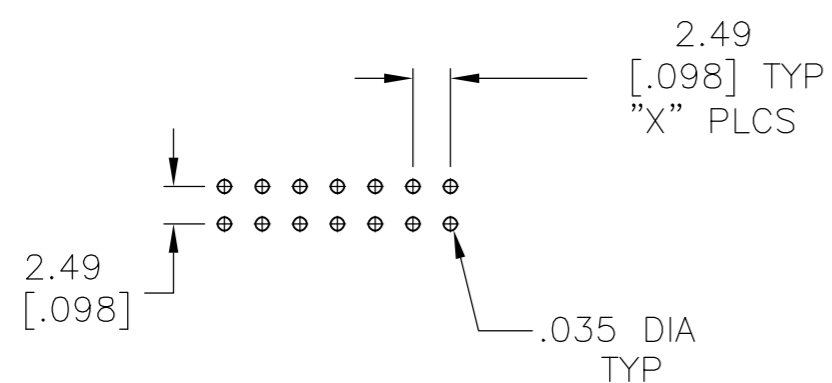
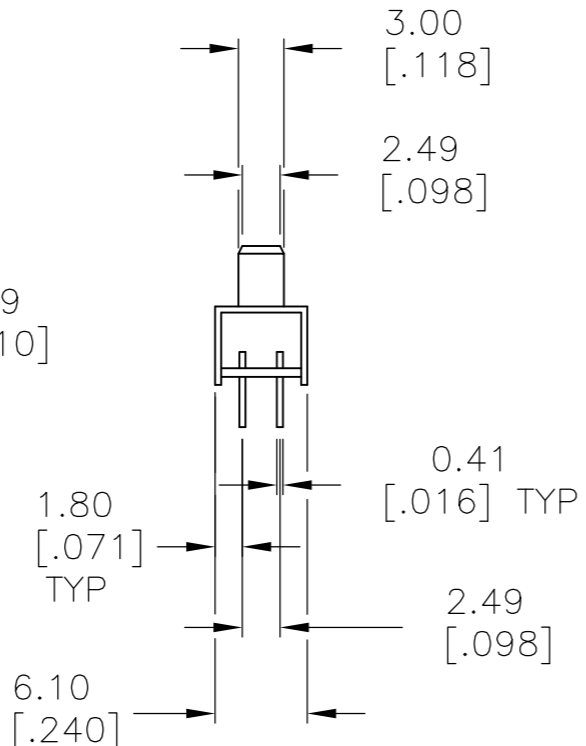
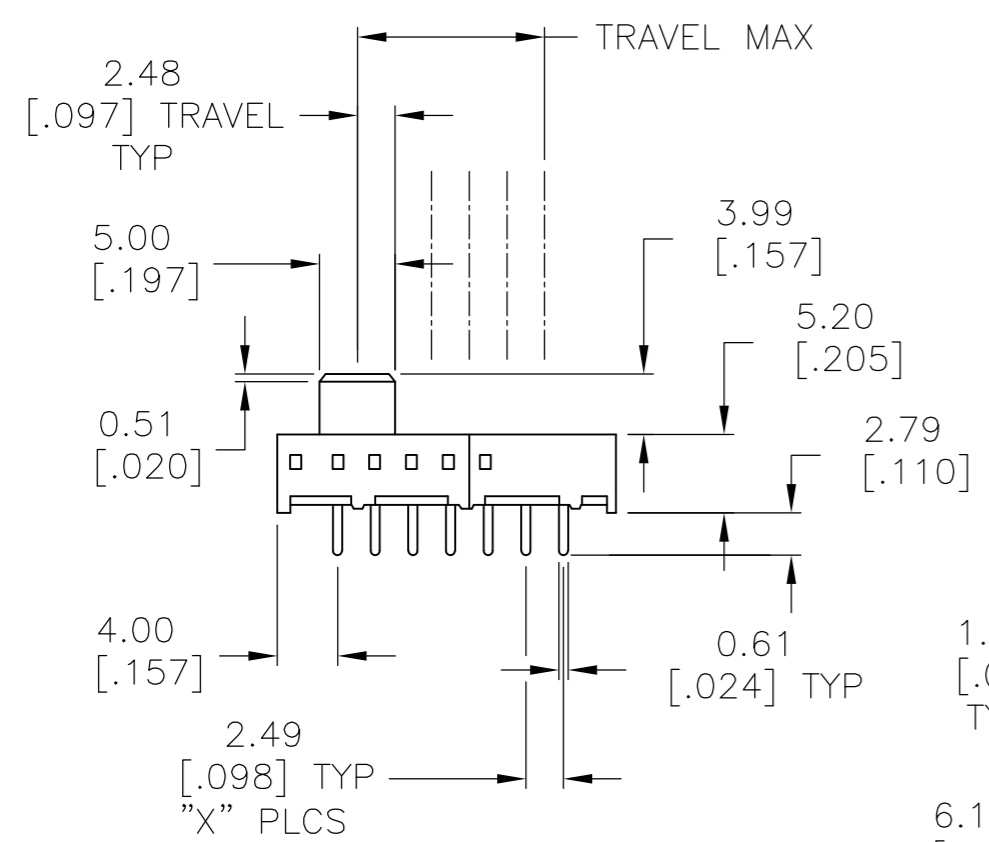
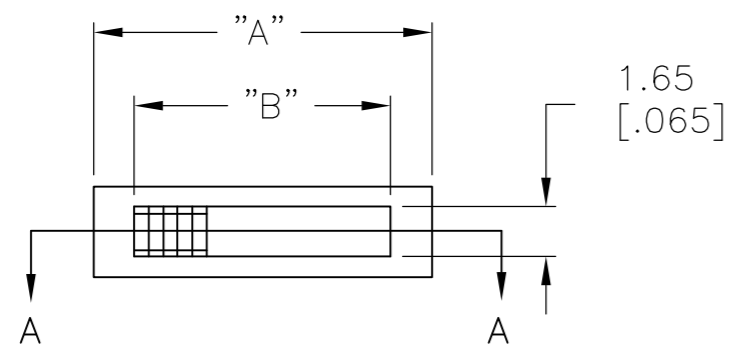

P.C. HOLE LAYOUT

EXAMPLES: MIN-MAX TRAVEL OF SWITCH

PART IDENTIFICATION	A DIM	B DIM	X PLC
STS 260PC (DP6T)	23.00 [0.906]	17.50 [0.689]	6 PLCS
STS 250PC (DP5T)	20.50 [0.807]	15.00 [0.591]	5 PLCS
STS 240PC (DP4T)	18.00 [0.709]	12.50 [0.492]	4 PLCS
STS 230PC (DP3T)	15.50 [0.610]	10.00 [0.394]	3 PLCS
STS 220PC (DP2T)	13.00 [0.512]	7.50 [0.295]	2.50 [0.098]

SPECIFICATIONS:  
 MAKE-BEFORE-BREAK

MATERIALS:  
 FRAME: STEEL, ZINC PLATE  
 ACTUATOR: POM UL94HB, BLACK  
 FIXED CONTACT/TERMINAL: COPPER ALLOY, SILVER OVER NICKEL PLATE  
 MOVING CONTACT: COPPER ALLOY, SILVER CLAD  
 COIL SPRING: TEMPERED STEEL WIRE  
 BALL- TEMPERED CARBON STEEL  
 TERMINAL BOARD: PHENOLIC, UL94HB  
 TERMINAL SEAL: EPOXY

ELECTRICAL:  
 CONTACT RATING: 250 MILLIAMPS@125V AC  
 CONTACT RESISTANCE: 30 MILLIOHMS MAX (INITIAL), 60 MILLIOHMS AFTER TEST  
 INSULATION RESISTANCE: 500 MEGOHMS MIN AT 500V DC  
 DIELECTRIC STRENGTH: 500 VAC RMS AT SEA LEVEL  
 LIFE EXPECTANCY: 10,000 CYCLES MIN. NO LOAD

MECHANICAL:  
 ACTUATION FORCE: 250 +150/-100 GRAMS  
 TRAVEL: .098 (2.49MM)

ENVIRONMENTAL:  
 OPERATING TEMPERATURE: -10°C TO +60°C  
 STORAGE TEMPERATURE: -10°C TO +60°C  
 RESISTANCE TO SOLDER HEAT: 260°C FOR 10 SEC PER 109-202, COND. B  
 SOLDERABILITY: PER EIA-364-56A, PROCEDURE 3, COND. B

- NOTES:
- ALL MATERIALS AND FINISHES SHALL COMPLY WITH EU DIRECTIVE 2002/95/EC OF 27JAN2003 (ROHS)
  - ALL PERFORMANCE SPECIFICATIONS WERE TESTED IN ACCORDANCE WITH JIS-C-5441 UNLESS OTHERWISE STATED.

X PLC	DIM B	DIM A	FUNCTION	T&B P/N	PART NO.
6	17.50 [0.689]	23.00 [0.906]	DP6T	STS260PC04	1825163-5
5	15.00 [0.591]	20.50 [0.807]	DP5T	STS250PC04	1825163-4
4	12.50 [0.492]	18.00 [0.709]	DP4T	STS240PC04	1825163-3
3	10.00 [0.394]	15.50 [0.610]	DP3T	STS230PC04	1825163-2
2	7.50 [0.295]	13.00 [0.512]	DPDT	STS220PC04	1825163-1

THIS DRAWING IS A CONTROLLED DOCUMENT.

DWN: B.S.VISWESWARA 31MAR05	 TE Connectivity SWITCH-SLIDE (DP*T) P/N STS2*0PC	SIZE	CAGE CODE	DRAWING NO	RESTRICTED TO
CHK: M S SARVER		A2	00779	C=1825163	-
APVD: M S SARVER		SCALE	SHEET	REV	
PRODUCT SPEC		2:1	1 of 2	A3	
APPLICATION SPEC	CUSTOMER DRAWING				

THIS DRAWING IS UNPUBLISHED. RELEASED FOR PUBLICATION  
 © COPYRIGHT - By - ALL RIGHTS RESERVED.

LOC	DIST	REVISIONS			
P	LTR	DESCRIPTION	DATE	DWN	APVD
AD	00	SEE SHEET 1	-	-	-

PART NUMBER POSITION BOTTOM VIEW

FUNCTION DIAGRAM

-1

2

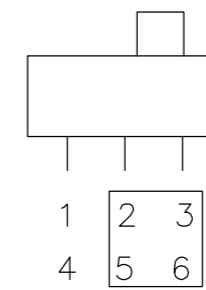
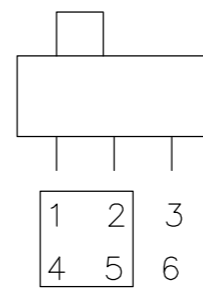
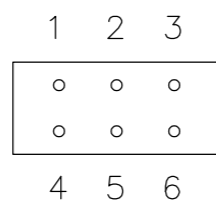

-2

3

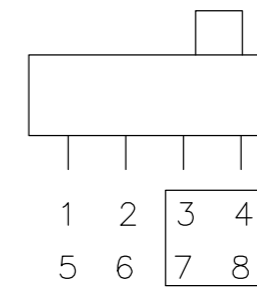
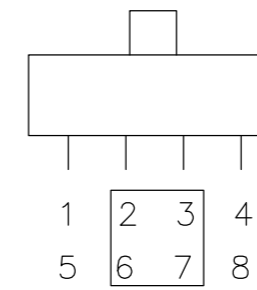
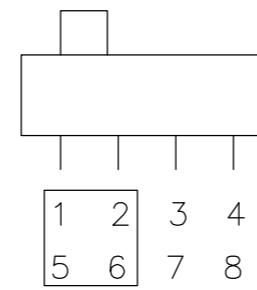
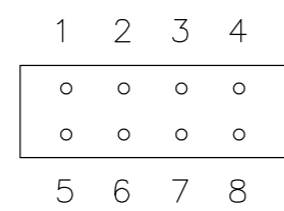

-3

4

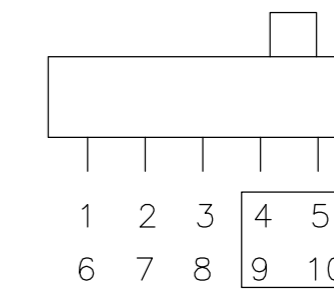
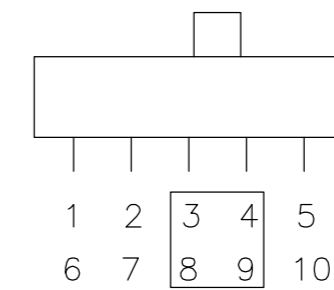
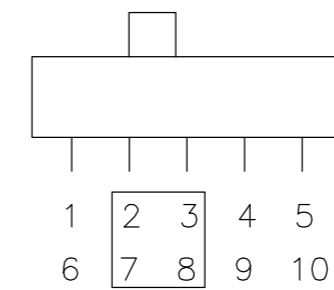
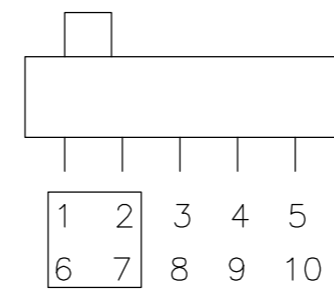
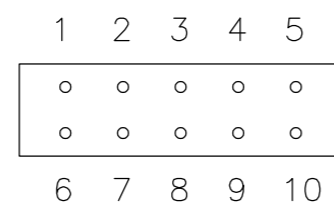

-4

5

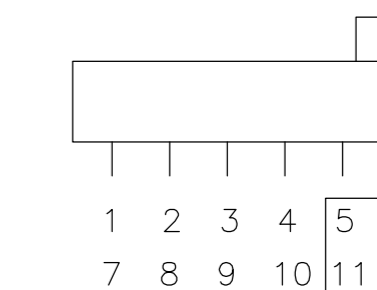
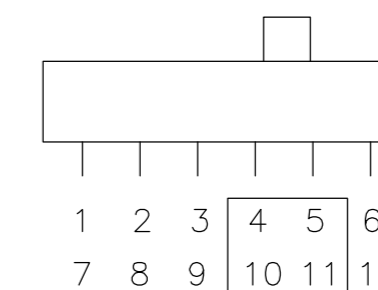
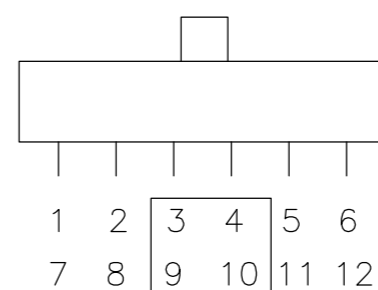
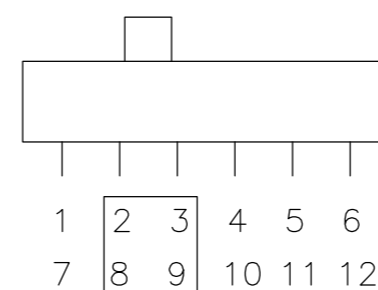
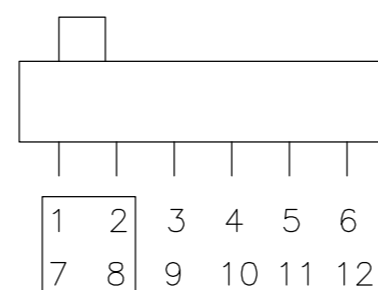
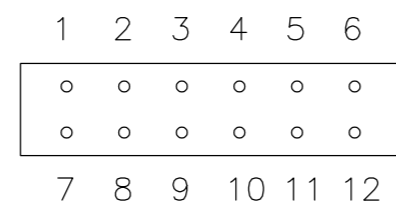

-5

6

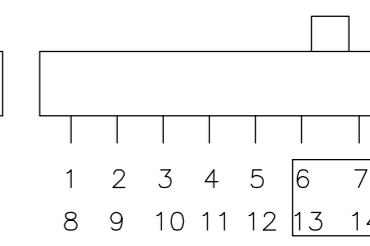
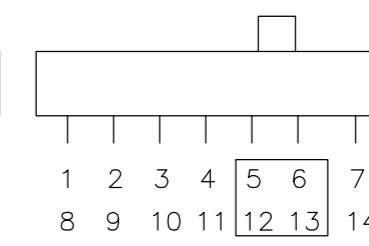
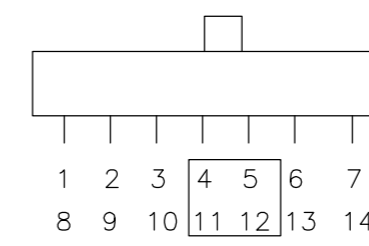
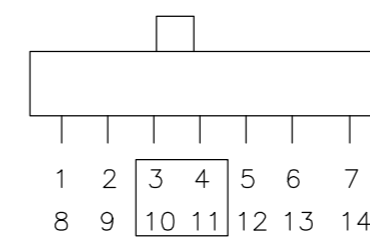
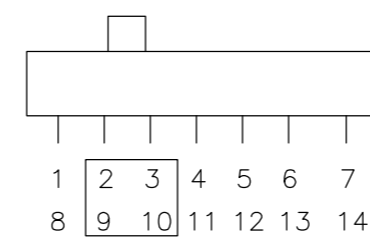
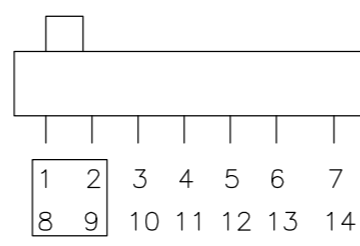
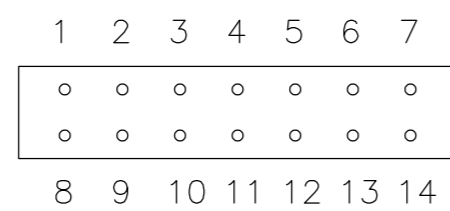

THIS DRAWING IS A CONTROLLED DOCUMENT.		DWN B.S.VISWESWARA 31MAR05		
DIMENSIONS: mm [INCHES]		CHK M S SARVER		
TOLERANCES UNLESS OTHERWISE SPECIFIED: 0 PLC ± - 1 PLC ± - 2 PLC ± .008(0.20) 3 PLC ± - 4 PLC ± - ANGLES ± 1°		APVD M S SARVER	NAME SWITCH-SLIDE (DP*T) P/N STS2*0PC	
MATERIAL -		FINISH -	WEIGHT -	RESTRICTED TO -
CUSTOMER DRAWING		SCALE 2:1	SHEET 2 OF 2	REV A3