

THIS DOCUMENT IS THE PROPERTY OF
KEYSTONE ELECTRONICS CORP. AND
SHALL NOT BE REPRODUCED, DISTRIBUTED
OR USED AS A BASIS FOR MANUFACTURE
WITHOUT PRIOR WRITTEN PERMISSION
FROM KEYSTONE ELECTRONICS CORP.

PANEL CUT

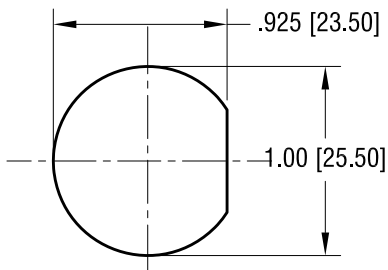

ACTUAL SIZE

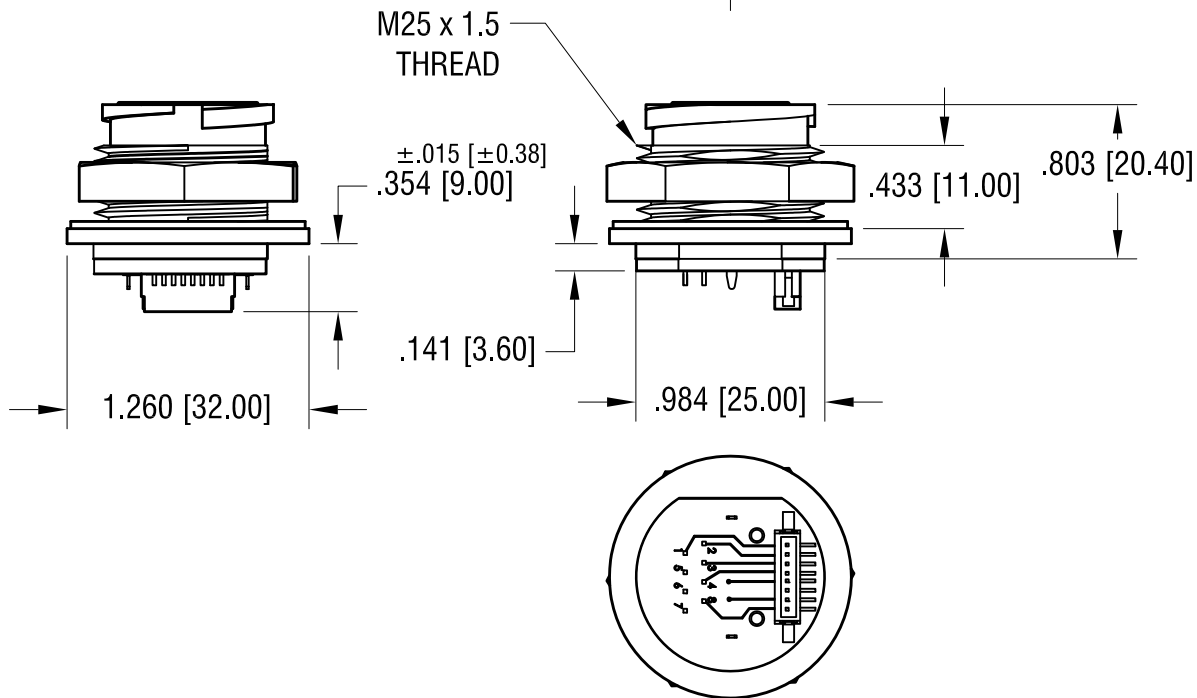
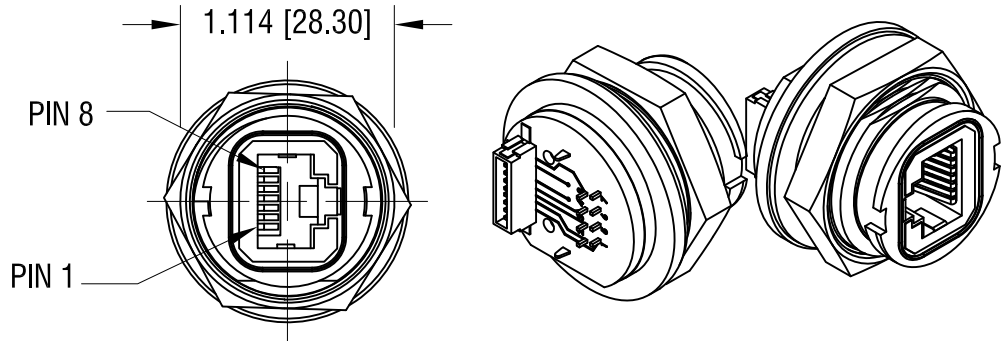

NOTE:

1. HOUSING: MAT'L- HIGH. TEMP.. THERMOPLASTIC
UL 94V-0
2. CONTACT: MAT'L- PHOSPHOR BRONZE
FINISH ON SOLDER AREA: TIN PLATE, OVER NICKEL
FINISH ON CONTACT AREA: GOLD PLATE, OVER NICKEL

KEYSTONE ELECTRONICS CORP.

www.keyelco.com • ASTORIA, N.Y. 11105-2017 • Tel (718) 956-8900

PART NAME

OFF BOARD WATER PROOF KEYSTONE JACK

MATERIAL

AS NOTED

FINISH

AS NOTED

DRN BY

NT

DATE

4.04.16

APP'D

LN

SCALE

1X

TOLERANCES

INCH [MM]

DECIMAL ± .005 [± 0.13]

ANGULAR ± 1°

UNLESS OTHERWISE SPECIFIED

CODE

C

DWG NO.

961

DATE

DESCRIPTION

REV.