

THIS DRAWING IS UNPUBLISHED. RELEASED FOR PUBLICATION, 19 .
 © COPYRIGHT 19 BY AMP INCORPORATED. ALL INTERNATIONAL RIGHTS RESERVED.

LOC	DIST	P	F	REVISIONS				
				ZONE	LTR	DESCRIPTION	DATE	APPD
AF	50				J	REVISED AF-8068	8/4/92	JR/JG

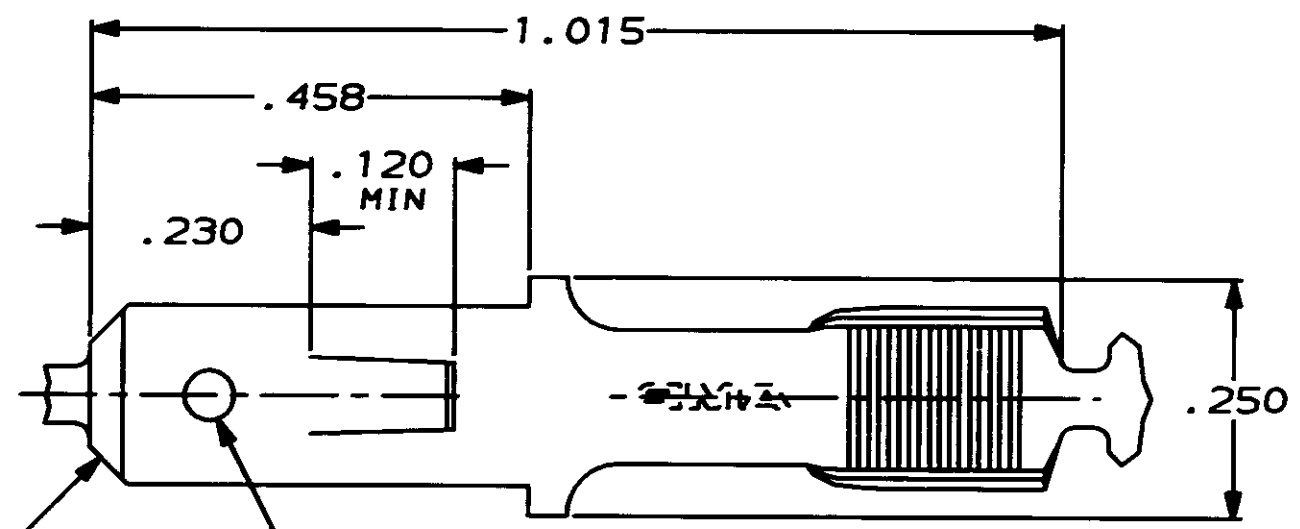

.065
.059 DIA HOLE

FITS .187 SERIES FASTON RECEPTACLE

- 1 CONTINUOUS STRIP ON REELS
- 2 REVERSE REELING FROM 62445-2.

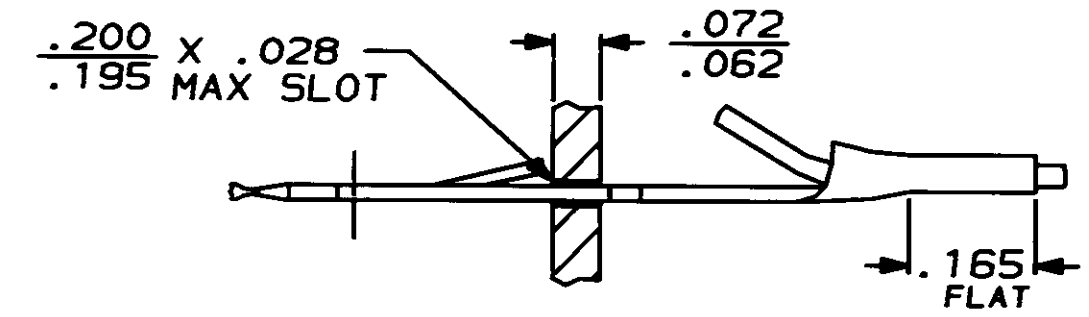

INSTALLED VIEW
PIGTAIL CRIMP

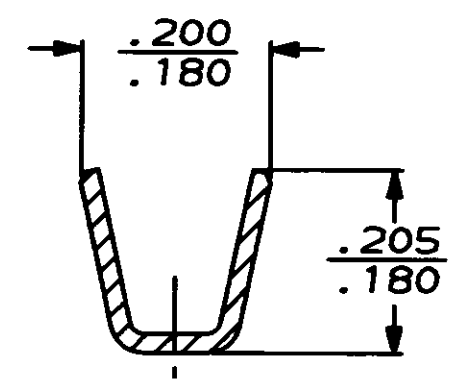
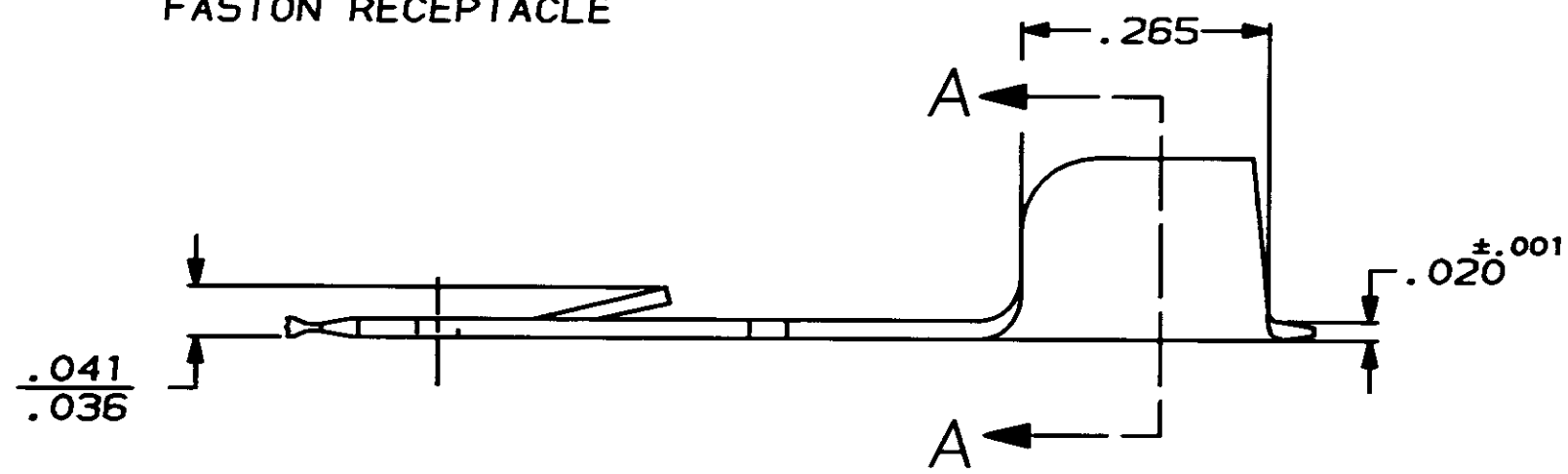

SECTION A-A

#15-12 MAGNET WIRE 3000 - 7000 CMA	TIN / VARNISH RESIST	△ 62445-3
	TIN .000080 MIN	62445-2
		62445-1
WIRE SIZE	FINISH	PART NO

DO NOT SCALE PRINT. UNLESS SPECIFIED DIMENSIONS ARE IN INCHES TOLERANCES ON: 2 PLC DEC ± - 3 PLC DEC ± .015 ANGLES ± -	DR 11/7/91 JR BATH	AMP AMP Incorporated Harrisburg, PA 17105-3608		
	CHK 11/7/91 NS FEMER			
	APPD 11/7/91 J GILLESPIE	NAME		
	APPD 11/7/91 D REIMER	TAB, AMPLIVAR, FASTIN-FASTON, .187 SERIES		
MATERIAL H02 BRASS	PRODUCT SPEC -	SIZE B	CAGE CODE 00779	DRAWING NO 62445
FINISH SEE TABLE	APPLICATION SPEC -	SCALE 5:1	SHEET 1 OF 1	
WEIGHT -				