

LOC	DIST	REVISIONS			
P	LTR	DESCRIPTION	DATE	DWN	APVD
AF	50	1	PROPOSED	-	-

- 1 CONTINUOUS STRIP ON REELS WITH TERMINALS LOCATED ON 6.86±0.08 [.270±.003] CENTERS
- 2 SLOT ACCEPTS 0.57-0.81mm [#23-#20] AWG COPPER MAGNET WIRE. TWO WIRES OF THE SAME SIZE MAX PER SLOT FOR #23 GAGE. ONE WIRE MAX PER SLOT FOR #22-#20 AWG
- 3 IDENTIFICATION NUMBER 15 FOR THE MAGNET WIRE SLOT SIZE.
- 4 0.25 [.010] MAX CARRIER CUT-OFF
- 5 PRELIMINARY - NOT FOR PRODUCTION

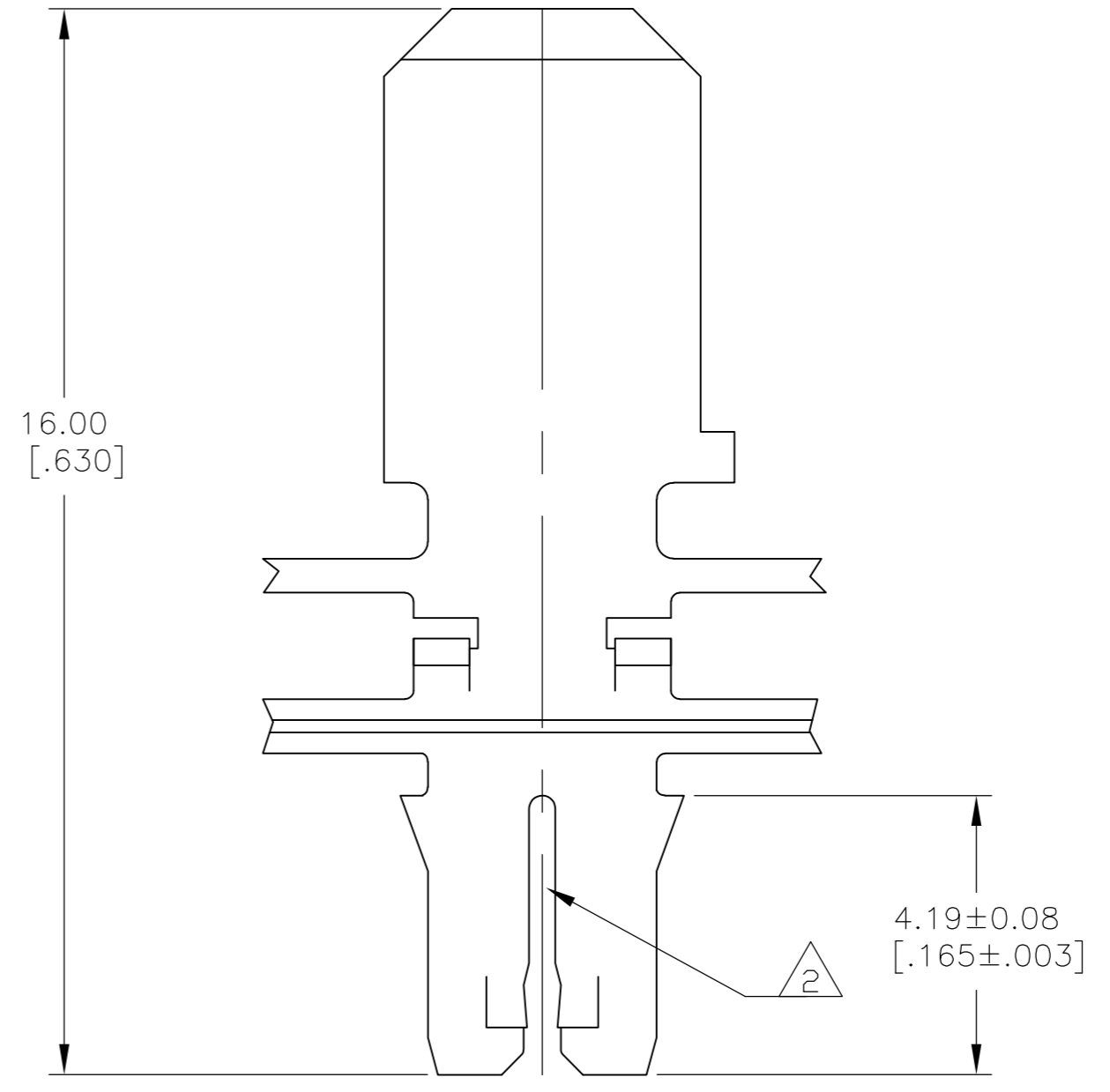
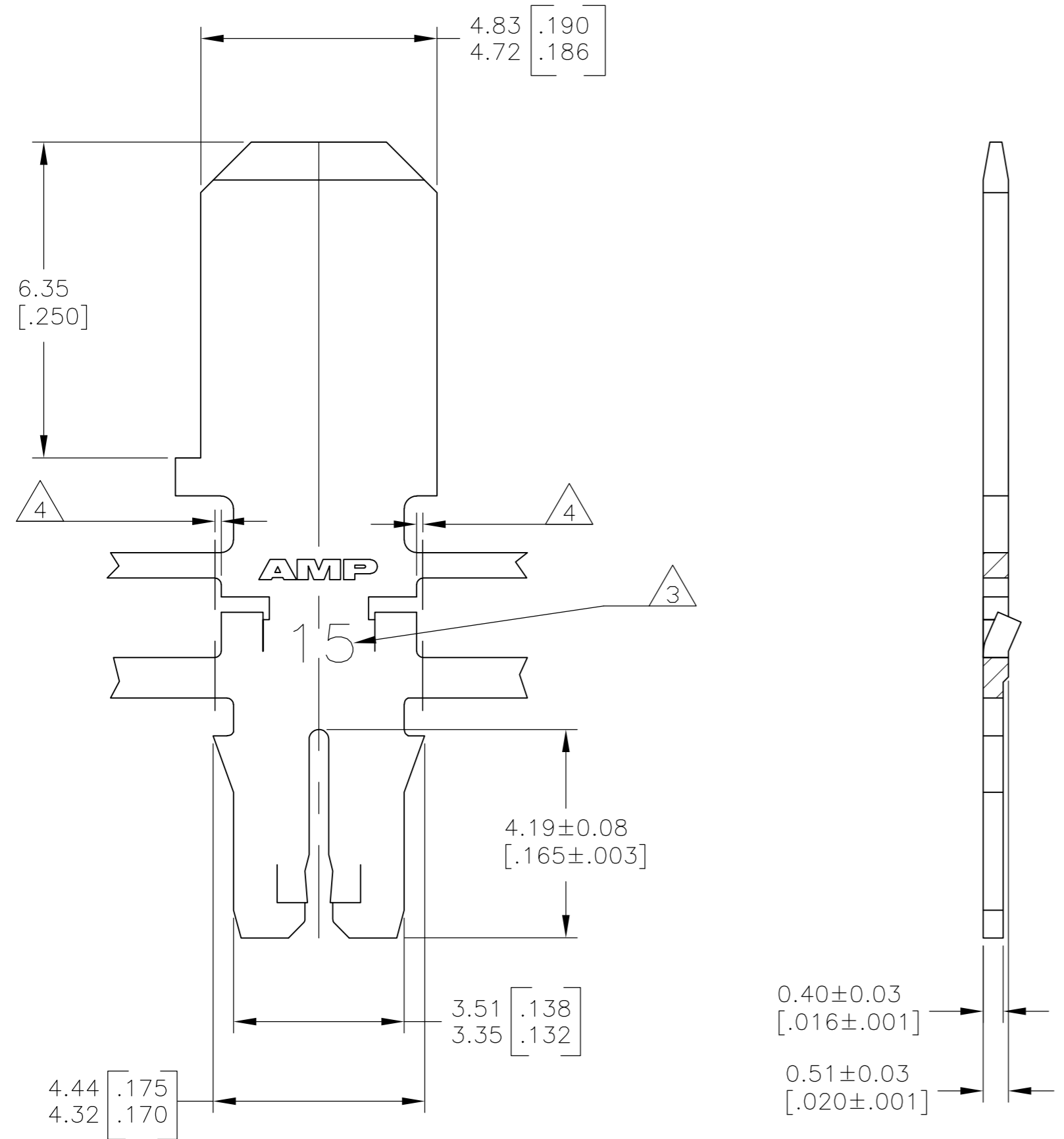

0.002032 [.000080] MIN TIN PLATE	082 PRE-MILLED BRASS	5 1742860-1
FINISH	MATERIAL	PART NO.

THIS DRAWING IS A CONTROLLED DOCUMENT.		DWN JR RUTH 27OCT10	Tyco Electronics Corporation Harrisburg, PA 17105-3608	
DIMENSIONS: MM [INCHES]	TOLERANCES UNLESS OTHERWISE SPECIFIED:	CHK KURT RANDOLPH 27OCT10	<b>PRELIMINARY</b> TAB, 4.75 [.187] PLAIN, MAG-MATE™ Slim Line	
0 PLC ± - 1 PLC ± - 2 PLC ± 0.13 [.005] 3 PLC ± - 4 PLC ± - ANGLES ± -	FINISH SEE TABLE	APVD KURT RANDOLPH 27OCT10		
MATERIAL SEE TABLE	FINISH SEE TABLE	PRODUCT SPEC 108-1484	APPLICATION SPEC 114-2140	RESTRICTED TO -
CUSTOMER DRAWING		WEIGHT -	SIZE A2	CAGE CODE 00779
		DRAWING NO. 1742860		SCALE 10:1
		SHEET 1 of 1		REV 1