

**IMPEL
Backplane Module
Installation
Press-In Tool**

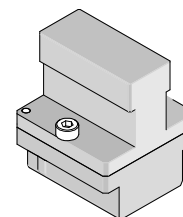

**Application Tooling
Specification Sheet**



Order No. 62201-8955

FEATURES

- Polarized tool prevents product damage
- Tool provides uniform distribution of press force across entire pin array
- May be used as a stand-alone tool or mounted in an optional holder with other Molex press-in tools

SCOPE

Products: IMPEL (1.9mm pitch) Backplane Assembly, (4-Pair by 16 Column Assemblies). See Product List below for specific part numbers.

Product List

The following is a partial list of the product order numbers and their specifications this tool is designed to run. Updates to this list are available on www.molex.com.

Series No.	Guide Style	Columns	Assembly Order Number					
171315	Unguided	16	171315-1604	171315-1605	171315-1607	171315-1608	171315-1614	171315-1615
			171315-1617	171315-1618	171315-1624	171315-1625	171315-1627	171315-1628
			171315-1634	171315-1635	171315-1637	171315-1638		
	Left Guided	16	171315-3604	171315-3605	171315-3607	171315-3608	171315-3614	171315-3615
			171315-3617	171315-3618	171315-3624	171315-3625	171315-3627	171315-3628
			171315-3634	171315-3635	171315-3637	171315-1338	171315-3644	171315-3645
			171315-3647	171315-3648	171315-3654	171315-3655	171315-3657	171315-3658
			171315-3664	171315-3665	171315-3667	171315-3668	171315-3674	171315-3675
			171315-3677	171315-3678	171315-3684	171315-3685	171315-3687	171315-3688
			171315-7604	171315-7605	171315-7607	171315-7608	171315-7614	171315-7615
			171315-7617	171315-7618	171315-7624	171315-7625	171315-7627	171315-7628
			171315-7634	171315-7635	171315-7637	171315-7638	171315-7644	171315-7645
			171315-7647	171315-7648	171315-7654	171315-7655	171315-7657	171315-7658
			171315-7664	171315-7665	171315-7667	171315-7668	171315-7674	171315-7675
			171315-7677	171315-7678	171315-7684	171315-7685	171315-7687	171315-7688
	Right Guided	16	171315-5604	171315-5605	171315-5607	171315-5608	171315-5614	171315-5615
			171315-5617	171315-5618	171315-5624	171315-5625	171315-5627	171315-5628
			171315-5634	171315-5635	171315-5637	171315-5638	171315-5644	171315-5645
			171315-5647	171315-5648	171315-5654	171315-5655	171315-5657	171315-5658
			171315-5664	171315-5665	171315-5667	171315-5668	171315-5674	171315-5675
			171315-5677	171315-5678	171315-5684	171315-5685	171315-5687	171315-5688
			171315-9604	171315-9605	171315-9607	171315-9608	171315-9614	171315-9615
			171315-9617	171315-9618	171315-9624	171315-9625	171315-9627	171315-9628
			171315-9634	171315-9635	171315-9637	171315-9638	171315-9644	171315-9645
			171315-9647	171315-9648	171315-9654	171315-9655	171315-9657	171315-9658
			171315-9664	171315-9665	171315-9667	171315-9668	171315-9674	171315-9675
			171315-9677	171315-9678	171315-9684	171315-9685	171315-9687	171315-9688

Tool Setup

Depending on the number of connectors to be installed and/or the press used, this tool can be used alone or with a group of press-in tools, mounted in a 62201-95XX rail (ordered separately). See Figure 1.

Tool Installation

The 62201-95XX rail is available in a variety of lengths to accommodate multiple press-in tools.

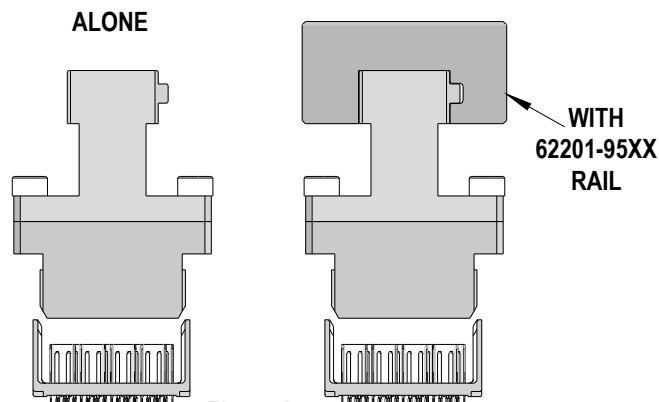

Figure 1

Rail Part Number	Rail Overall Length
62201-9501	24mm (0.94 in)
62201-9502	72mm (2.83 in)
62201-9503	156mm (6.14 in)
62201-9504	216mm (8.50 in)
62201-9509	254mm (10.0 in)
62201-9511	305mm (12.0 in)

Reference: This Press-In Tool is 31.10mm (1.22 in.) long.

Printed Circuit Board (PCB) Support

The IMPEL connectors require up to 3.6kg (8 lb) of force per pin to press into the PCB. To prevent excessive PCB flexure and/or damage to the PCB, a support plate is strongly recommended directly beneath the connector hole pattern.

Due to the custom nature of every application, Molex does not offer any PCB support plate. The customer must furnish their own support plate.

When creating the PCB support plate, remember to allow clearance for the connector pins as they pass through the PCB thickness.

Press Equipment Recommendations

Many types of presses can be used to install IMPEL connectors, but to assure consistent connector installation Molex recommends the following press criteria:

1. The capability to detect force variations as low as 4.5kg (10 lb) during the press-in cycle; excessive force measurements should stop the press-in cycle.
2. The rate of pressing can be regulated as low as 0.13mm (0.005 in) per second.
3. Press stroke control to within 0.25mm (0.010 in).
4. Total press stroke must be at least 19mm (0.75 in).
5. For statistical purposes, automatic collection of force and distance data.

Tool Operation

1. Insert by hand the backplane signal module assembly (s) carefully into the PCB hole pattern. Make sure the connector(s) are oriented properly by confirming the location of the #1 circuit notch with respect to the PCB layout.
2. Insert the Press-In Tool making sure that the notch in this tool is inserted into the slot on top of the connector housing of the backplane signal module assembly. See Figure 2.
3. Using the application tool and an appropriate press, seat the header assembly until there is less than 0.10mm (.004 in) clearance between the bottom of the plastic housing and the surface of the PCB. See Figure 3.

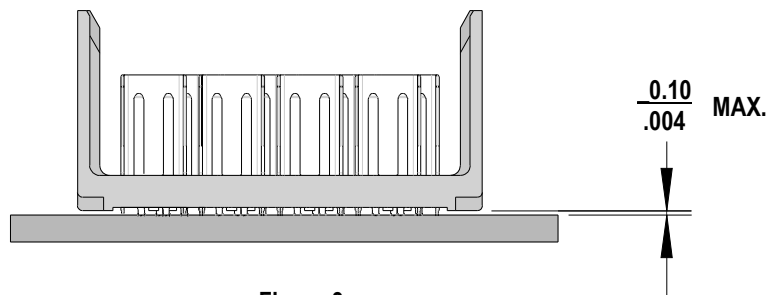
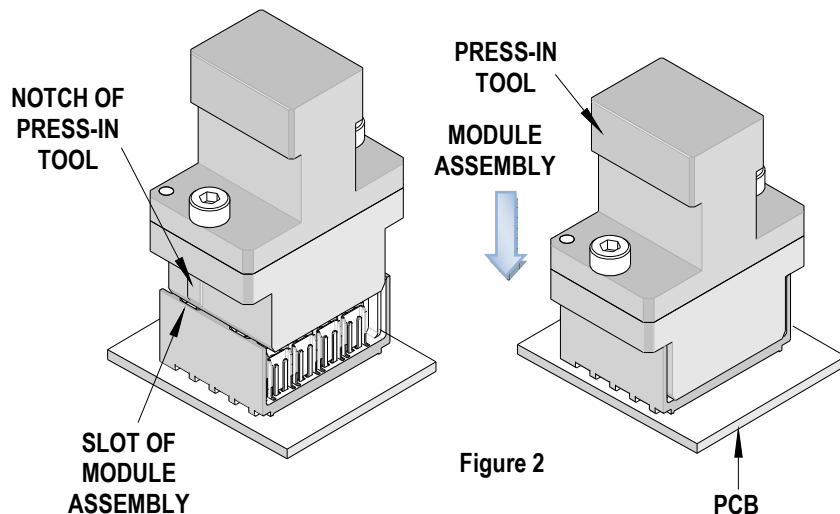

Figure 3

There should be no broken stand-offs along the perimeter of the part (an indication of over-pressing).

CAUTION: To prevent injury, never operate any press without the guards in place. Refer to the press manufacturer's instruction manual.

CAUTION: Molex application tooling specifications are valid only when used with Molex connectors and tooling.

Contact Information

For more information on Molex application tooling please contact Molex at 1-800-786-6539.

Visit our Web site at <http://www.molex.com>