

DIMENSIONS IN INCHES (MILLIMETERS)
DO NOT SCALE DRAWING...

Drawing No.
GRSV-4011-0011 THRU 0013

1 OF 2

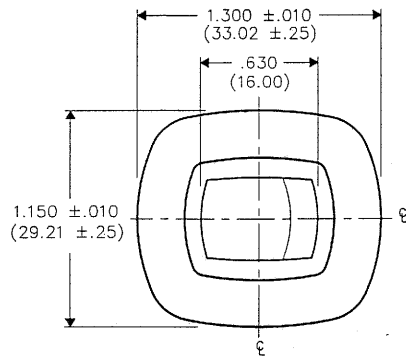

BACK PANEL PIERCING

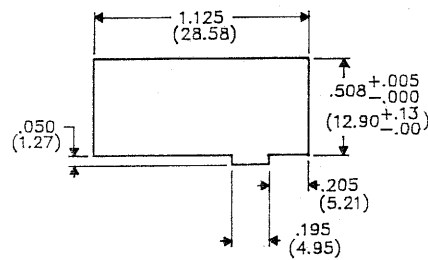

GLASS PANEL PIERCING

.172 - .202 PANEL THICKNESS
(4.37 - 5.13)

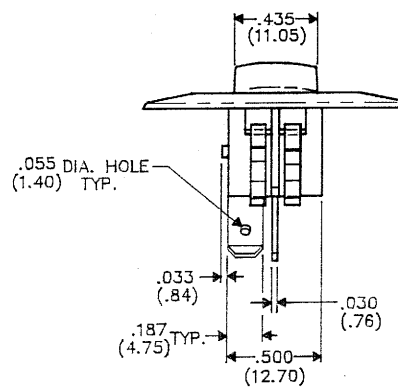
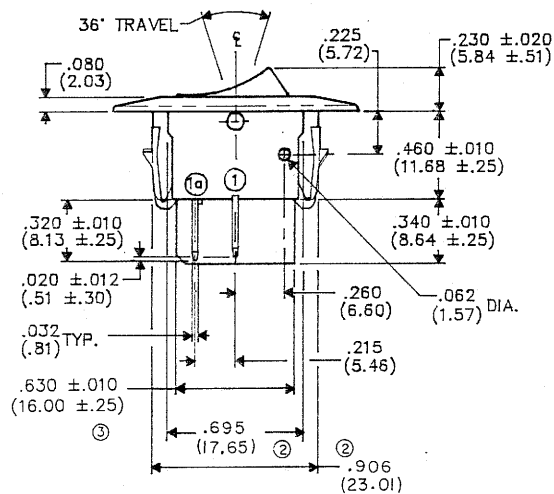
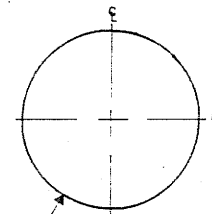

PART NO.	MAT'L.	COLOR
-0011	VALOX	BLACK
-0012	VALOX	WT-1334
-0013	VALOX	ALMOND 50046

REVISIONS
1 RELEASED DGW 12-28-93
2 ADDED PAGE 2; DGW 1-24-94
3 .695 WAS .722 & .906 WAS .880 IN FRONT VIEW. DGW 1-15-95 G.G.
4 ADDED ±.010 TO .630 IN FRONT VIEW. IDCW 1-29-98 G.G.
5 REMOVED BULB PAD PRINT & DIM'S .180 REF. & .162 REF. FROM TOP VIEW. DGW 2-10-2005 G.G. FEB 11 2005

CW INDUSTRIES
Southampton, Pa. 18966

TOLERANCES UNLESS OTHERWISE SPECIFIED
2 Place decimal ±.010 METRIC
3 Place decimal ±.005 1 Place dec. ± .25 MM
Angles ± 1° 2 Place dec. ± 13 MM

Made for: GE
Drawn by: DGW 12-28-93
Checked by: G.G. 1-6-94
Approval: [Signature]

Title: SWIDGET CUSTOM S.P.- S.T.

Division: SWITCH

Drawing No: GRSV-4011-0011 THRU 0013

1 OF 2

DIMENSIONS IN INCHES (MILLIMETERS)
DO NOT SCALE DRAWING...

Drawing No.
GRSV-4011-0011 THRU 0013

2 OF 2

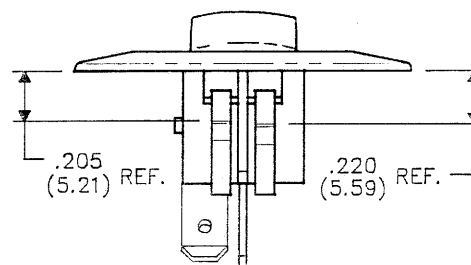
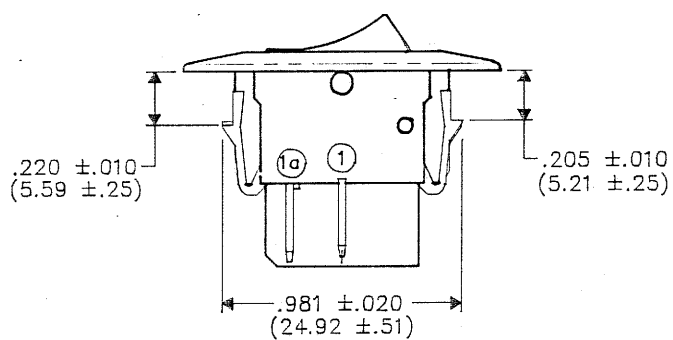

B-FORM-0

REVISIONS

0
RELEASED
DGW 1-24-94

PDF File Made

CW INDUSTRIES
Southampton, Pa. 18966

TOLERANCES UNLESS OTHERWISE SPECIFIED
 2 Place decimal ±.010 METRIC
 3 Place decimal ±.005 1 Place dec. ±.25 MM
 Angles ±1° 2 Place dec. ±.13 MM

Made for GE
 Drawn by DGW 1-24-94
 Checked by *[Signature]* 1/27/94
 Approval *[Signature]* 1-24-94

Title
CLAW DETAILS

Division
SWITCH

Drawing No.
GRSV-4011-0011 THRU 0013

2 OF 2