

1. 97-621.1 PROG. DIE-CUT TO LENGTH
 (16.210 IN. LONG) (12 STROKES)
 2. DEGREASE

3. H.T.
 4. INSP.
 5. STOCK

6. FINISH AS REQ'D
 7. FINAL INSP.
 8. SHIPPING

16 IB₂ENT₂LLIHHIPPIXW

DWG. NO.
 0097-C-0622

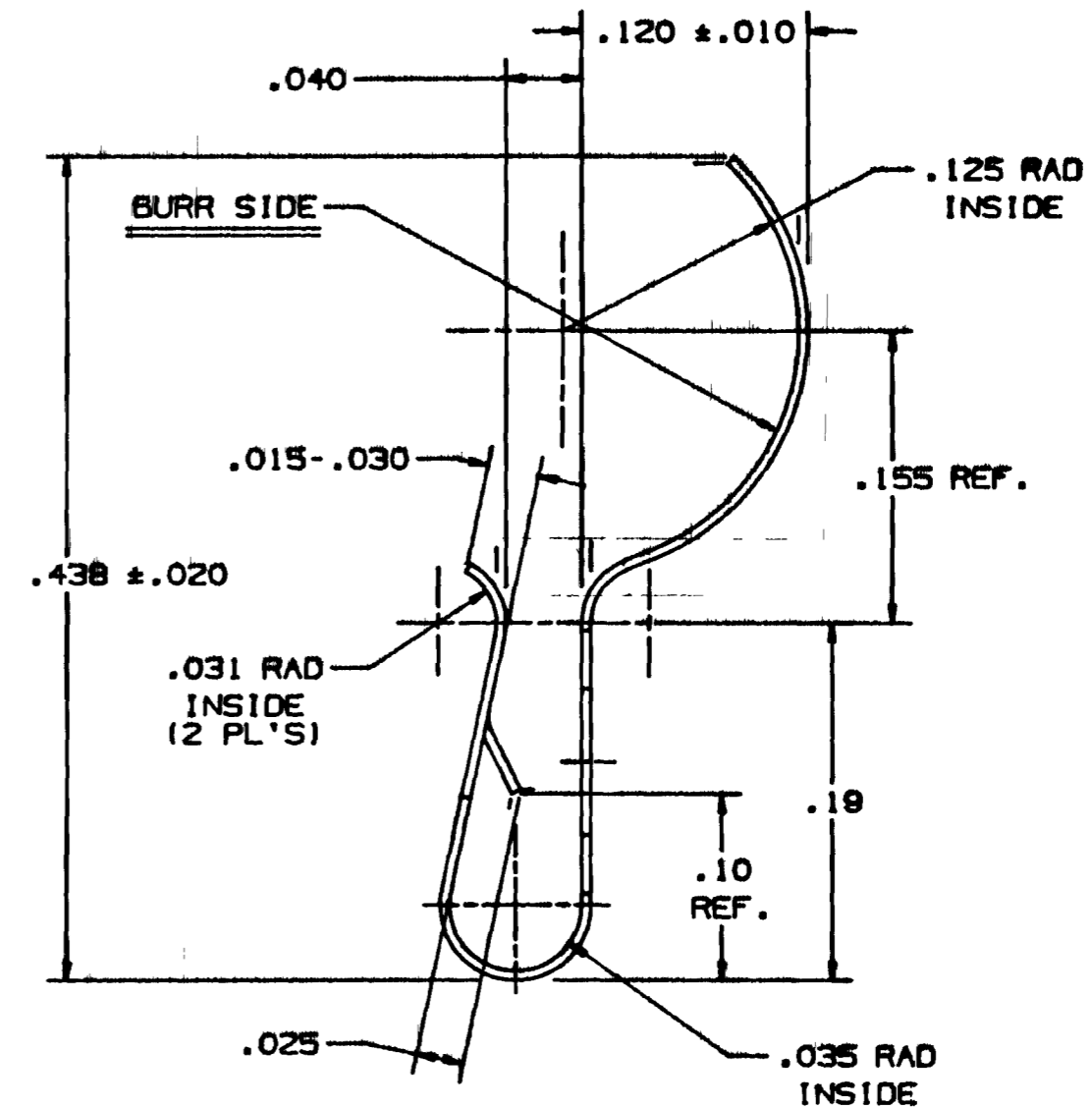
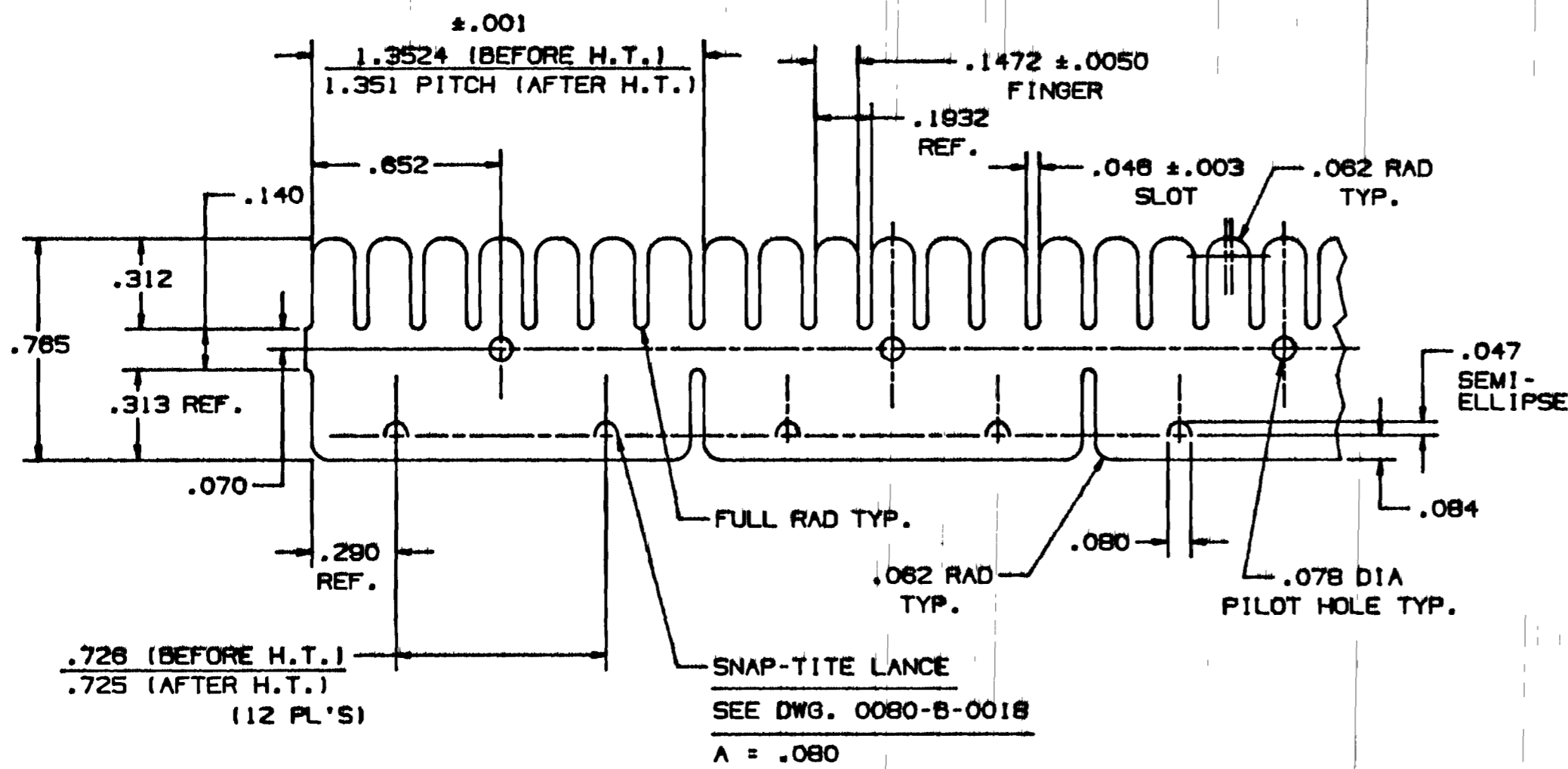
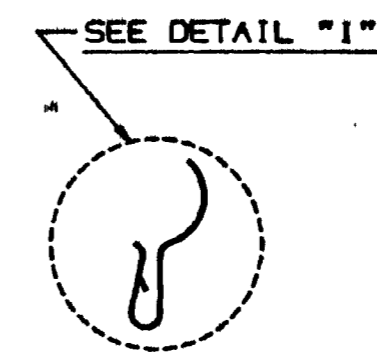
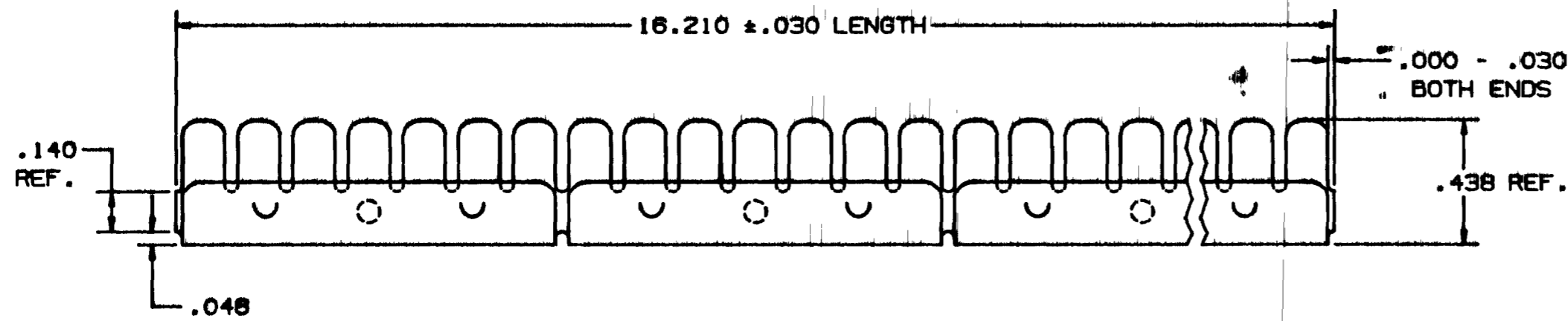

DETAIL "1"
 SCALE = 10:1

PARTIAL FLAT BLANK

SCALE = 2 : 1

DWG. NO.
 0097-C-0622

MATERIAL: .0003 .005 BE. CU. - ALLOY 25 - 1/2 HARD - END. GRADE	.003 • .858 22.7	TOLERANCES NOT SHOWN DECIMAL 2 PL'S ± .020 DECIMAL 3 PL'S ± .010	DRAWN BY M.V. 12-23-87
HEAT TREAT: TO DPH 343 MIN. USING A 500 GRAM LOAD		FRACTIONAL ± ANGULAR ± BEND RADII ±.010	CHECKED BY WHS. 12-23-87
THICKNESS AFTER CLEANING .0045 MIN.		CORNER RADII ±.005 MAXIMUM BURR	APPROVED BY WHS. 12-23-87
FINISH: AS REQUIRED	NO. FT./IN 154.0	PRODUCTION REVISED SETTINGS SCALE 2 : 1	REF. DWG. NO. 0711-C-0061 - DWG. NO. 0097-C-0622 01