

1 FIGURE OF INSERTION

HORIZONTALLY ○

DF57H-2S-1.2C

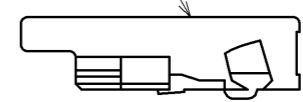

DIAGONAL ×

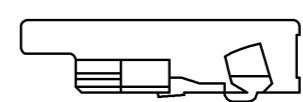

DF57-***SCF

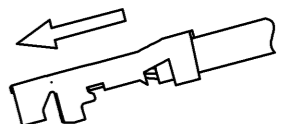
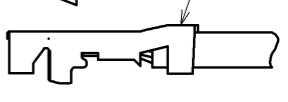

NOTE 1 AVOID ANGLED INSERTION OF CRIMP CONTACT(DF57-***SCF) TO MAINTAIN PERFORMANCE RELIABILITY.

NO.	MATERIAL	FINISH . REMARKS	NO.	MATERIAL	FINISH . REMARKS			
			1	PBT	UL94V-0. NATURAL(WHITE)			
UNITS	mm	SCALE	20 : 1	COUNT	DESCRIPTION OF REVISIONS	DESIGNED	CHECKED	DATE
HRS HIROSE ELECTRIC CO., LTD.		APPROVED	: KI. AKIYAMA	12.03.19	DRAWING NO.	EDC3-343900-00		
		CHECKED	: HK. UMEHARA	12.03.19	PART NO.	DF57H-2S-1.2C		
		DESIGNED	: TS. KUMAZAWA	12.03.19	CODE NO.	CL666-0100-6-00		
		DRAWN	: TS. KUMAZAWA	12.03.19		1/2		

DF57 Series Mating / Unmating Operation Instruction

Mating

① By positioning the convexity of the socket sides to the header concavity, align the centers of the socket and the header in pitch direction.

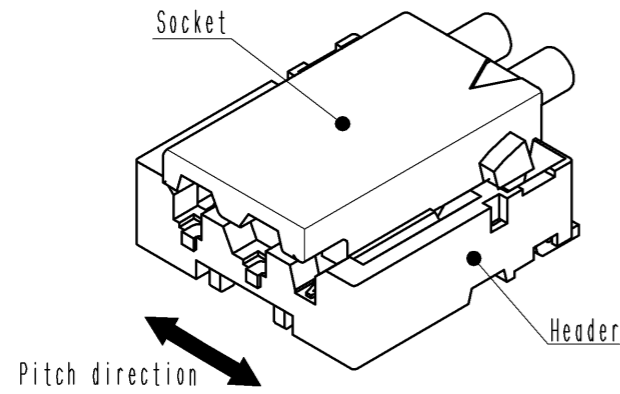

② Slightly press the socket down at cable side to tilted angle.

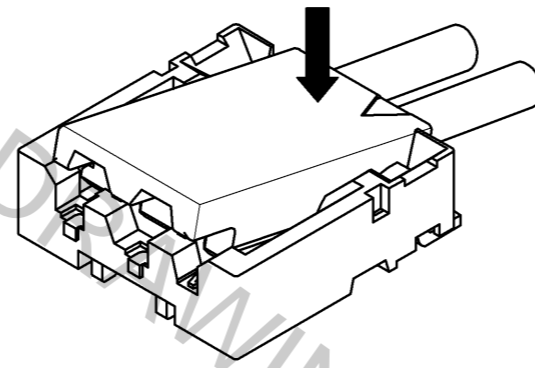

③ Press down at the lever side with stabilizing the cable side to insert. Mating completes.

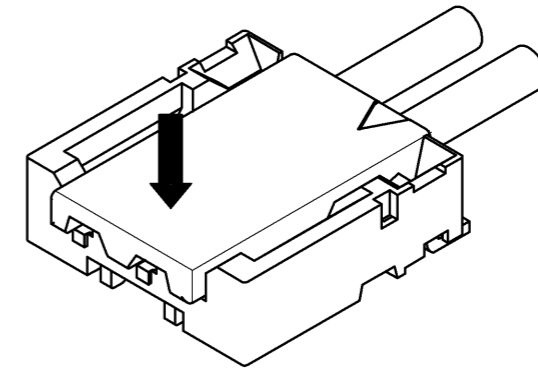

Unmating

① Hook the lever with finger nail.

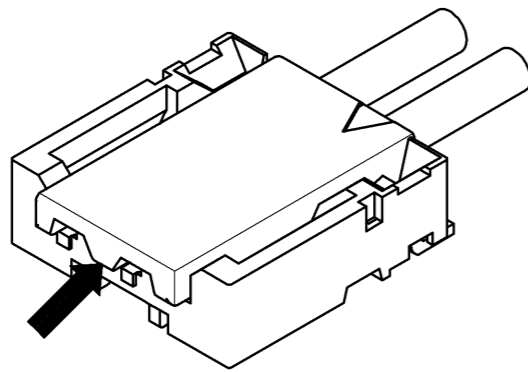

② Lift up to the upper direction and friction lock is released.

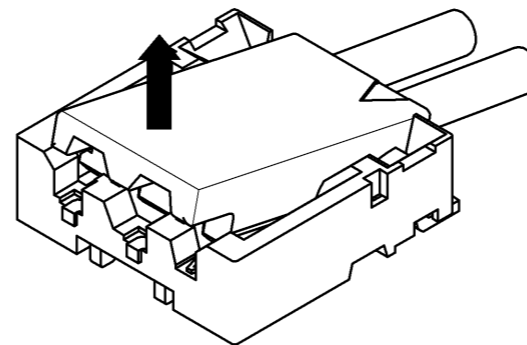

③ Lift up to the upper direction and positive lock is released. Removal completes.

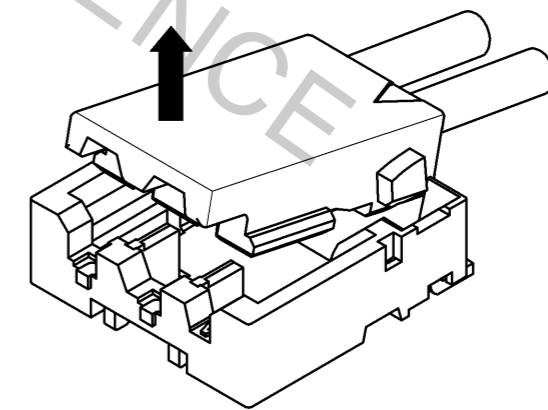

HRS	DRAWING NO.	EDC3-343900-00	△ 2/2
	PART NO.	DF57H-2S-1.2C	
	CODE NO.	CL666-0100-6-00	