

7-16

Surge Arrester
Jack - Jack

60BK565-KXXXN1

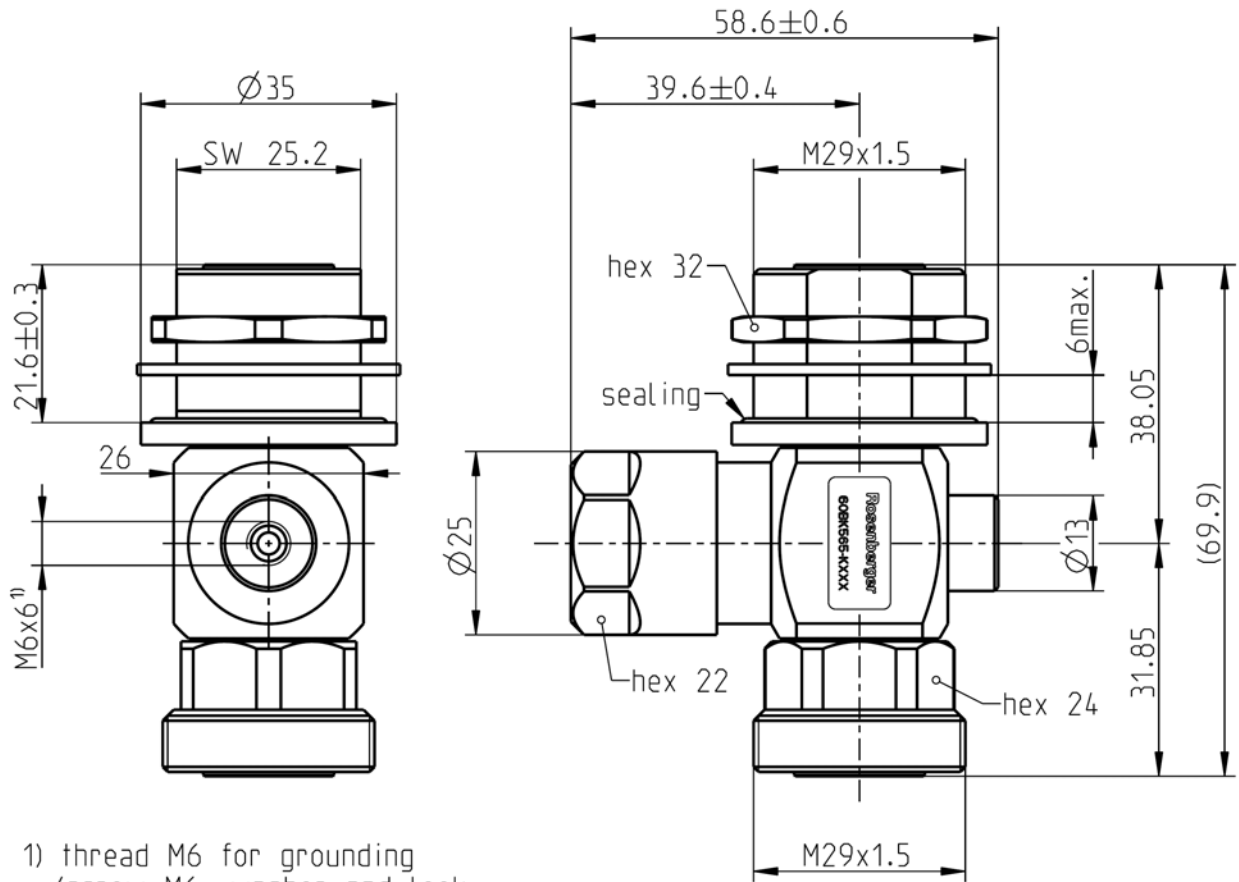

1) thread M6 for grounding
(screw M6, washer and lock washer not plotted)

All dimensions are in mm; tolerances according to ISO 2768 m-H

Order No	Nom. DC spark over voltage	Residual voltage (20kA 8/20 μs)	Residual voltage (4kV 1.2/50μs, 2kA 8/20 μs)	Residual energy (4kV 1.2/50μs, 2kA 8/20 μs)	Power handling (20 °C, sea level, VSWR 1.0)	Gas capsule
60BK565-K090N1	90 V	Tbd	Tbd	Tbd	1000 W	53ZB01-090
60BK565-K230N1	230 V	Tbd	Tbd	Tbd	5000 W	53ZB01-230
60BK565-K350N1	350 V	Tbd	Tbd	Tbd	10000 W	53ZB01-350

Interface

According to

IEC 61169-4, EN 122190, DIN 47223

Documents

Panel piercing (or PCB layout) (optional)

B 75

Dieses Dokument ist urheberrechtlich geschützt • This document is protected by copyright • Rosenberger Hochfrequenztechnik GmbH & Co. KG

RF_35/05.10/6.0

7-16

Surge Arrester
Jack - Jack

60BK565-KXXXN1

Material and plating

Connector parts

Center contact
Outer contact
Body
Dielectric
Gasket

Material

Spring bronze
Brass
Brass
PTFE
Silicone

Plating

Silver, 3-6 µm
White bronze(e.g. Optalloy®)
White bronze(e.g. Optalloy®)

Electrical data

Impedance 50 Ω
Frequency 698 to 2700 GHz
Return loss ≥ 21 dB @ 698 to 800 MHz
≥ 26 dB @ 800 to 960 MHz
≥ 21 dB @ 960 to 1700 MHz
≥ 26 dB @ 1700 to 2200 MHz
≥ 24 dB @ 2200 to 2500 MHz
≥ 21 dB @ 2500 to 2700 MHz
Insertion loss ≤ 0.1 dB
Insulation resistance ≥ 10 GΩ
Center contact resistance ≤ 0.4 mΩ
Outer contact resistance ≤ 1.5 mΩ
Intermodulation (3rd order) (optional) ≥ 160 dBc (2 x 43 dBm)

Mechanical data

Mating cycles ≥ 500
Center contact captivation: axial ≥ 200 N
radial ≥ 2 Ncm
Coupling torque (recommended) 25 to 30 Nm
Proof torque ≤ 35 Nm

Environmental data

Temperature range -45 °C to +85 °C
Rapid change of temperature DIN EN 122190, Sub-clause 4.6.7
Corrosion resistance DIN EN 122190, Sub-clause 4.6.10
Vibration DIN EN 122190, Sub-clause 4.6.3
Climatic category DIN EN 122190, Sub-clause 4.6.5 (55/155/56)
Damp heat DIN EN 122190 , Sub-clause 4.6.6
Degree of protection IEC 60529, IP68 2.5 bar
RoHS compliant

Weight

Weight 313.7 g/pce

While the information has been carefully compiled to the best of our knowledge, nothing is intended as representation or warranty on our part and no statement herein shall be construed as recommendation to infringe existing patents. In the effort to improve our products, we reserve the right to make changes judged to be necessary.

Draft	Date	Approved	Date	Rev.	Engineering change number	Name	Date
H.Schütt	23.03.11	Sa. Krautenbacher	20.03.14	400	14-0352	T. Krojer	20.03.14
Rosenberger Hochfrequenztechnik GmbH & Co. KG P.O.Box 1260 D-84526 Tittmoning Germany www.rosenberger.de					Tel. : +49 8684 18-0 Fax : +49 8684 18-499 Email : info@rosenberger.de		Page 2 / 2