

TOSHIBA CD Process Integrated Circuit Silicon Monolithic

TC78S122FNG

PWM Chopper Type Dual-Stepping Motor Driver

The TC78S122FNG is a PWM chopper type dual-stepping motor driver.

Two stepping motor drivers can drive up to four brushed DC motors. Incorporating two pairs of H-bridge drivers, the TC78S122FNG can drive two DC motors or a single stepping motor.

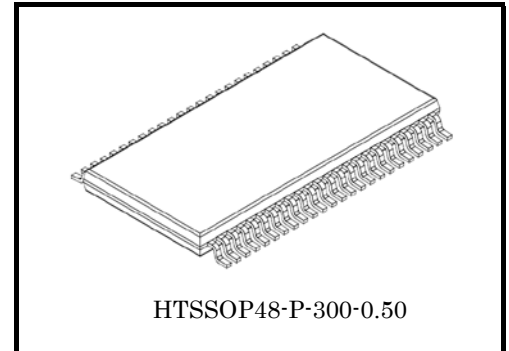

HTSSOP48-P-300-0.50

Weight: 0.212 (g)

Features

- Single-chip motor driver for bipolar stepping motor control
- Monolithic IC structured by CD process.
- Low ON-resistance: $R_{on} = 0.6 \Omega$
In large mode, ON-resistance of combined H-bridges is: $R_{on} = 0.3 \Omega$
- Over-current detection (ISD), thermal shutdown (TSD) and V_M power-on reset circuits
- Since the IC incorporates a V_{CC} regulator for internal circuit operation, an external power supply (5 V) is not required.
- Package: HTSSOP48
- Maximum output withstand voltage: 40 V (max)
- Output current: 2.0 A (max) in DC Motor (S) mode; 1.5 A (max) in Stepping Motor (S) mode
- Chopping frequency can be set by external capacitor and resistor. High-speed chopping is possible at 100 kHz or higher.

Block Diagram(Stepping Motor(S) × 2-Axis Control Mode)

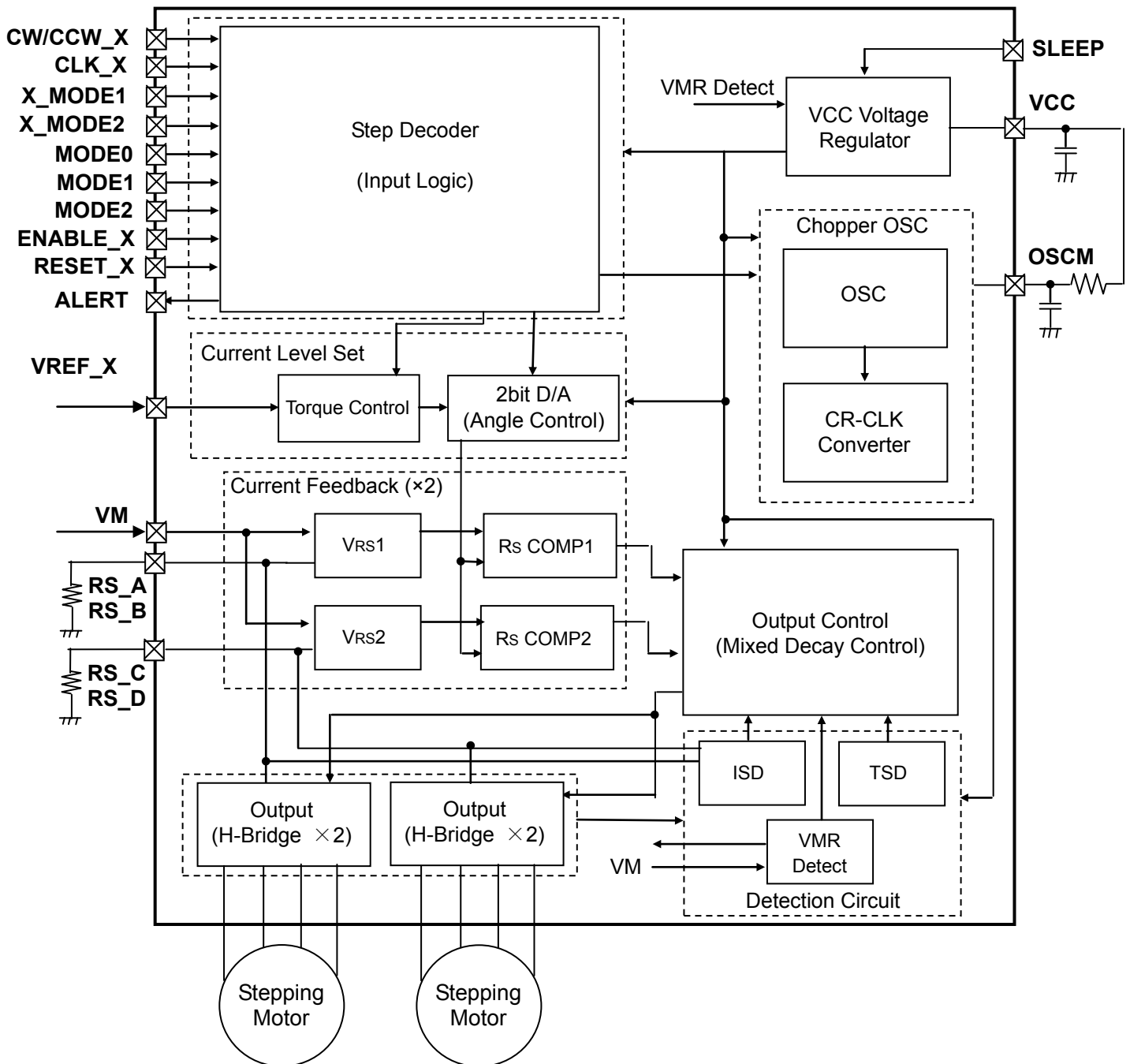

* "X" means the ellipsis of AB / CD of each
 Ch.(CW/CCW_X,CLK_X,X_MODE1,X_MODE2,ENABLE_X,RESET_X)

Note: GND wiring: We recommend that a heat sink be grounded at all points, and the board be grounded at only one GND pin for single point ground. Take the heat dissipation into consideration when designing the board. When in controlling the setting pins for each mode by SW, those pins should be pulled up to power supply like V_{CC} or pulled down to GND not to go into a high-impedance (Hi-Z) state. Utmost care is necessary in the design of the output line, V_M line and GND line since IC may be destroyed due to short-circuit between outputs, to supply, or to ground. Especially for those pins that are connected to power supply and get a large current flow (such as V_M, RS, OUT and GND), they should be properly wired; otherwise troubles including destruction may occur to this IC. If the logic input pins are not wired properly, malfunction that would destroy the IC may occur due to a large current exceeding the absolute maximum ratings. Care should be taken in the design of board layouts and implementation of the IC.

Pin Assignment

PIN No.	Pin name	(1)Stepper(S) × 2	(2)DC(L) × 2	(3)Stepper(L)	(5)DC(S) × 4	(5)DC(L)+Stepper(S)	(6)DC(S) × 2 + Stepper(S)
1	VM	VM power input pin					
2	VM	VM power input pin					
3	SLEEP	Sleep pin					
4	ALERT	Alert pin					
5	CLK_AB	ABch CLK input	ABch PWM pin	CLK input	Ach PWM pin	ABch PWM pin	Ach PWM pin
6	ENABLE_AB	ABch ENABLE input	-	ENABLE input	Bch PWM pin	-	Bch PWM pin
7	CLK_CD	CDch CLK input	CDch PWM pin	-	Cch PWM pin	CDch CLK input	CDch CLK input
8	ENABLE_CD	CDch ENABLE input	-	-	Dch PWM pin	CDch ENABLE input	CDch ENABLE input
9	OUT_A-	Ach output pin(-)	ABch output pin(-)	-	Ach output pin(-)	ABch output pin(-)	Ach output pin(-)
10	RS_A	Ach sensing Rs connection pin	ABch sensing Rs connection pin	-	Ach sensing Rs connection pin	ABch sensing Rs connection pin	Ach sensing Rs connection pin
11	RS2_A			-	Rs connection pin	Rs connection pin	Rs connection pin
12	OUT_A+	Ach output pin(+)	ABch output pin(+)	-	Ach output pin(+)	ABch output pin(+)	Ach output pin(+)
13	OUT_B+	Bch output pin(+)	ABch output pin(+)	-	Bch output pin(+)	ABch output pin(+)	Bch output pin(+)
14	RS2_B	Bch sensing Rs connection pin	ABch sensing Rs connection pin	-	Bch sensing Rs connection pin	ABch sensing Rs connection pin	Bch sensing Rs connection pin
15	RS_B			-	Rs connection pin	Rs connection pin	Rs connection pin
16	OUT_B-	Bch output pin(-)	ABch output pin(-)	-	Bch output pin(-)	ABch output pin(-)	Bch output pin(-)
17	D_TBLANK_AB	ABch Decay setting pin	TBLANK setting pin	-	TBLANK setting pin	TBLANK setting pin	TBLANK setting pin
18	D_TBLANK_CD	CDch Decay setting pin	TBLANK setting pin	Decay setting pin	TBLANK setting pin	TBLANK setting pin	CDch Decay setting pin
19	MODE2	"H" input fixed	"H" input fixed	"H" input fixed	"H" input fixed	"L" input fixed	"L" input fixed
20	NC	NC					
21	MODE1	"H" input fixed	"H" input fixed	"L" input fixed	"L" input fixed	"H" input fixed	"H" input fixed
22	MODE0	"H" input fixed	"L" input fixed	"H" input fixed	"L" input fixed	"H" input fixed	"L" input fixed
23	VM	VM power input pin					
24	VM	VM power input pin					
25	CW/CCW_AB	ABch CW/ CCW pin	ABch IN 2 pin	CW/ CCW pin	Ach IN 2 pin	ABch IN 2 pin	Ach IN 2 pin
26	MO_AB	ABch MO pin	ABch IN 1pin	MO pin	Ach IN 1 pin	ABch IN 1 pin	Ach IN 1 pin
27	AB_MODE2	ABch step resolution mode setting	-	Mode setting	Bch IN 2 pin	-	Bch IN 2 pin
28	AB_MODE1	ABch step resolution mode setting	-	Mode setting	Bch IN 1 pin	-	Bch IN 1 pin
29	NC	NC					
30	CW/CCW_CD	CDch CW/ CCW pin	CDch IN 2 pin	-	Cch IN 2 pin	CDch CW/ CCW pin	CDch CW/ CCW pin
31	MO_CD	CDch MO pin	CDch IN 1 pin	-	Cch IN 1 pin	CDch MO pin	CDch MO pin
32	CD_MODE2	CDch step resolution mode setting	-	-	Dch IN 2 pin	-	CDch step resolution mode setting
33	OUT_C-	Cch output pin(-)	CDch output pin(-)	-	-	Cch output pin(-)	Cch output pin(-)
34	RS_C	Cch sensing Rs connection pin	CDch sensing Rs connection pin	-	Cch sensing Rs connection pin		
35	RS2_C			-	Cch sensing Rs connection pin		
36	OUT_C+	Cch output pin(+)	CDch output pin(+)	-	Cch output pin(+)		
37	OUT_D+	Dch output pin(+)	CDch output pin(+)	-	Dch output pin(+)		
38	RS2_D	Dch sensing Rs connection pin	CDch sensing Rs connection pin	-	Dch sensing Rs connection pin		
39	RS_D			-	Dch sensing Rs connection pin		
40	OUT_D-	Dch output pin(-)	CDch output pin(-)	-	Dch output pin(-)		
41	CD_MODE1	CDch step resolution mode setting	-	-	Dch IN 1 pin	CDch step resolution mode setting	CDch step resolution mode setting
42	VREF_A	Ach Vref input	ABch Vref input	-	Ach Vref input	ABch Vref input	Ach Vref input
43	VREF_B	Bch Vref input	-	-	Bch Vref input	-	Bch Vref input
44	VREF_C	Cch Vref input	CDch Vref input	-	Cch Vref input	Cch Vref input	Cch Vref input
45	VREF_D	Dch Vref input	-	-	Dch Vref input	Dch Vref input	Dch Vref input
46	OSCM	Setting pin of oscillation circuit frequency for chopping					
47	VGC	Monitoring pin for internal generated 5V bias					
48	GND	GND					

* When Large mode is used, please use to connect the corresponding pins to each other.

■Descriptions of Motor Drive Modes

- (1) Stepping Motor (S) × 2 control mode pin name and assignment
- (2) DC Motor (L) × 2 control mode pin name and assignment
- (3) Stepping Motor (L) × 1 control mode pin name and assignment
- (4) DC Motor (S) × 4 control mode pin name and assignment
- (5) Stepping Motor (S) × 1 control mode + DC Motor (L) × 1 control mode pin name and assignment
- (6) Stepping Motor (S) × 1 control mode + DC Motor (S) × 2 control mode pin name and assignment

* In the modes that include DC Motor (S) mode, the digital tBLANK time can be separately set for each axis pair, axes A and B and axes C and D.

Axes A and B: D_TBLANK_AB pin

Axes C and D: D_TBLANK_CD pin

The motor drive Mode(2, 1, 0)= (L, L, H) is provided only for Toshiba testing and must not be used during normal operation.

Note 1: In Combination mode, such as Stepping Motor (L) and DC Motor (L) modes, the impedance outside the IC should be balanced.

Note 2: In large mode, if the impedance of wiring to mutually connected output transistors is unbalanced, the current that flows through the transistor also becomes unbalanced and may exceed the absolute maximum rating of the transistor, thus permanently damaging the transistors.

■H-bridge Combination (connection method) for Each Type of Motor Driver

- Stepping Motor (S) Combination

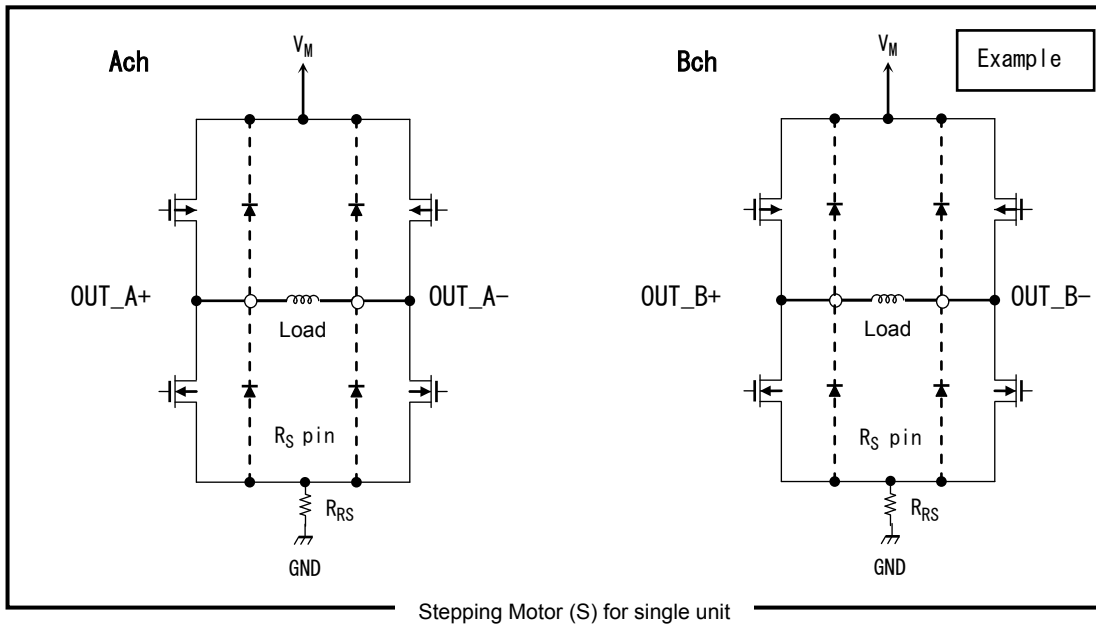

- DC Motor (S) Combination

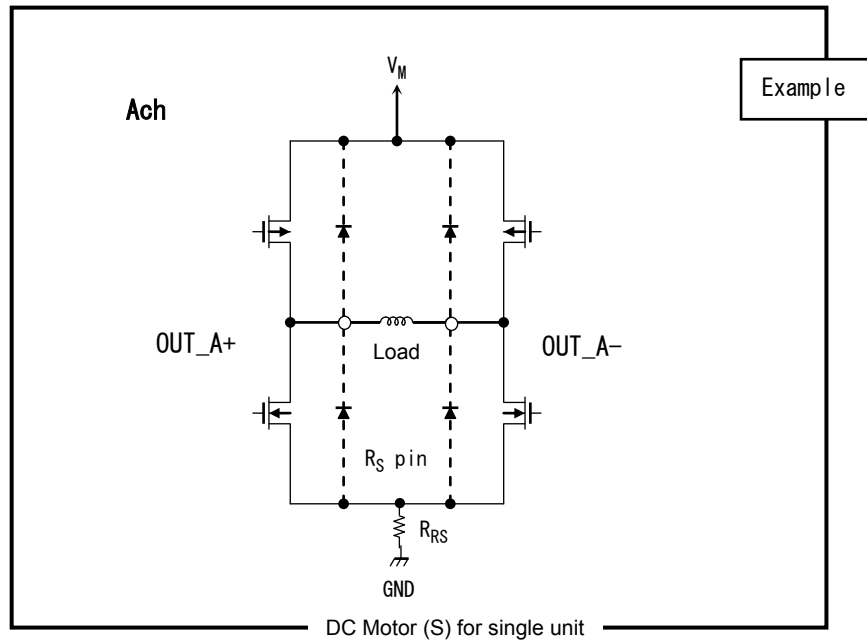

○ ...Indicates an IC output pin connected to a motor.

- Stepping Motor (L) Combination

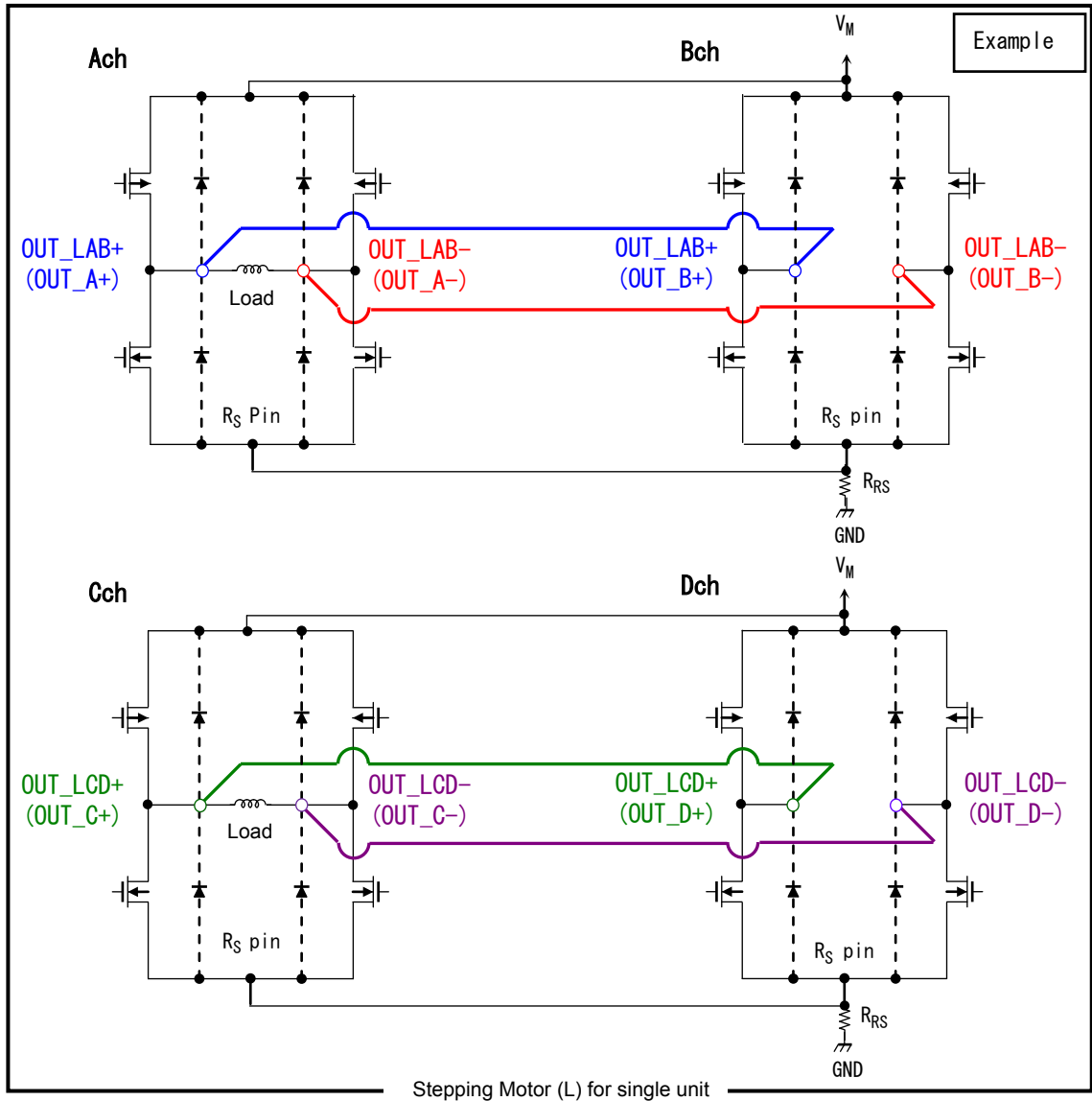

DC Motor (L) Combination

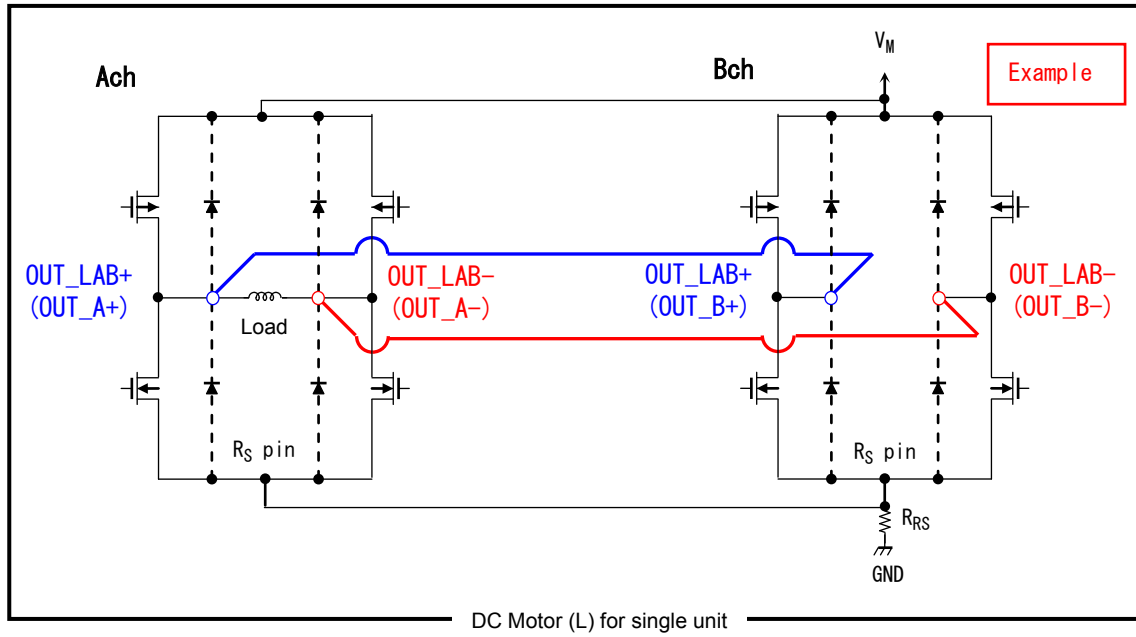

○ ...Indicates an IC output pin connected to a motor.

Output Control Circuit, Current Feedback Circuit, and Current Setting Circuit for Motor Driver

Note: Logic input pins are internally connected to pull-down resistors of about 100 kΩ.

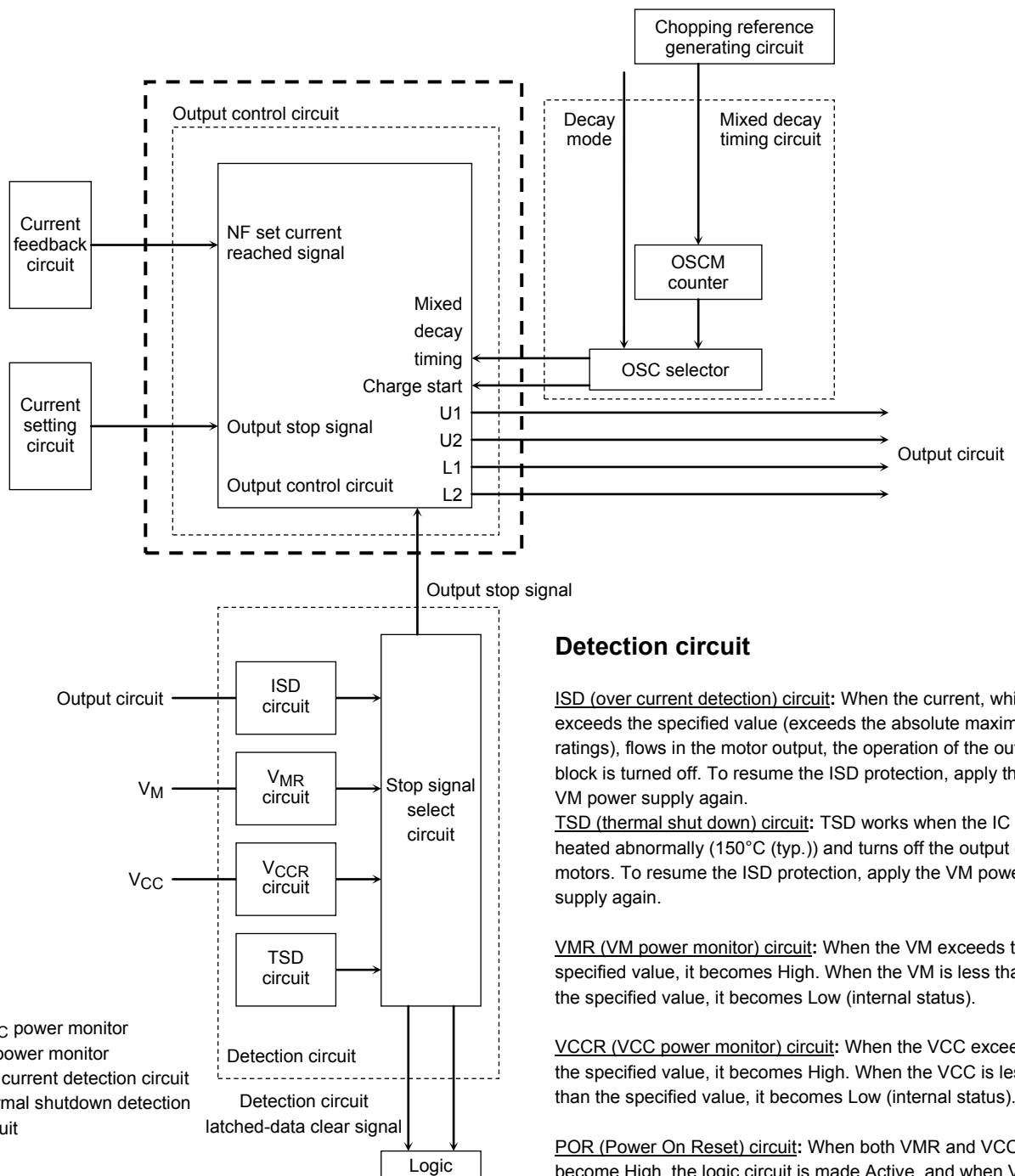

VCCR: VCC power monitor
 VMR: VM power monitor
 ISD: Over current detection circuit
 TSD: Thermal shutdown detection circuit

Output Equivalent Circuit of A/B-unit (C/D-unit conforms to A/B-unit.)

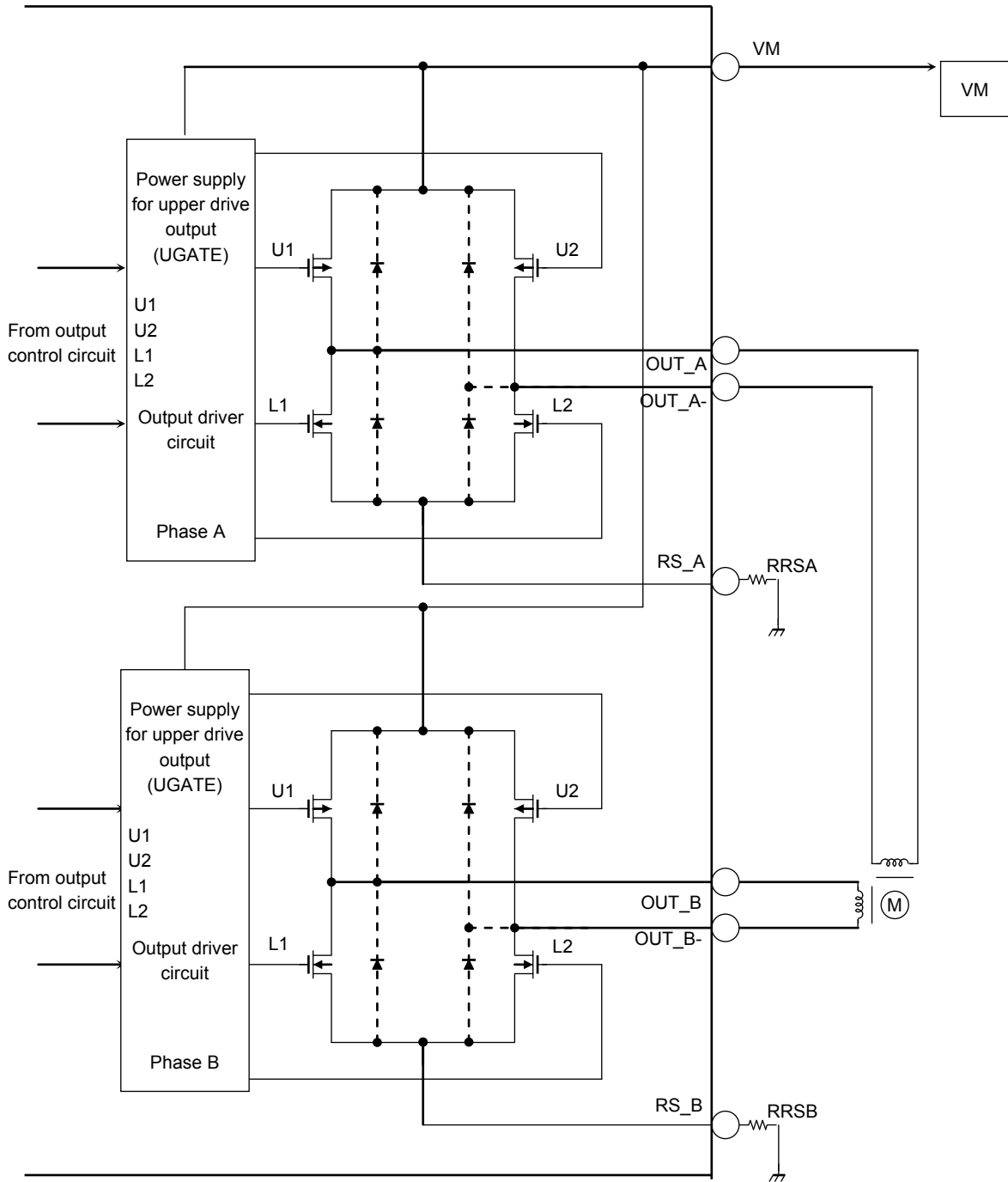

1. Function Table for Motor Drive Mode Selection

Motor drive modes can be selected depending on the type of motors to be driven.

The configuration of H-bridge drivers and control category are changed according to the selected mode.

There is basically no need to change drive modes during motor operation. Thus, the TC78S122FNG does not support dynamic mode switching.

Changing the settings of these pins changes the functions and timing of control pins.

The setting of mode select pins must not be changed after the TC78S122FNG is powered on.

Mode 0	Mode 1	Mode 2	Drive Mode
H	H	H	Stepping Motor (S) × 2
L	H	H	DC Motor (L) (Combination) × 2
H	L	H	Stepping Motor (L) (Combination) × 1
L	L	H	DC Motor (S) × 4
H	H	L	DC Motor (L) (Combination) × 1 + Stepping Motor (S)
L	H	L	DC Motor (S) × 2 + Stepping Motor (S)
H	L	L	Inhibited (For Toshiba testing only)
L	L	L	Standby mode

- **Stepping Motor Mode**
 This mode is used to drive stepping motors.
 The tBLANK time is specified as a fixed analog value (about 300 ns).
 Each motor is controlled via two logic control inputs, PHASE (current direction) and ENABLE (ON/OFF), and via the Vref input for constant-current control.
- **Brushed DC Motor Mode**
 This mode is used to drive brushed DC motors.
 The tBLANK time can be specified as a fixed analog value, or as four OSC cycles in digital tBLANK mode, where OSC is a reference signal for chopper circuit.
 When DC motors are driven under PWM control, a discharge current spike can occur due to a varistor. To prevent this current spike from erroneously tripping the constant-current sensor, the constant-current sensor is digitally blanked for a period of time that is determined by tBLANK, which is derived from the OSC signal.
 Using this blanking function enables constant-current limiter control, as well as external PWM control. An over-current can be observed only during blank times.
- **Combination Mode**
 The Combination mode, such as DC Motor (L) and Stepping Motor (L) modes, can be selected when two units of H-bridges with the same characteristics are operated in parallel.
 In this mode, the actual ON-resistance is reduced by half while the current capability is doubled. (Specifications actually include the thermal capacitance as well. See electrical characteristics for more details.)
 To use this mode, the power supply, ground, and output pins that have identical names should be shorted together on the board.
 At the same time, the wirings of a board should be routed to balance the impedance at each pin. Otherwise, the shorted pins may experience a current imbalance and more current may flow into either one of them than the other.

2. Stepping Motor mode Function

(1) CLK Function

The electrical angle leads one by one in the manner of the clocks. The clock signal is reflected to the electrical angle on the rising edge.

CLK_AB CLK_CD	Function
Rise	The electrical angle leads one by one on the rising edge.
Fall	Remains at the same position.

(2) ENABLE Function

The ENABLE pin controls whether the current is allowed to flow through a given phase for a stepper motor drive. This pin selects whether the motor is stopped in Off mode or activated. The pin should be fixed to Low at power-on or power-down of the TC78S122FNG.

ENABLE_AB ENABLE_CD	Function
H	Output transistors are enabled (normal operation mode).
L	Output transistors are disabled (high impedance: Z).

(3) CW/CCW Function and output pin function (Output logic at charge starting)

The CW/CCW pin switches rotation direction of stepping motors.

CW/CCW_AB CW/CCW_CD	Input function	OUT (+)	OUT (-)
X	L	OFF	OFF
H	Clock-wise	H	L
L	Counter clock-wise	L	H

X: Don't care

(4) Step resolution Mode Select Function

AB_MODE1 CD_MODE1	AB_MODE2 CD_MODE2	Function
L	L	Fixed electrical angle (Initial setting of Full step: 45°)
L	H	Half step
H	L	Full step
H	H	Quarter step

In the case of AB/CD_MODE1=L, and AB/CD_MODE2=L, the electrical angle is reset and fixed to 45°, which is the initial value in the full step mode.

3. D_TBLANK Function (DC Motor MODE only)

D_TBLANK_AB D_TBLANK_CD	Motor Drive Mode
L	OFF: Digital tBLANK Time = OSC×0
H	ON: Digital tBLANK Time = OSC×4

* If it is set to "L", only analog tBLANK width can be available.

4. Decay Switching Function (Stepping Motor MODE only)

D_TBLANK_AB D_TBLANK_CD	Constant current control mode
L	Mixed Decay:37.5% fixed
H	Mixed Decay:12.5%(During the current decay is 37.5%)

5. Control Signal Functions in Brushed DC Motor Mode

Control Input			State of the Output Stage		
MO_X X_MODE1	CW/CCW_X X_MODE2	CLX_X ENABLE_X	OUT_X+	OUT_X-	Mode
H	H	H	L	L	Short brake
		L			
L	H	H	L	H	Forward/reverse
		L	L	L	Short brake
H	L	H	H	L	Reverse/forward
		L	L	L	Short brake
L	L	H	OFF (Hi-z)	OFF (Hi-z)	Stop
		L			

* "X" means the ellipsis of AB / CD of each Ch.(CW/CCW_X, X_MODE1, X_MODE2, MO_X, CLX_X and ENABLE_X)

- **External PWM Control Function**

The motor speed can be controlled by applying 0V and 5V (higher than TTL level) PWM signals to the PWM pin.

In PWM mode, the PWM chopper circuit alternates between on and short brake.

When the PWM speed control is not required, the PWM pin (short brake pin) should be held High.

When the constant-current limiter is used, the TC78S122FNG enters 37.5% Mixed Decay mode after an output current reaches the predefined current value. Since the dead band time is internally inserted to prevent a shoot-through current eliminating, the special arrangement is not required.

The short brake function is disabled in Stepping Motor mode (Large or Small).

Stepping motors can also be driven in Brushed DC motor mode.

To perform such operation, the short brake function should not be used and the D_TBLANK pin should be set Low.

At the same time, input signal functions should also be confirmed.

6. SLEEP Function

To control the SLEEP pin, you can control a low power consumption mode (VCC OFF) and the normal operation mode (VCC ON).

When SLEEP pin is Low, VCC regulator is turned OFF, completely logic will stop.

SLEEP pin is High after the input, it can return to the normal operation mode in 1ms.

SLEEP	Function
L	low power consumption mode (VCC OFF)
H	normal operation mode (VCC ON)

7. ALERT Function

The ALERT pin will show “Low” level when an error occasion (TSD/ISD) is detected.

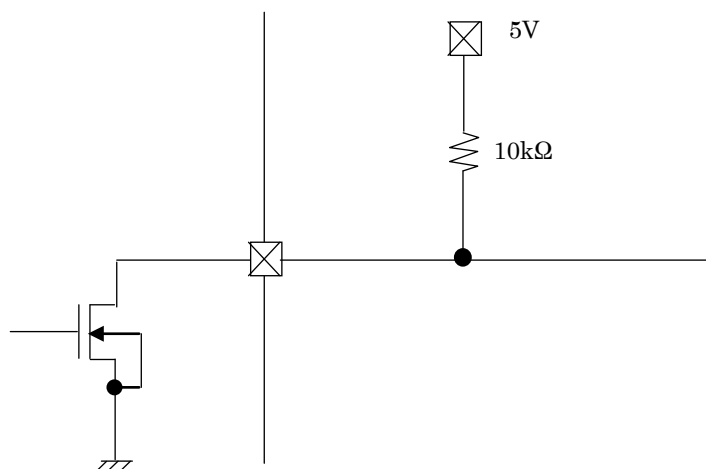

The ALERT is an open drain output pin. When the output pin is pulled up to the VCC with resistance, the Low is output (MOSFET ON) at the Reset, and the High (internal Hi-Z) is output at the non-reset. Please connect with pull-up to the VCC.

Absolute Maximum Ratings (Ta=25°C)

Characteristics	Symbol	Rating	Unit	Remarks
Motor power supply	VM	40	V	
Motor output voltage	VOUT	40	V	
Motor output current (Note 1)	IOUT_(ST_S)	2.0	A	
	IOUT_(ST_L)	3.0	A	
	IOUT_(DC_S)	3.5	A	(tw ≤ 500ns)
	IOUT_(DC_L)	5.0	A	(tw ≤ 500ns)
Internal Logic power supply	VCC	6.0	V	
Logic input voltage	VIN(H)	6.0	V	
	VIN(L)	-0.4	V	
Power dissipation (single) (Note 2)	PD	1.3	W	
Operating temperature	TOPR	-20 to 85	°C	
Storage temperature	TSTR	-55 to 150	°C	
Junction temperature	Tj(max)	150	°C	

Note 1: As a guide, the maximum output current should be kept below 1.4 A per phase. The maximum output current may be further limited in view of thermal considerations, depending on ambient temperature and board conditions.

Note 2: Stand-alone (Ta =25°C)
When Ta exceeds 25°C, it is necessary to do the derating with 10.4mW/°C.

Ta: Ambient temperature

Topr: Ambient temperature while the TC78S122FNG is active

Tj: Junction temperature while the TC78S122FNG is active. The maximum junction temperature is limited by the thermal shutdown (TSD) circuitry.

It is advisable to keep the maximum current below a certain level so that the maximum junction temperature, Tj (MAX), will not exceed 120°C.

Caution) Absolute maximum ratings

The absolute maximum ratings of a semiconductor device are a set of ratings that must not be exceeded, even for a moment. Do not exceed any of these ratings.

Exceeding the rating (s) may cause device breakdown, damage or deterioration, and may result in injury by explosion or combustion.

The value of even one parameter of the absolute maximum ratings should not be exceeded under any circumstances. The TC78S122FNG does not have overvoltage detection circuit. Therefore, the device is damaged if a voltage exceeding its rated maximum is applied.

All voltage ratings, including supply voltages, must always be followed. The other notes and considerations described later should also be referred to.

Operation Ranges(Ta=0 to 85°C)

Characteristics	Symbol	Test Circuit	Test Condition	Min	Typ.	Max	Unit
Internal logic power supply voltage	VCC	DC	(Automatically generated)	4.5	5.0	5.5	V
Motor power supply voltage	VM	DC	—	8	24	38	V
Motor output current	I _{out} (ST_S)	DC	Ta = 25°C per phase	—	0.8	1.5	A
	I _{out} (ST_L)	DC	Ta = 25°C per phase	—	1.5	2.1	
	I _{out} (DC_S)	DC	Ta = 25°C per phase	—	1.0	2.0	
	I _{out} (DC_L)	DC	Ta = 25°C per phase	—	2.0	3.8	
Logic input voltage	VIN	DC	—	GND	3.3	5.0	V
Chopping frequency setting range	fchop	DC	VCC=5.0V	40	100	150	kHz
Vref voltage	Vref	DC	VM=24V	GND	3.0	4.0	V
Current detect pin voltage	VRS	DC	VM=24V	0	±1.0	±1.5	V

Note: Use the maximum junction temperature (T_j) at 120°C or less. The Maximum current cannot be used under certain thermal conditions.

Electrical Characteristics 1 (Unless otherwise specified, Ta=25°C V_M=24 V)

Characteristics		Symbol	Test Circuit	Test Condition	Min	Typ.	Max	Unit
Logic input voltage (Other than SLEEP pin)	High	V _{IH}	DC	Logic input pins (Other than SLEEP pin)	2.2	—	5.5	V
	Low	V _{IL}			GND	—	0.8	
Logic input voltage (SLEEP pin only)	High	V _{IH}	DC	SLEEP pin only	2.0	—	5.5	V
	Low	V _{IL}			GND	—	0.6	
Logic input hysteresis voltage		H _{is}	DC	Logic input pins	0.3	0.4	0.5	V
Logic input current		I _{IN} (H)	DC	V _{IN} =5V, Input pins with resistor	—	50	75	μA
		I _{IN} (L)			—	—	1	
MO,ALERT output voltage		V _{OL}	DC	I _{OL} =4mA output:Low	—	—	0.5	V
Current consumption (V _M pin)		IM1	DC	Output=OPEN (ENABLE ALL=L), MOSFET=OFF	—	2	3	mA
		IM2		Output=OPEN, f _{PWM} =100kHz Logic operate, MOSFET=OFF	—	3.5	5	
		IM3		Output=OPEN Function mode(Full step)	—	8	10	
		IM4		SLEEP=L VCC regulator = OFF	—	10	20	μA
Output leakage current	Upper side	I _{OH}	DC	VM=24V, V _{out} =0V, ENABLE ALL=L	-1	—	—	μA
	Lower side	I _{OL}		VM=V _{out} =24V, ENABLE ALL=L	—	—	1	μA
Output current differential		ΔI _{out1}	DC	I _{out} =1.0A	-5	—	5	%
Output current setting differential		ΔI _{out2}	DC	I _{out} =1.0A	-5	—	5	%
RS pin current		I _{RS}	DC	V _{RS} =0V, V _M =24V, ENABLE ALL=L (MOSFET = OFF)	—	—	10	μA
Output transistor drain-source ON-resistance (H-side + L-side)		R _{on} (DS: H-side + L-side) S	DC	I _{out} =1.0A, T _j =25°C, Drain-source, (Upper + Lower) Small Mode	0.4	0.6	0.8	Ω
		R _{on} (DS: H-side + L-side) L		I _{out} =1.0A, V _{CC} =5.0V, T _j =25°C, Drain-source, (Upper + Lower) Large Mode	—	0.3	0.4	

Electrical Characteristics 2 (Unless otherwise specified, Ta=25°C, VM=24 V)

Characteristics	Symbol	Test Circuit	Test Condition	Min	Typ.	Max	Unit
V _{ref} input voltage	VREF	DC	VM=24V, VCC=5V	GND	3.0	4.0	V
V _{ref} input current	IREF	DC	VREF=3.0V	—	0	1	μA
VCC output voltage	VCC	DC	ICC=5.0mA	4.5	5.0	5.5	V
VCC output current	ICC	DC	VCC=5.0V	—	2.5	5	mA
V _{ref} attenuation ratio	VREF(gain)	DC	VREF=2.0V	1/5.2	1/5.0	1/4.8	—
TSD temperature (Note 1)	TJTSD	DC	—	140	150	170	°C
V _M return voltage	VMR	DC	—	6.8	7.0	7.3	V
Detection current of over-current detection circuit (Note 2)	ISD	DC	—	2.1	4.0	5.0	A

Note 1: Thermal shut down (TSD) circuit

When the IC junction temperature reaches the specified value and become overheated under irregular conditions causing the TSD circuit to be activated, the internal halt circuit is activated shutting down all the outputs to off. When the temperature is set between 140 °C (min) to 170 °C (max), the TSD circuit operates (design target value). When the TSD circuit is operating, it can be returned by re-starting the VM power supply or setting the standby mode. The TSD function aims at detecting abnormal heating of ICs. Please avoid positively using the TSD function.

Note 2: Over-current detection (ISD) circuit

When the current exceeding the specified value flows to the output under irregular conditions, the internal halt circuit is activated switching all the outputs to off. The dead band time is set to avoid the uncorrect operation by switching. (For details, refer to “ISD Dead Band Time and ISD Operating Time.”) When the ISD function is operating, the output is stopped until power-on-reset of the VM power supply. It can be returned by re-starting the VM power supply or setting the standby mode. The ISD function aims at detecting abnormal voltage of ICs. Please avoid positively using the ISD function.

Note 3: Even if the logic input signal is input in the state that the VM voltage is not supplied, although the circuit is designed so that electromotive force and leakage current by the signal input do not occur, please control the logic input signal so that the motor does not operate before re-supplying VM voltage.

Back-EMF

- While a motor is rotating, there is a timing at which power is fed back to the power supply. At that timing, the motor current is fed back to the power supply owing to the effect of the motor back-EMF. If the power supply does not have enough sink capability, the power supply and output pins of the device might rise above the rated voltages. The magnitude of the motor back-EMF varies with usage conditions and motor characteristics. It must be fully verified that there is no risk that the TC78S122FNG or other components will be damaged or fail owing to the motor back-EMF.

Cautions on Overcurrent Shutdown (ISD) and Thermal Shutdown (TSD)

- The ISD and TSD circuits are only intended to provide temporary protection against irregular conditions such as an output short circuit; they do not necessarily guarantee complete IC safety.
- If the device is used beyond the specified operating ranges, these circuits may not operate properly: then the device may be damaged owing to an output short circuit.
- The ISD circuit is only intended to provide temporary protection against an output short circuit. If such a condition persists for a long time, the device may be damaged owing to overstress. Overcurrent conditions must be removed immediately by external hardware.

IC Mounting

Do not insert devices in the wrong orientation or incorrectly. Otherwise, it may cause device breakdown, damage and/or deterioration.

AC Electrical Characteristics (Ta = 25°C, V_M = 24V, Load = 6.8 mH/5.7Ω)

Characteristics	Symbol	Test Circuit	Test Condition	Min	Typ.	Max	Unit
Logic input frequency	f _{Logic}	AC	—	1.0	—	200	kHz
CLK input internal filter width	t _{CLK(H)}	AC	—	300	—	—	ns
	t _{CLK(L)}			250	—	—	
Output transistor switching characteristic	t _r	AC	Output load: 6.8 mH/5.7 Ω	60	120	200	ns
	t _f			30	70	130	
	t _{pLH}		Between Signal to OUT Output load: 6.8 mH/5.7 Ω	—	120	500	
	t _{pHL}			—	120	500	
Noise rejection dead band time	t _{BLANK_AB(L)} t _{BLANK_CD(L)}	AC	I _{out} =0.6A, V _M =24V, Analog t _{BLANK} width	450	550	700	ns
	t _{BLANK_AB(H)} t _{BLANK_CD(H)}	AC	I _{out} =0.6A, OSC=1.6MHz, 4×OSC setting	2.0	2.5	3.0	μs
OSCM reference signal oscillation frequency	f _{OSCM}	AC	C _{osc} =270pF, R _{osc} =120kΩ	1200	1600	2000	kHz
Chopping frequency range	f _{chop}	AC	Output operation (I _{out} =1.0A)	40	100	150	kHz
Chopping frequency	f _{chop}	AC	Output operation (I _{out} =1.0A) OSC=1.6MHz	—	100	—	kHz

Decay Mode1:Charge to Slow to Fast

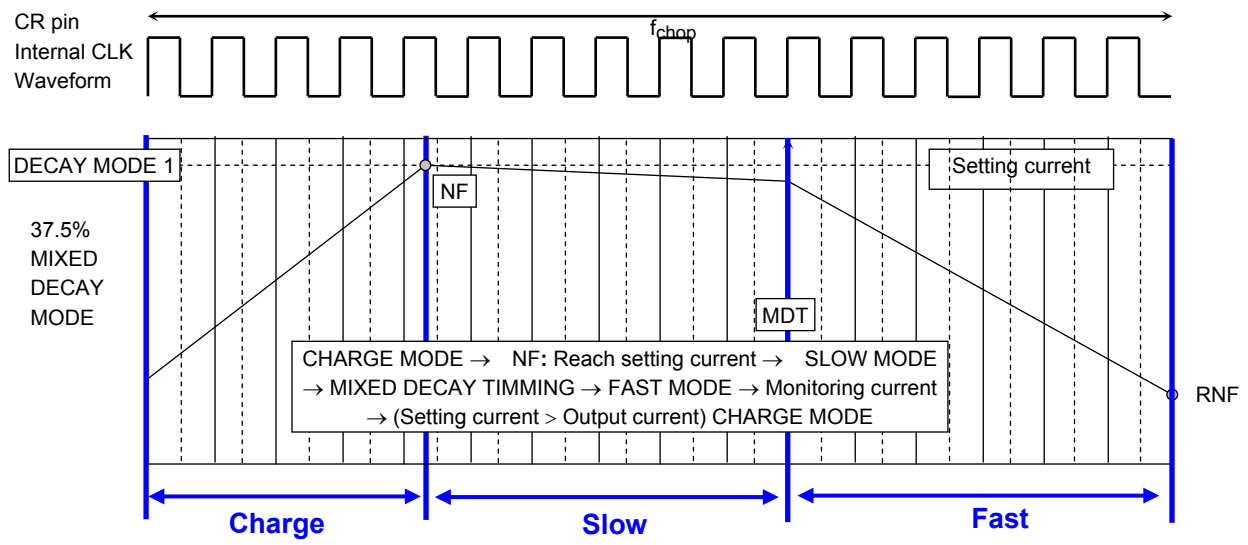

Mixed Decay Mode / Detecting zero point

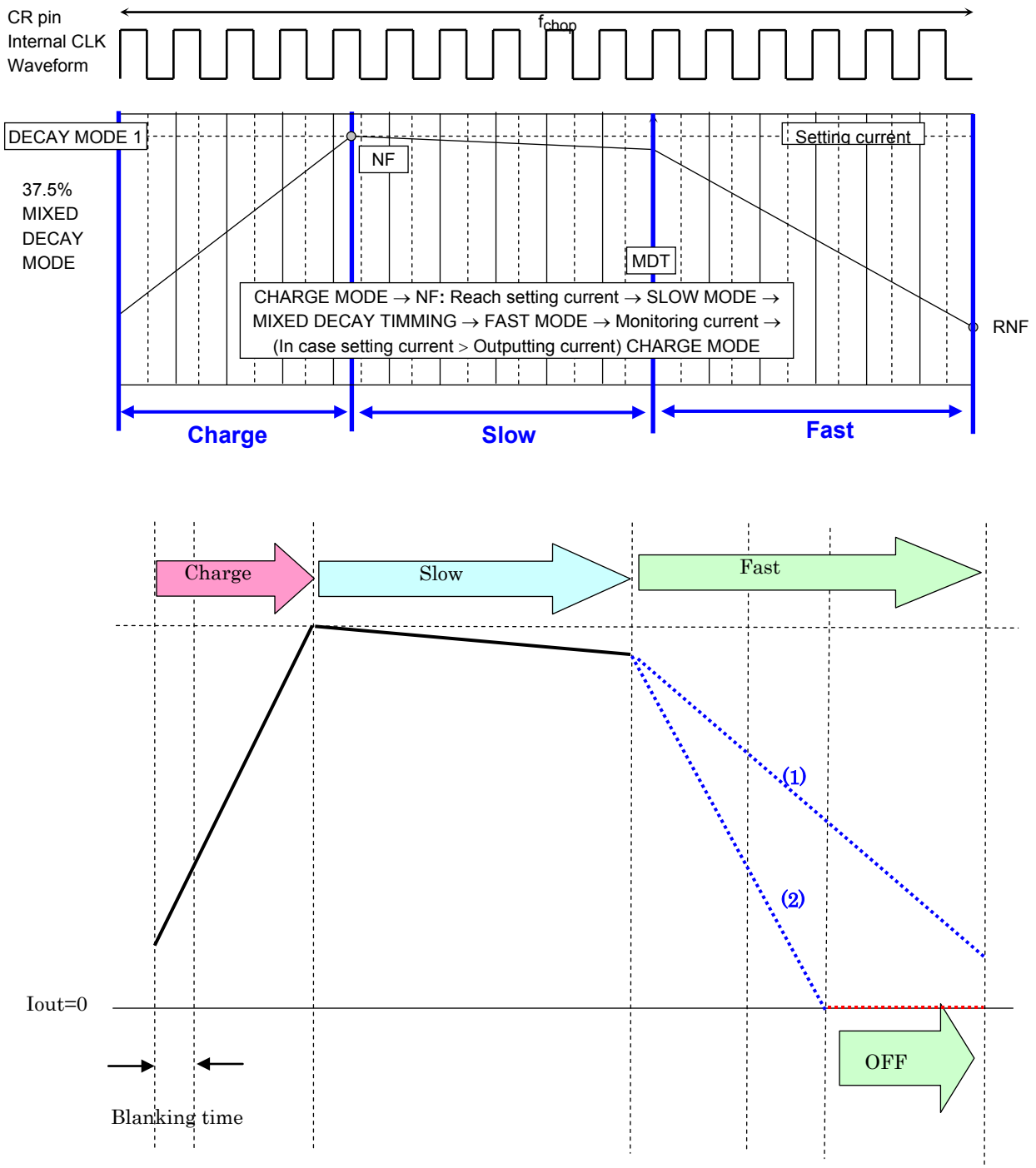

The [NF] shows the point of which the output current reaches the setting current value. The [Charge] shows the different value of the step resolution characteristics (such as inductance or resistance).

Status (1): When Fast->Charge operation starts before reaching zero point ($I_{out}=0A$)

Status (2): When reaching zero point ($I_{out}=0A$)

Mixed Decay mode: Charge->NF: Reaching setting current->Slow->Fast->Charge->...

Output Transistor Operating Modes

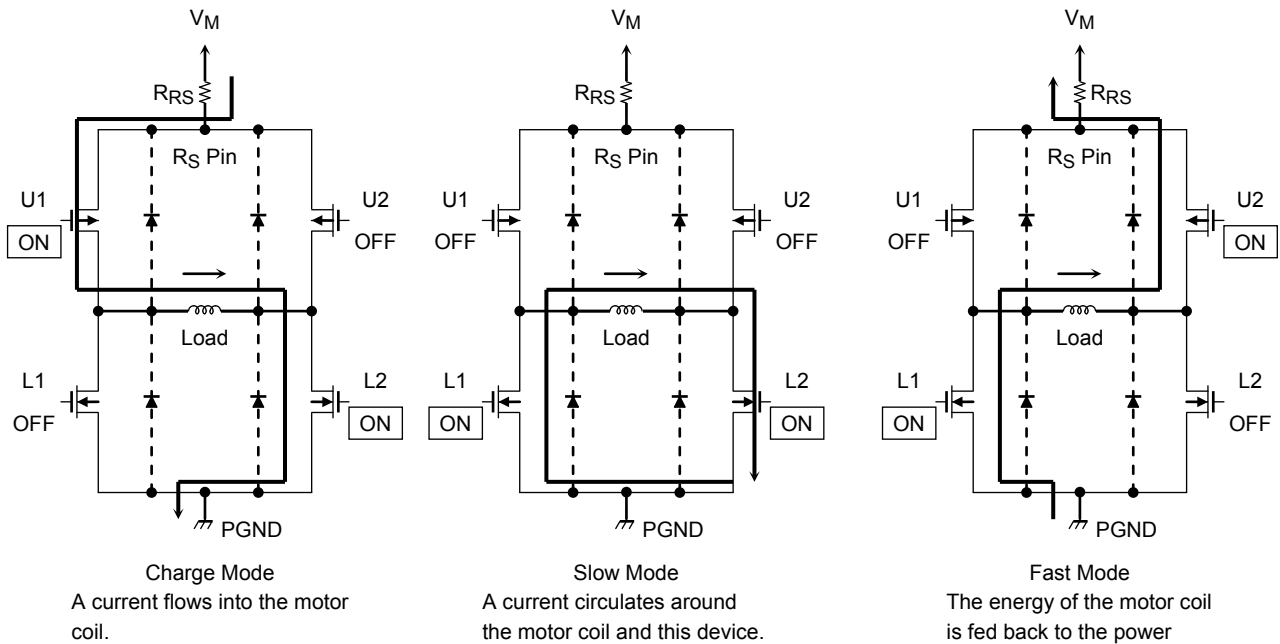

Output Transistor Operating Function

CLK	U1	U2	L1	L2
Charge Mode	ON	OFF	OFF	ON
Slow Mode	OFF	OFF	ON	ON
Fast Mode	OFF	ON	ON	OFF

Note: This table shows an example of when the current flows as indicated by the arrows in the figures shown above. If the current flows in the opposite direction, refer to the following table.

CLK	U1	U2	L1	L2
Charge Mode	OFF	ON	ON	OFF
Slow Mode	OFF	OFF	ON	ON
Fast Mode	ON	OFF	OFF	ON

The TC78S122FNG switches among Charge, Slow-Decay and Fast-Decay modes automatically for constant-current control. The equivalent circuit diagrams may be simplified or some parts of them may be omitted for explanatory purposes.

Calculation of the Setting Output Current

For PWM constant-current control, the TC78S122FNG uses a clock generated by OSCM oscillator. The peak output current can be set via the current-sensing resistor (R_{RS}) and the reference voltage (V_{ref}), as follows:

$$I_{out(Max)} = V_{ref(gain)} \times \frac{V_{ref(V)}}{R_{RS}(\Omega)}$$

$V_{ref(gain)}$: V_{ref} decay ratio is 1 / 5.0 (typ.).

Ex.: In case of 100% setting,

When $V_{ref} = 3.0 \text{ V}$, Torque = 100%, and $R_{RS} = 0.51 \Omega$,

constant current output of the motor (peak current) is calculated as follows;

$$I_{out} = 3.0 \text{ V} / 5.0 / 0.51 \Omega = 1.18 \text{ A.}$$

OSCM oscillation frequency

For OSCM oscillation frequency, you can change the frequency with an external capacitor and resistor.

By changing the frequency of the OSCM, it will be able to change the chopping frequency.

Please perform the adjustment of chopping frequency refer to the following table.

Chopping [kHz]	C [pF]	R [kΩ]
150	150	180
140	180	100
130	180	150
120	220	100
110	180	220
100	270	120
90	330	68
80	330	130
70	390	130
60	470	120
50	560	180
40	820	68

PD – Ta (Package Power Dissipation)

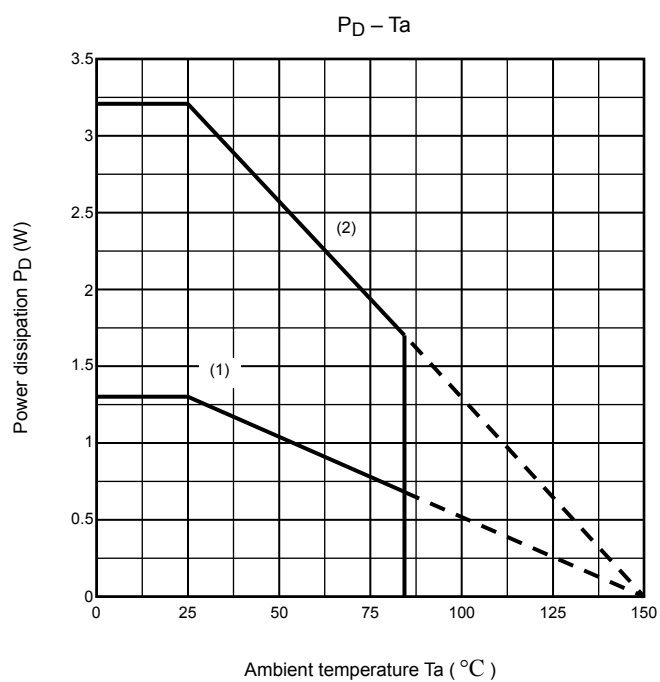

- (1) IC only: R_{th(j-a)}: 113°C/W
- (2) When mounted on the board (100 mm × 200 mm × 1.6 mm: 37°C/W (typ.))

Operating Time for Over-current Detection Circuit

ISD Dead Band Time and ISD Operating Time

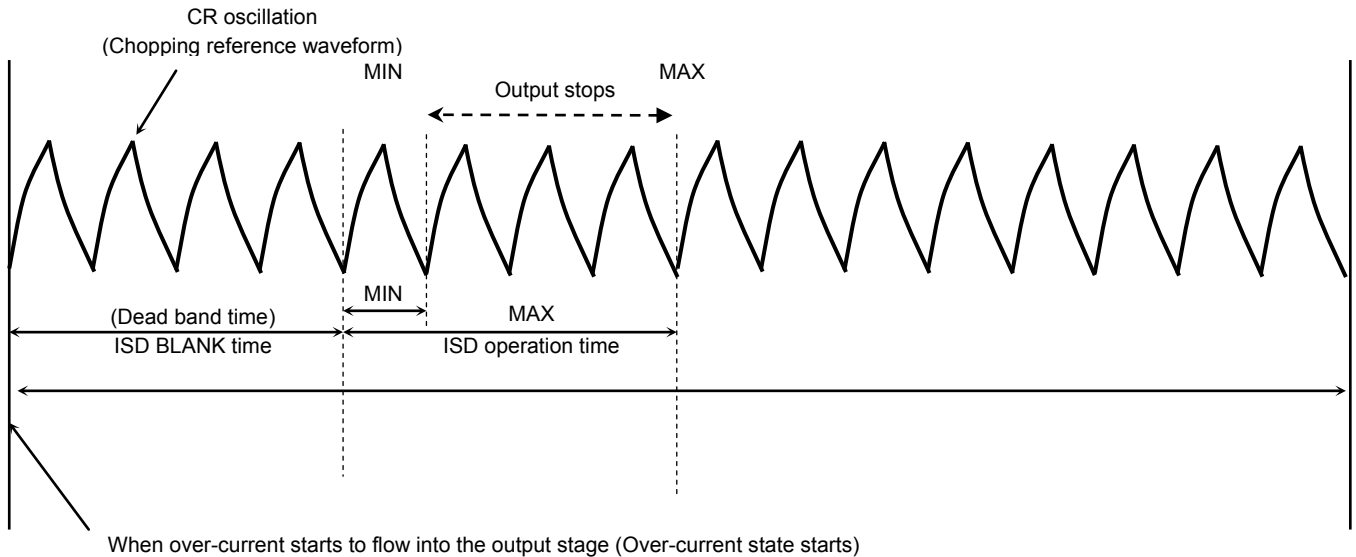

The over-current detection circuit has a dead band time to prevent erroneous detection of I_{RR} or spike current at switching. The dead band time being synchronized with the frequency of the OSC for setting chopping frequency is expressed as follows.

Dead band time = $4 \times$ CR time

Time required to stop the output after over-current flows into the output stage is expressed as follows.

Minimum time: $4 \times$ CR time

Maximum time: $8 \times$ CR time

Note that the above-mentioned operating times are achieved only when over-current flows as it is expected. Depending on the timing of output control mode, the circuit may not be triggered.

Thus, to ensure safe operation, please insert a fuse in the motor power supply.

The capacity of the fuse is determined according to the usage conditions. Please select one whose capacity does not exceed the power dissipation for the IC to avoid any operating problems.

• **tBLANK (noise rejection dead band time)**

The TC78S122FNG incorporates two different dead band times (blank times) for different motors to be driven so as to prevent malfunctions because of switching noise.

(1) Analog tBLANK Functions (in Stepping Motor Mode)

The noise rejection dead band time (analog tBLANK) defined by the AC characteristics of the motor block is fixed within the IC. It is mainly used to avoid misjudging the I_{RR} (diode recovery current) when a stepping motor is driven by constant current.

It is fixed within the IC and thus cannot be altered.

(2) Digital tBLANK (in Brushed DC Motor mode)

In addition to analog tBLANK, the digital tBLANK time is generated digitally from an external chopping period. This blank time is used to prevent false detections of over-current conditions due to recovery currents of a varistor generated during PWM operation of DC motors in DC Motor mode.

When stepping Motor mode is selected via the mode select pins, the digital tBLANK time is nullified ($0\ \mu\text{s}$) and the analog tBLANK time, which is internally fixed, becomes effective.

Since this blank time is generated based on the OSCM signal, the time can be adjusted by changing the OSCM signal frequency.

(Please note that the characteristics other than the blank time, such as motor chopping frequency and the dead band time inserted at power on, are also changed when the OSCM signal frequency is changed.)

Digital tBLANK Insertion Timing in Brushed DC Motor Mode

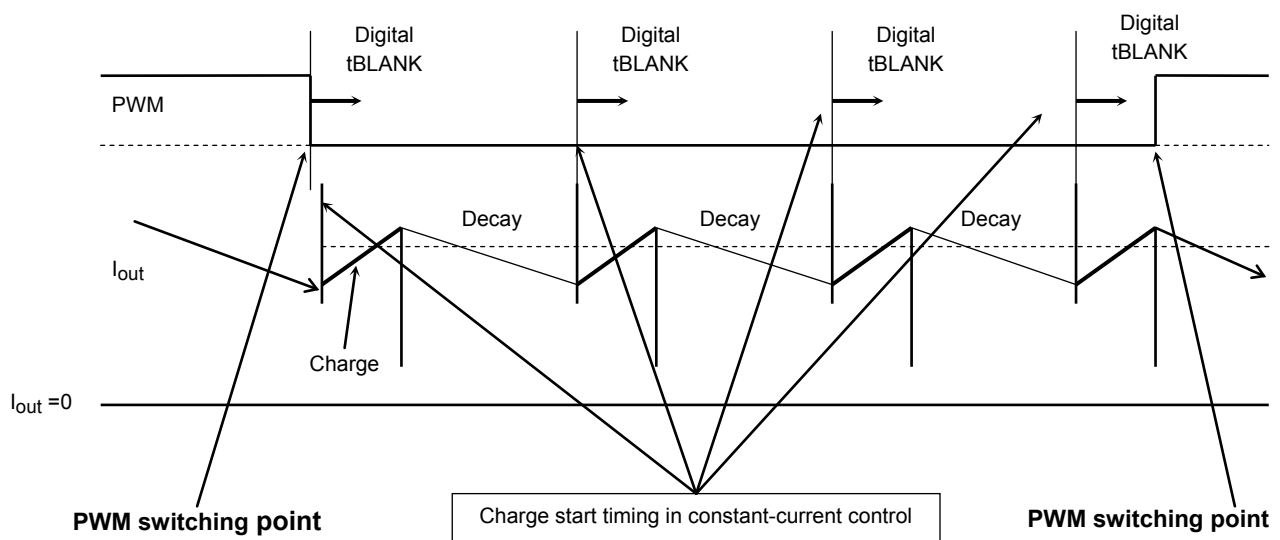

The digital tBLANK time is inserted immediately after the switching timing of externally applied PWM signals, CLK_X, ENABLE_X (such as the switching timing between short brake and charging), and also when the charging in constant-current chopper drive is started.

The digital tBLANK time becomes effective only in DC Motor mode.

The TC78S122FNG enters 37.5% Mixed-Decay mode when starting DC motor operation. In this mode, the TC78S122FNG stays in Charge mode for the first 4 CLK cycles of the whole period, which is also a digital tBLANK time. Thus, depending on the timing, operation mode might be switched directly to Fast-Decay mode.

Example Application Circuits

The values shown in the following figure are typical values. For input conditions, see the Operating Ranges.

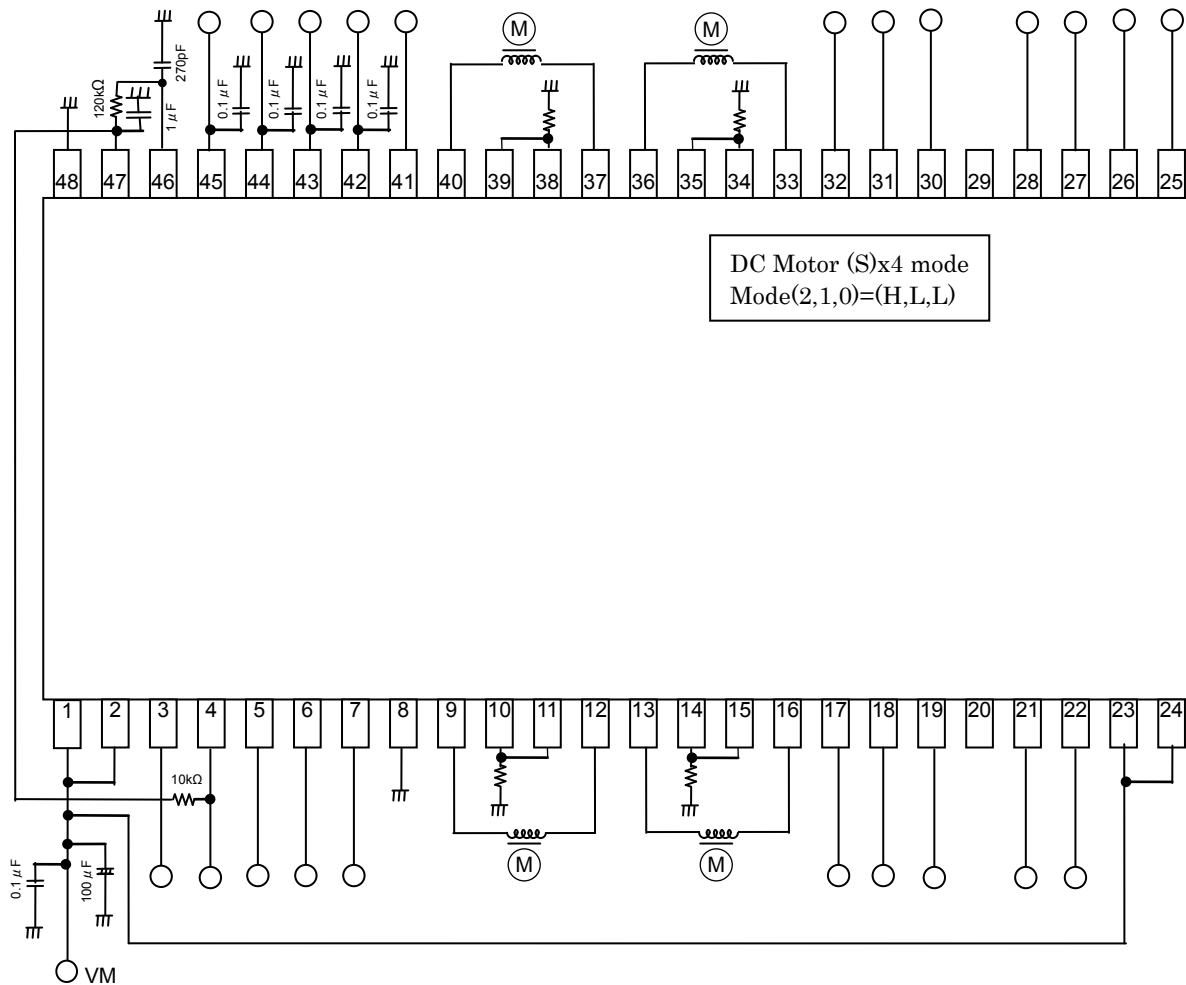

Note: It is recommended that a bypass capacitor is added if necessary. The GND wiring must become one-point-earth as much as possible.

The example of an applied circuit is for reference, and enough evaluation should be done before the mass-production design.

Moreover, it is not the one to permit the use of the industrial property.

Notes on Contents**(1) Block Diagrams**

Some of the functional blocks, circuits, or constants in the block diagram may be omitted or simplified for explanatory purposes.

(2) Equivalent Circuits

The equivalent circuit diagrams may be simplified or some parts of them may be omitted for explanatory purposes.

(3) Timing Charts

Timing charts may be simplified for explanatory purposes.

(4) Application Circuits

The application circuits shown in this document are provided for reference purposes only. Thorough evaluation is required, especially at the mass production design stage.

Toshiba does not grant any license to any industrial property rights by providing these examples of application circuits.

(5) Test Circuits

Components in the test circuits are used only to obtain and confirm the device characteristics. These components and circuits are not guaranteed to prevent malfunction or failure from occurring in the application equipment.

IC Usage Considerations**Notes on Handling of ICs**

- (1) The absolute maximum ratings of a semiconductor device are a set of ratings that must not be exceeded, even for a moment. Do not exceed any of these ratings.
Exceeding the rating(s) may cause the device breakdown, damage or deterioration, and may result injury by explosion or combustion
- (2) Do not insert devices in the wrong orientation or incorrectly.
Make sure that the positive and negative terminals of power supplies are connected properly.
Otherwise, the current or power consumption may exceed the absolute maximum rating, and exceeding the rating(s) may cause the device breakdown, damage or deterioration, and may result injury by explosion or combustion.
In addition, do not use any device that is applied the current with inserting in the wrong orientation or incorrectly even just one time.
- (3) Use an appropriate power supply fuse to ensure that a large current does not continuously flow in case of over-current and/or IC failure. The IC will fully break down when used under conditions that exceed its absolute maximum ratings, when the wiring is routed improperly or when an abnormal pulse noise occurs from the wiring or load, causing a large current to continuously flow and the breakdown can lead smoke or ignition. To minimize the effects of the flow of a large current in case of breakdown, appropriate settings, such as fuse capacity, fusing time and insertion circuit location, are required.
- (4) If your design includes an inductive load such as a motor coil, incorporate a protection circuit into the design to prevent device malfunction or breakdown caused by the current resulting from the inrush current at power ON or the negative current resulting from the back electromotive force at power OFF. IC breakdown may cause injury, smoke or ignition.
Use a stable power supply with ICs with built-in protection functions. If the power supply is unstable, the protection function may not operate, causing IC breakdown. IC breakdown may cause injury, smoke or ignition.

- (5) Carefully select external components (such as inputs and negative feedback capacitors) and load components (such as speakers), for example, power amp and regulator. If there is a large amount of leakage current such as input or negative feedback capacitor, the IC output DC voltage will increase. If this output voltage is connected to a speaker with low input withstand voltage, over-current or IC failure can cause smoke or ignition. (The over-current can cause smoke or ignition from the IC itself.) In particular, please pay attention when using a Bridge Tied Load (BTL) connection type IC that inputs output DC voltage to a speaker directly.

Points to Remember on Handling of ICs

- (1) **Over-current Protection Circuit**
Over-current protection circuits (referred to as current limiter circuits) do not necessarily protect ICs under all circumstances. If the Over-current protection circuits operate against the over-current, clear the over-current status immediately.
Depending on the method of use and usage conditions, such as exceeding absolute maximum ratings can cause the over-current protection circuit to not operate properly or IC breakdown before operation. In addition, depending on the method of use and usage conditions, if over-current continues to flow for a long time after operation, the IC may generate heat resulting in breakdown.
- (2) **Thermal Shutdown Circuit**
Thermal shutdown circuits do not necessarily protect ICs under all circumstances. If the thermal shutdown circuits operate against the over temperature, clear the heat generation status immediately.
Depending on the method of use and usage conditions, such as exceeding absolute maximum ratings can cause the thermal shutdown circuit to not operate properly or IC breakdown before operation.
- (3) **Heat Radiation Design**
In using an IC with large current flow such as power amp, regulator or driver, please design the device so that heat is appropriately radiated, not to exceed the specified junction temperature (T_j) at any time and condition. These ICs generate heat even during normal use. An inadequate IC heat radiation design can lead to decrease in IC life, deterioration of IC characteristics or IC breakdown. In addition, please design the device taking into consideration the effect of IC heat radiation with peripheral components.
- (4) **Back-EMF**
When a motor rotates in the reverse direction, stops or slows down abruptly, a current flow back to the motor's power supply due to the effect of back-EMF. If the current sink capability of the power supply is small, the device's motor power supply and output pins might be exposed to conditions beyond absolute maximum ratings. To avoid this problem, take the effect of back-EMF into consideration in system design.

RESTRICTIONS ON PRODUCT USE

- Toshiba Corporation, and its subsidiaries and affiliates (collectively "TOSHIBA"), reserve the right to make changes to the information in this document, and related hardware, software and systems (collectively "Product") without notice.
- This document and any information herein may not be reproduced without prior written permission from TOSHIBA. Even with TOSHIBA's written permission, reproduction is permissible only if reproduction is without alteration/omission.
- Though TOSHIBA works continually to improve Product's quality and reliability, Product can malfunction or fail. Customers are responsible for complying with safety standards and for providing adequate designs and safeguards for their hardware, software and systems which minimize risk and avoid situations in which a malfunction or failure of Product could cause loss of human life, bodily injury or damage to property, including data loss or corruption. Before customers use the Product, create designs including the Product, or incorporate the Product into their own applications, customers must also refer to and comply with (a) the latest versions of all relevant TOSHIBA information, including without limitation, this document, the specifications, the data sheets and application notes for Product and the precautions and conditions set forth in the "TOSHIBA Semiconductor Reliability Handbook" and (b) the instructions for the application with which the Product will be used with or for. Customers are solely responsible for all aspects of their own product design or applications, including but not limited to (a) determining the appropriateness of the use of this Product in such design or applications; (b) evaluating and determining the applicability of any information contained in this document, or in charts, diagrams, programs, algorithms, sample application circuits, or any other referenced documents; and (c) validating all operating parameters for such designs and applications. **TOSHIBA ASSUMES NO LIABILITY FOR CUSTOMERS' PRODUCT DESIGN OR APPLICATIONS.**
- **PRODUCT IS NEITHER INTENDED NOR WARRANTED FOR USE IN EQUIPMENTS OR SYSTEMS THAT REQUIRE EXTRAORDINARILY HIGH LEVELS OF QUALITY AND/OR RELIABILITY, AND/OR A MALFUNCTION OR FAILURE OF WHICH MAY CAUSE LOSS OF HUMAN LIFE, BODILY INJURY, SERIOUS PROPERTY DAMAGE AND/OR SERIOUS PUBLIC IMPACT ("UNINTENDED USE").** Except for specific applications as expressly stated in this document, Unintended Use includes, without limitation, equipment used in nuclear facilities, equipment used in the aerospace industry, medical equipment, equipment used for automobiles, trains, ships and other transportation, traffic signaling equipment, equipment used to control combustions or explosions, safety devices, elevators and escalators, devices related to electric power, and equipment used in finance-related fields. **IF YOU USE PRODUCT FOR UNINTENDED USE, TOSHIBA ASSUMES NO LIABILITY FOR PRODUCT.** For details, please contact your TOSHIBA sales representative.
- Do not disassemble, analyze, reverse-engineer, alter, modify, translate or copy Product, whether in whole or in part.
- Product shall not be used for or incorporated into any products or systems whose manufacture, use, or sale is prohibited under any applicable laws or regulations.
- The information contained herein is presented only as guidance for Product use. No responsibility is assumed by TOSHIBA for any infringement of patents or any other intellectual property rights of third parties that may result from the use of Product. No license to any intellectual property right is granted by this document, whether express or implied, by estoppel or otherwise.
- **ABSENT A WRITTEN SIGNED AGREEMENT, EXCEPT AS PROVIDED IN THE RELEVANT TERMS AND CONDITIONS OF SALE FOR PRODUCT, AND TO THE MAXIMUM EXTENT ALLOWABLE BY LAW, TOSHIBA (1) ASSUMES NO LIABILITY WHATSOEVER, INCLUDING WITHOUT LIMITATION, INDIRECT, CONSEQUENTIAL, SPECIAL, OR INCIDENTAL DAMAGES OR LOSS, INCLUDING WITHOUT LIMITATION, LOSS OF PROFITS, LOSS OF OPPORTUNITIES, BUSINESS INTERRUPTION AND LOSS OF DATA, AND (2) DISCLAIMS ANY AND ALL EXPRESS OR IMPLIED WARRANTIES AND CONDITIONS RELATED TO SALE, USE OF PRODUCT, OR INFORMATION, INCLUDING WARRANTIES OR CONDITIONS OF MERCHANTABILITY, FITNESS FOR A PARTICULAR PURPOSE, ACCURACY OF INFORMATION, OR NONINFRINGEMENT.**
- Do not use or otherwise make available Product or related software or technology for any military purposes, including without limitation, for the design, development, use, stockpiling or manufacturing of nuclear, chemical, or biological weapons or missile technology products (mass destruction weapons). Product and related software and technology may be controlled under the applicable export laws and regulations including, without limitation, the Japanese Foreign Exchange and Foreign Trade Law and the U.S. Export Administration Regulations. Export and re-export of Product or related software or technology are strictly prohibited except in compliance with all applicable export laws and regulations.
- Please contact your TOSHIBA sales representative for details as to environmental matters such as the RoHS compatibility of Product. Please use Product in compliance with all applicable laws and regulations that regulate the inclusion or use of controlled substances, including without limitation, the EU RoHS Directive. **TOSHIBA ASSUMES NO LIABILITY FOR DAMAGES OR LOSSES OCCURRING AS A RESULT OF NONCOMPLIANCE WITH APPLICABLE LAWS AND REGULATIONS.**