

DO NOT SCALE FROM THIS PRINT

FIG 1
(IPL1-110-02-XXX-SH-K SHOWN)

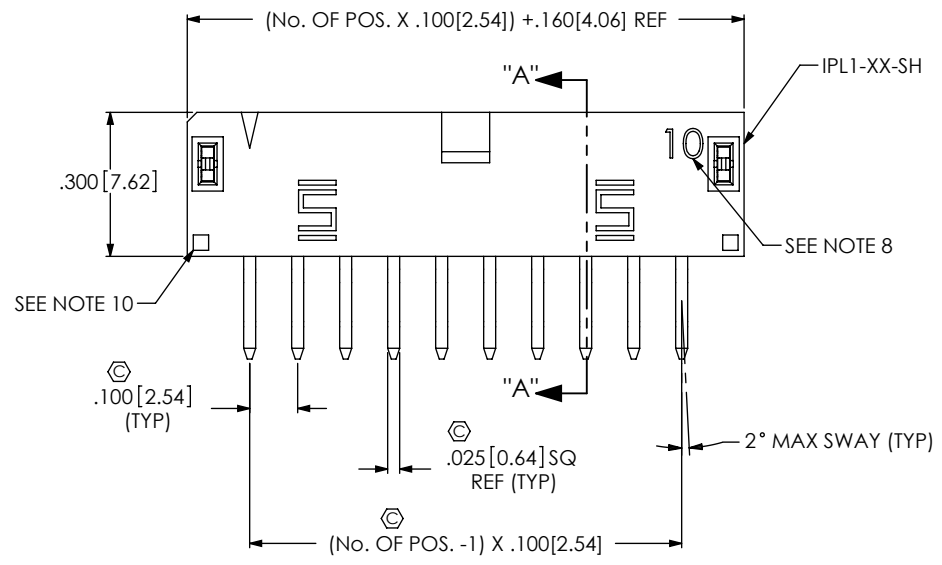
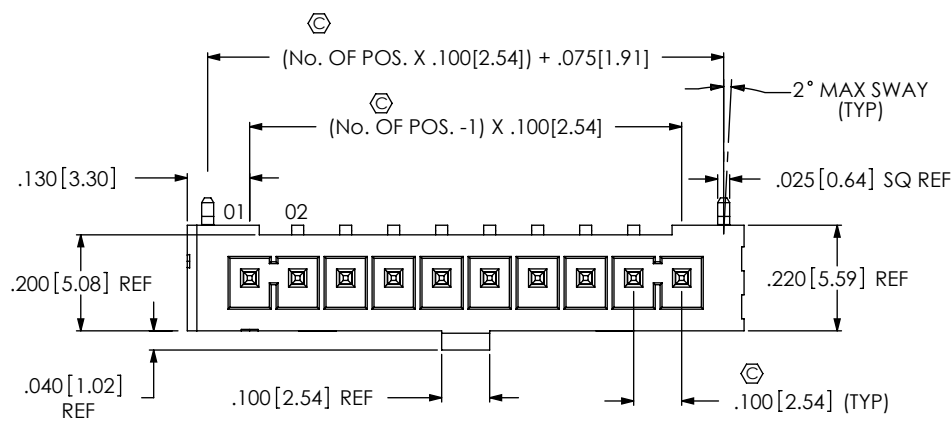

IPL1-1XX-XX-XXX-SH-K-XX

- No OF POSITIONS: -02 THRU -25
- LEAD STYLE:
 - 02: SINGLE HORIZONTAL .062 BOARD (USE T-1S64-09-XXX)
 - 03: SINGLE HORIZONTAL .093 BOARD (USE T-1S64-09-XXX)
- PLATING SPECIFICATION:
 - F: FLASH SELECTIVE (USE T-1S64-09-F)
 - L: LIGHT SELECTIVE (USE T-1S64-09-L)
 - S: SELECTIVE (USE T-1S64-09-S)
 - STL: SELECTIVE TIN/LEAD (USE T-1S64-09-STL)
- OPTION:
 - TR: TAPE & REEL (SEE NOTE 9)
 - POLARIZATION:
 - K: KEYED POLARIZATION
 - ROW SPECIFICATION:
 - SH: SINGLE HORIZONTAL

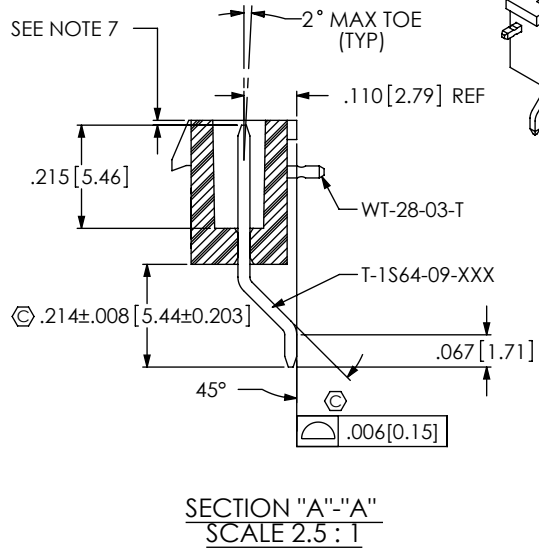
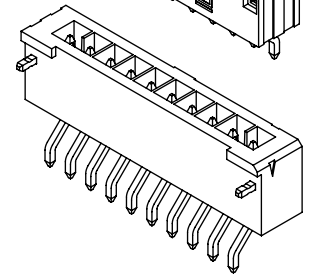
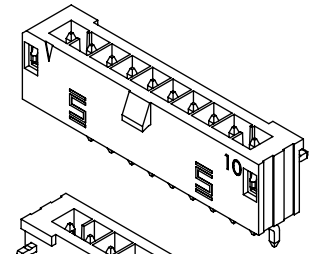

- NOTES:
1. \varnothing REPRESENTS A CRITICAL DIMENSION.
 2. MINIMUM TERMINAL / WELD TAB RETENTION: 1.0LB. [4.4N]
 3. PARTS TO BE MOLDED TO POSITION.
 4. POST MUST BE WITHIN .005[0.13] OF EACH OTHER.
 5. ALL PIN TO PIN DIMENSIONS TO BE MEASURED FROM TIP TO TIP.
 6. DIMENSION TO BE MEASURED AT BEND.
 7. TIP TO BE FLUSH TO .010[0.254] BELOW TOP OF SHROUD.
 8. THIS NUMBER REPRESENTS THE NUMBER OF POSITIONS PER ROW ONLY AND IS NOT INTENDED TO BE USED IN POSITION NUMBERING.
 9. PARTS TO BE PACKAGED IN TUBES IF TAPE & REEL IS NOT SPECIFIED.
 10. INDENTION FROM WELD TAB CARRIER IS ALLOWABLE.

UNLESS OTHERWISE SPECIFIED, DIMENSIONS ARE IN INCHES. TOLERANCES ARE:
 DECIMALS ANGLES
 .XX: $\pm .01$ [.3] 2°
 .XXX: $\pm .005$ [.13]
 .XXXX: $\pm .0020$ [.051]

PROPRIETARY NOTE
 THIS DOCUMENT CONTAINS INFORMATION CONFIDENTIAL AND PROPRIETARY TO SAMTEC, INC. AND SHALL NOT BE REPRODUCED OR TRANSFERRED TO OTHER DOCUMENTS OR DISCLOSED TO OTHERS OR USED FOR ANY PURPOSE OTHER THAN THAT WHICH IT WAS OBTAINED WITHOUT THE EXPRESSED WRITTEN CONSENT OF SAMTEC, INC.



520 PARK EAST BLVD., NEW ALBANY, IN 47150
 PHONE: 812-944-6733 FAX: 812-948-5047
 e-Mail: info@SAMTEC.com code 55322

MATERIAL: DO NOT SCALE DRAWING SHEET SCALE: 2:1
 INSULATOR: LCP UL94-V0, COLOR: BLACK
 TERMINAL: PHOS BRONZE

DESCRIPTION: .100[2.54] SINGLE ROW TERMINAL ASSEMBLY
 DWG. NO. IPL1-1XX-XX-XXX-SH-K-XX

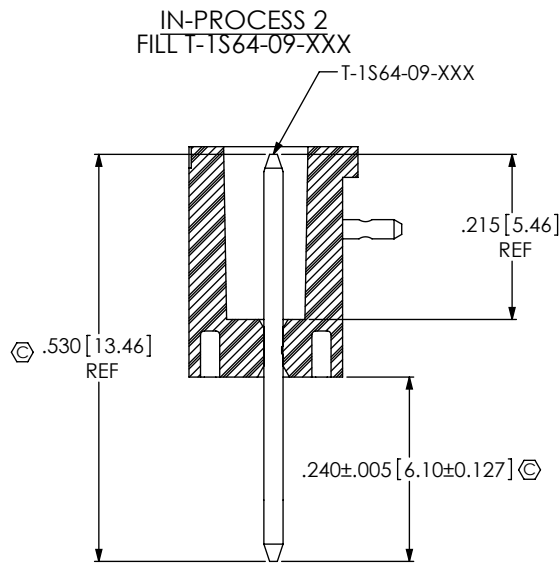
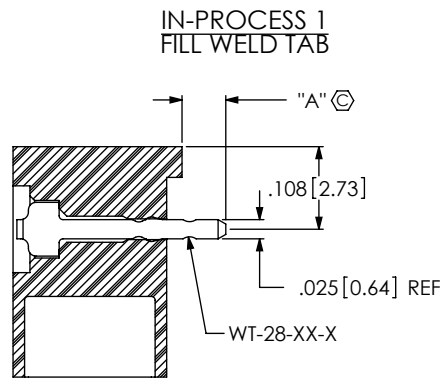

PACKAGING VIEW
(PARTS TO HAVE POSITION #T LOADED
IN SAME DIRECTION AS ARROW ON TUBE)

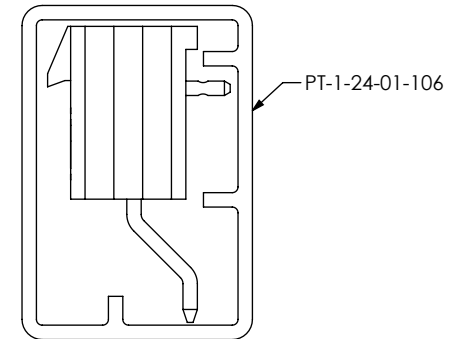

PACKAGING TABLE		
LEAD STYLE	PACKAGING TUBE	PLUG
-02	PT-1-24-01-106	TP-07
-03	PT-1-24-01-106	TP-07

TABLE 1		
LEAD STYLE	"A"	WELD TAB
-02	.055	WT-28-03-X
-03	.086	WT-28-04-X

FIG. 2
(IPL1-125-02-XXX-SH-K SHOWN)
(DIFFERENT AS SHOWN, OTHERWISE SAME AS FIG. 1)

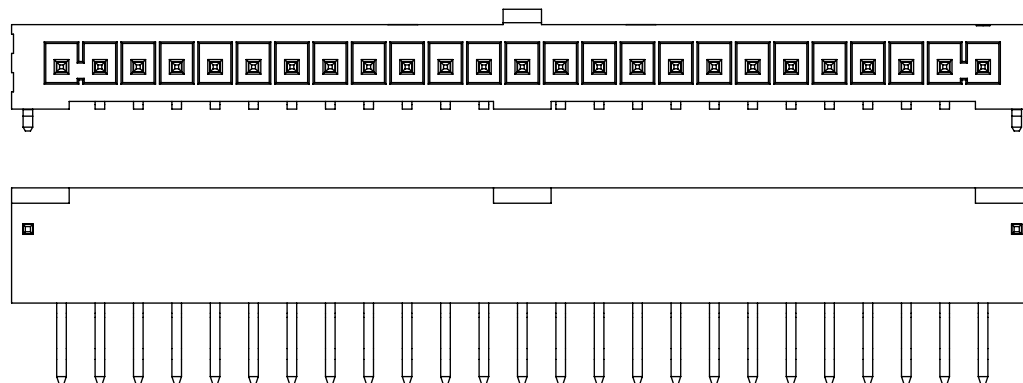

F:\DWG\MISC\MKTG\IPL1-1XX-XX-XXX-SH-K-XX-MKT.SLDRW

PROPRIETARY NOTE
THIS DOCUMENT CONTAINS INFORMATION
CONFIDENTIAL AND PROPRIETARY TO
SAMTEC, INC. AND SHALL NOT BE REPRODUCED
OR TRANSFERRED TO OTHER DOCUMENTS OR
DISCLOSED TO OTHERS OR USED FOR ANY
PURPOSE OTHER THAN THAT WHICH IT WAS
OBTAINED WITHOUT THE EXPRESSED WRITTEN
CONSENT OF SAMTEC, INC.

DO NOT SCALE DRAWING

SHEET SCALE: 2:1

samtec

520 PARK EAST BLVD, NEW ALBANY, IN 47150
PHONE: 812-944-6733 FAX: 812-948-5047
e-Mail info@SAMTEC.com code 55322

DESCRIPTION:
.100 [2.54] SINGLE ROW TERMINAL ASSEMBLY

DWG. NO.
IPL1-1XX-XX-XXX-SH-K-XX

BY: D. SCHMELZ 10/31/2008 SHEET 2 OF 2