

CAD GENERATED DRAWING - NO PENCIL CHANGES ALLOWED

% OF RATED CURRENT	OPENING TIME	
	MIN	MAX
110%	14,400 SEC.	-
200%	5 SEC.	100 SEC.
350%	0.2 SEC.	7 SEC.
600%	0.04 SEC.	1 SEC.

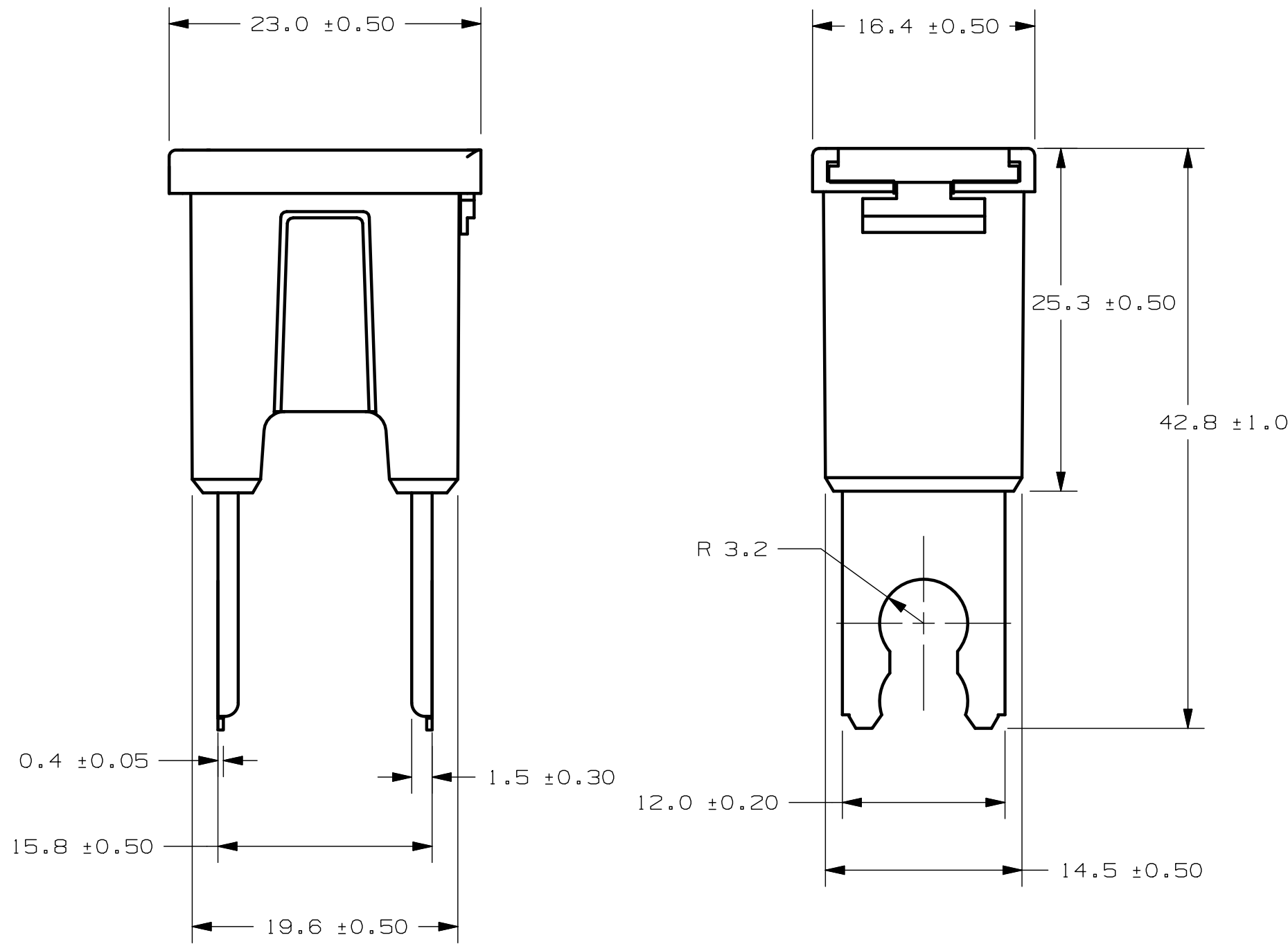
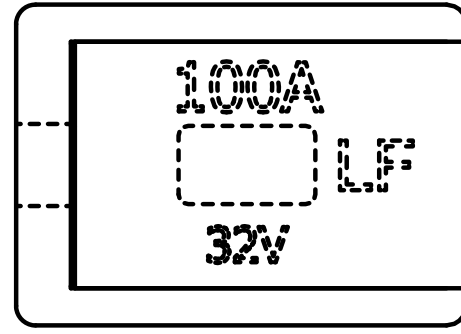

PART NUMBER	CURRENT RATING (A)	BODY COLOR
0294030.MXJ	30	PINK
0294040.MXJ	40	GREEN
0294050.MXJ	50	RED
0294060.MXJ	60	YELLOW
0294070.MXJ	70	BROWN
0294080.MXJ	80	BLACK
0294100.MXJ	100	BLUE
0294120.MXJ	120	WHITE

UNLESS OTHERWISE SPECIFIED, DIMENSIONS ARE IN MILLIMETERS. DIMENSIONS IN BRACKETS [] ARE INCHES
UNLESS OTHERWISE SPECIFIED, DIMENSIONS DO NOT INCLUDE PLATING.
⊙ DENOTES CRITICAL CHARACTERISTICS.
CPK DENOTES CPK DIMENSIONS, -MINIMUM CPK VALUE
ST DENOTES A CHARACTERISTIC THAT PROVIDES AN INDICATION OF PROCESS PERFORMANCE. PROCEDURE FOR MEASUREMENT AND TRACKING TO BE DEFINED IN LITTELFUSE INSPECTION INSTRUCTIONS
CP DENOTES CP DIMENSIONS, -MINIMUM CP VALUE MUST BE WITHIN THE DIMENSIONAL LIMITATIONS SHOWN ON DRAWING AND INITIALLY LOCATED TO ALLOW FOR MAXIMUM TOOL LIFE

NO	COMPONENT NO	DESCRIPTION	QTY/M	U/M
BILL OF MATERIAL				

LTR	DATE	REVISION	CHK	APD
A	08/14/09	000762ER-RELEASE GMB		

COPIES TO	MATL SPEC
1 9 18	FINISH
2 10 19	DRW
3 12 20	DATE 08/14/09
4 13 21	GMB
5 14 23	CHK
6 15 33	DATE
7 16 43	APPD
8 17 53	DATE
	FINISH GOOD WT GRAMS/PIECE

ONE PLACE DEC +/- .4	TOLERANCE UNLESS OTHERWISE SPECIFIED
TWO PLACE DEC +/- .25	THREE PLACE DEC +/- .100
	ANGULAR +/- 1°

3RD ANGLE PROJECTION	TITLE	BOLT DOWN HIGH CURRENT CARTRIDGE FUSE
	REVISION	DRWG. NO.
	A	OL-0294000.MXJ
		OUTLINE

Littelfuse	
DES PLAINES, ILLINOIS 60016	

METRIC