

4

3

2

1

THIS DRAWING IS UNPUBLISHED. RELEASED FOR PUBLICATION, 19 .  
 © COPYRIGHT 19 BY AMP INCORPORATED. ALL RIGHTS RESERVED.

LOC	DIST	REVISIONS			
P	LTR	DESCRIPTION	DATE	DWN	APVD
AF	50	E	REDRAWN PER 0G1A-0029-98	2/18/98	JR JW

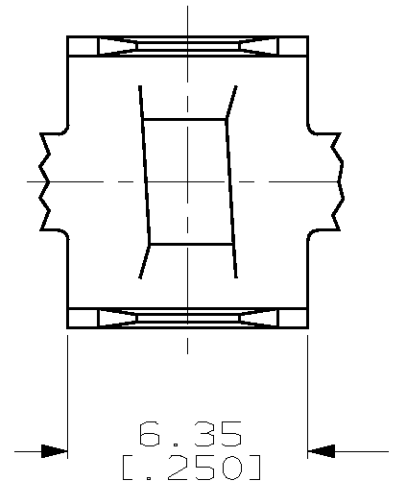

1 CONTINUOUS STRIP ON REELS.  
 2 0.00381 [0.000150] MIN PRE-TIN OVER  
 0.00254 [0.000100] MIN COPPER.

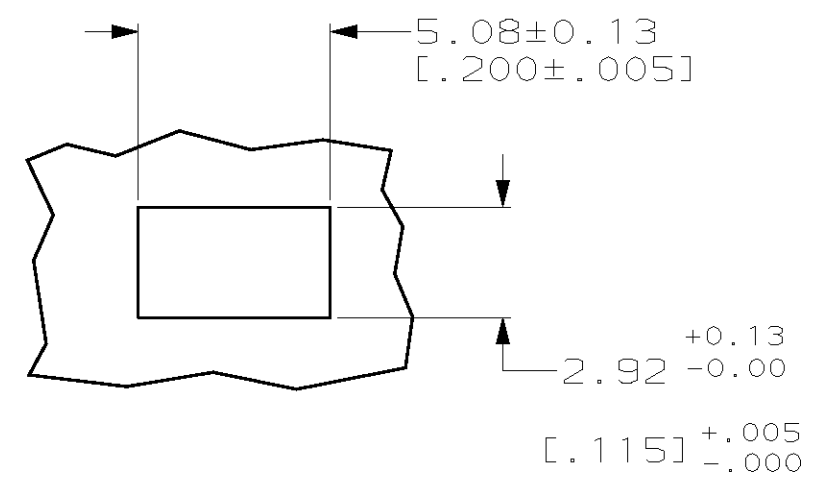
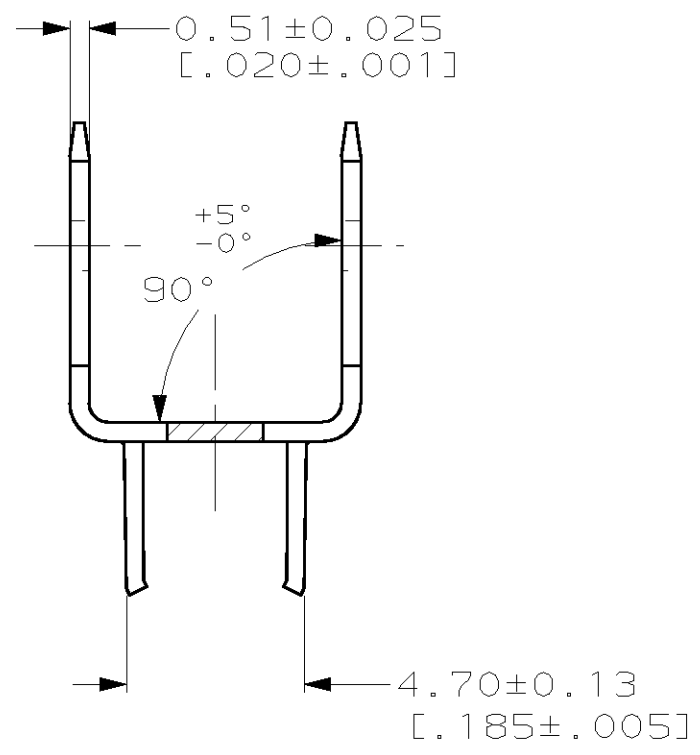
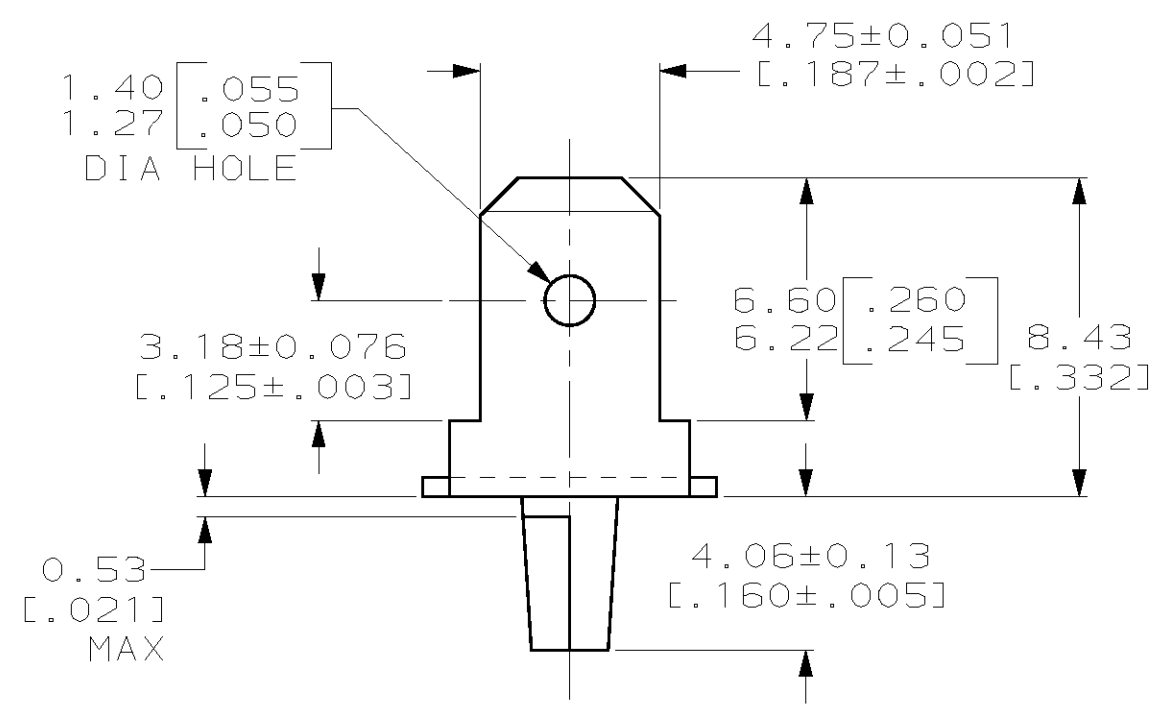

HOLE SIZE  
 FOR 1.57 [0.062]  
 THICK BOARD

63224-1  
 PART NO.

THIS DRAWING IS A CONTROLLED DOCUMENT.		DWN JR RUTH 2/18/98	<b>AMP</b> AMP Incorporated Harrisburg, PA 17105-3608
DIMENSIONS: MM [INCHES]		CHK MS FEHER 2/18/98	
TOLERANCES UNLESS OTHERWISE SPECIFIED:		APVD J WORMAN 2/18/98	NAME TAB, DUAL, FASTON, 4.75 [0.187] SERIES
0 PLC ±- 1 PLC ±- 2 PLC ±0.25 [0.010] 3 PLC ±- 4 PLC ±- ANGLES ±-		PRODUCT SPEC -	SIZE A3
MATERIAL #1 HARD BRASS		FINISH 2	CAGE CODE 00779
		WEIGHT -	DRAWING NO C-63224
		CUSTOMER DRAWING	SCALE 5:1
			SHEET 1 OF 1
			REV E